

Imprinting

10-12-2020

julie.martone@uniroma1.it

Genomic imprinting

The term **epigenetic** is used to refer to mechanisms that **do not involve changes in the DNA sequence** and that are heritable from one cell generation to the next.

Unlike heritable changes due to mutation or directed gene rearrangement, **epigenetic modifications are reversible** and can be removed from genes and chromosomes without leaving behind any permanent change to the genetic material.

We consider a particular class of **epigenetic imprints**, those that mark the parental origin of genomes, chromosomes, and genes. **Genes regulated by such “genomic imprinting” are expressed depending on whether they are on the maternally or on the paternally derived chromosome.** Some imprinted genes are expressed only from the paternal chromosome, whereas others are exclusively expressed from the maternal chromosome.

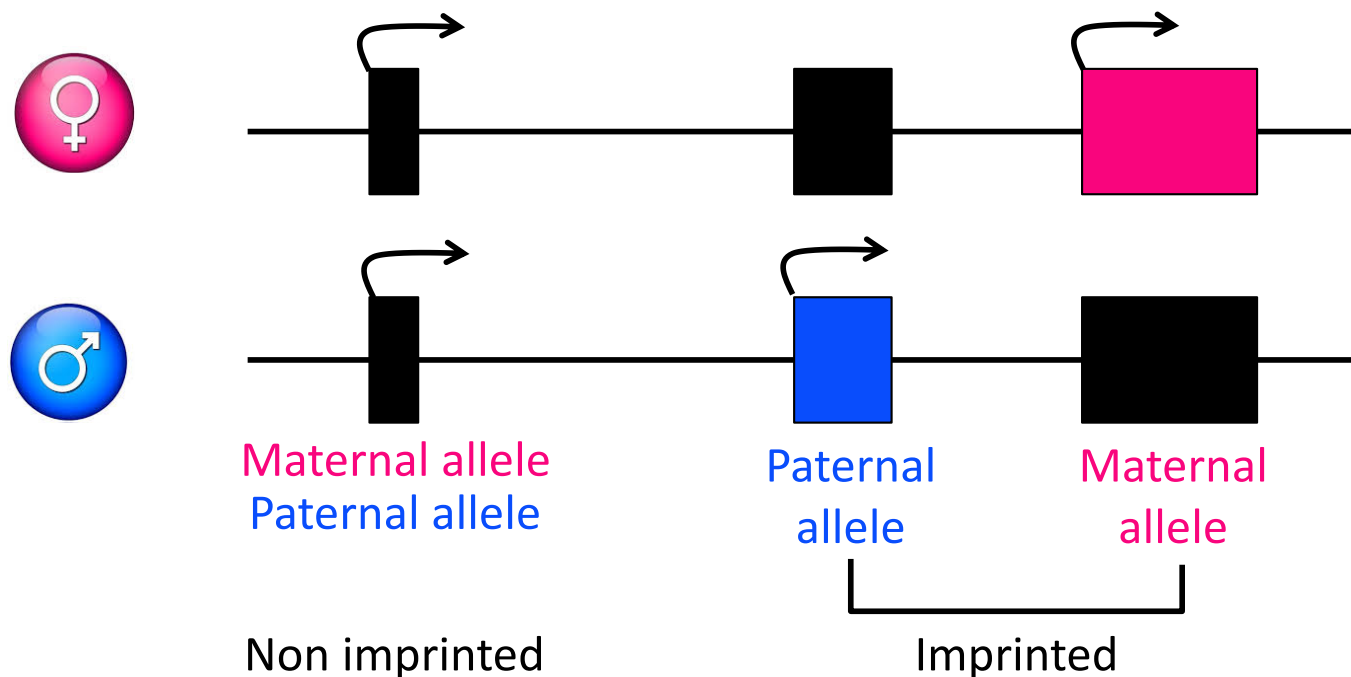

The unequal expression of the maternal and paternal alleles of a gene

Epigenetic regulation of normal cellular processes is typically driven in a cell type-dependent manner, requiring a complex interplay between different layers of epigenetic information, including **DNA methylation**, **nucleosome positions**, **histone modifications**, and **expression of noncoding RNA**. Several epigenetic mechanisms help establish and consolidate the correct higher-order chromatin structures and gene-expression patterns during differentiation and development. Of these, **DNA methylation** is the best-studied epigenetic modification in mammals. Precise DNA methylation patterns are established during embryonic development and are mitotically inherited through multiple cellular divisions. DNA methylation is necessary for normal cell development, underpinning X chromosome inactivation, control of some tissue-specific gene expression, and **regulation of imprinted alleles**, with widespread effects on cellular growth and genomic stability.

Epigenetic mechanisms that govern the role of epigenetics in gene expression without changing the underlying DNA sequence; include chromatin structure, histone modifications, nucleosome positioning, and DNA methylation.



DNA methylation

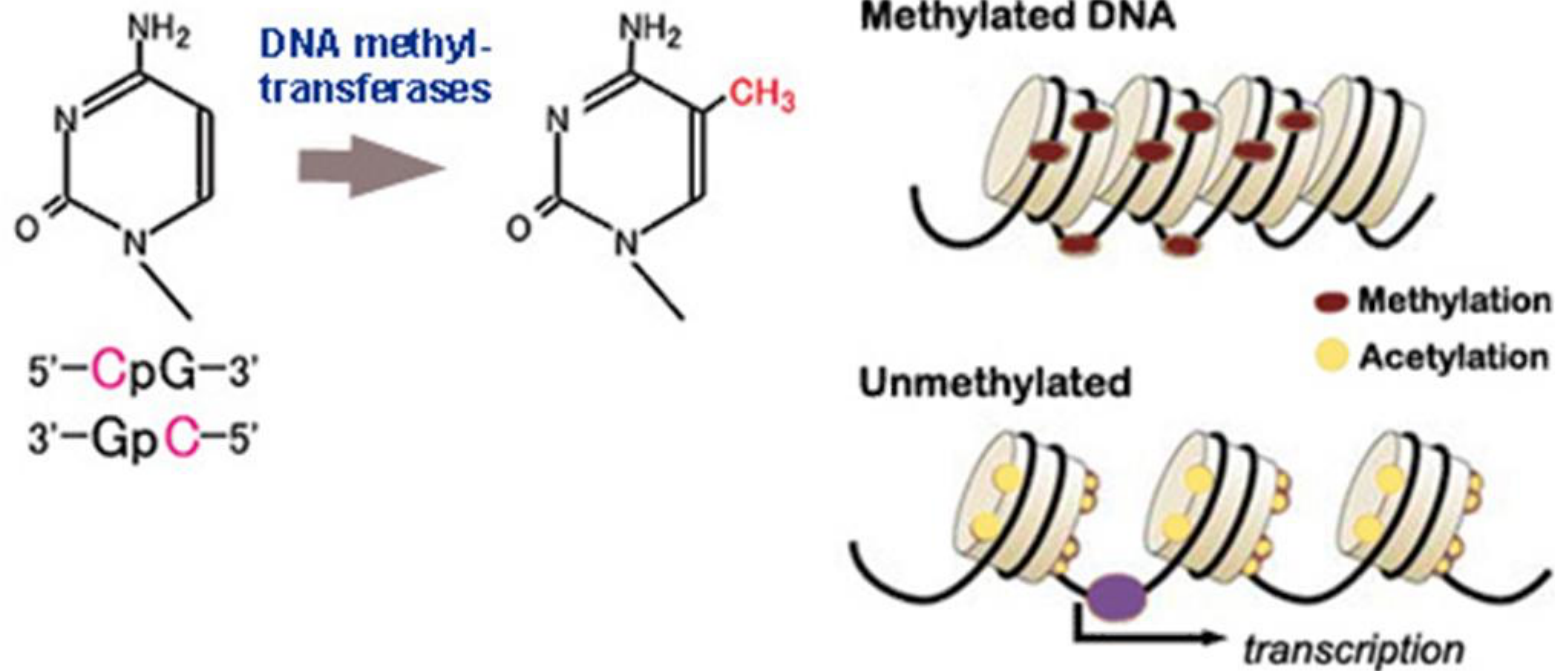

The best studied epigenetic modification is **DNA methylation**. In the genomes of mammals, this **covalent modification** occurs at many of the cytosine residues that are followed by a guanine residue. In most cases, the acquisition and somatic maintenance of such 'CpG methylation' induces **gene repression**. However, there are also examples where DNA methylation at specific sequence elements permits the expression of neighbouring genes

Histone modifications

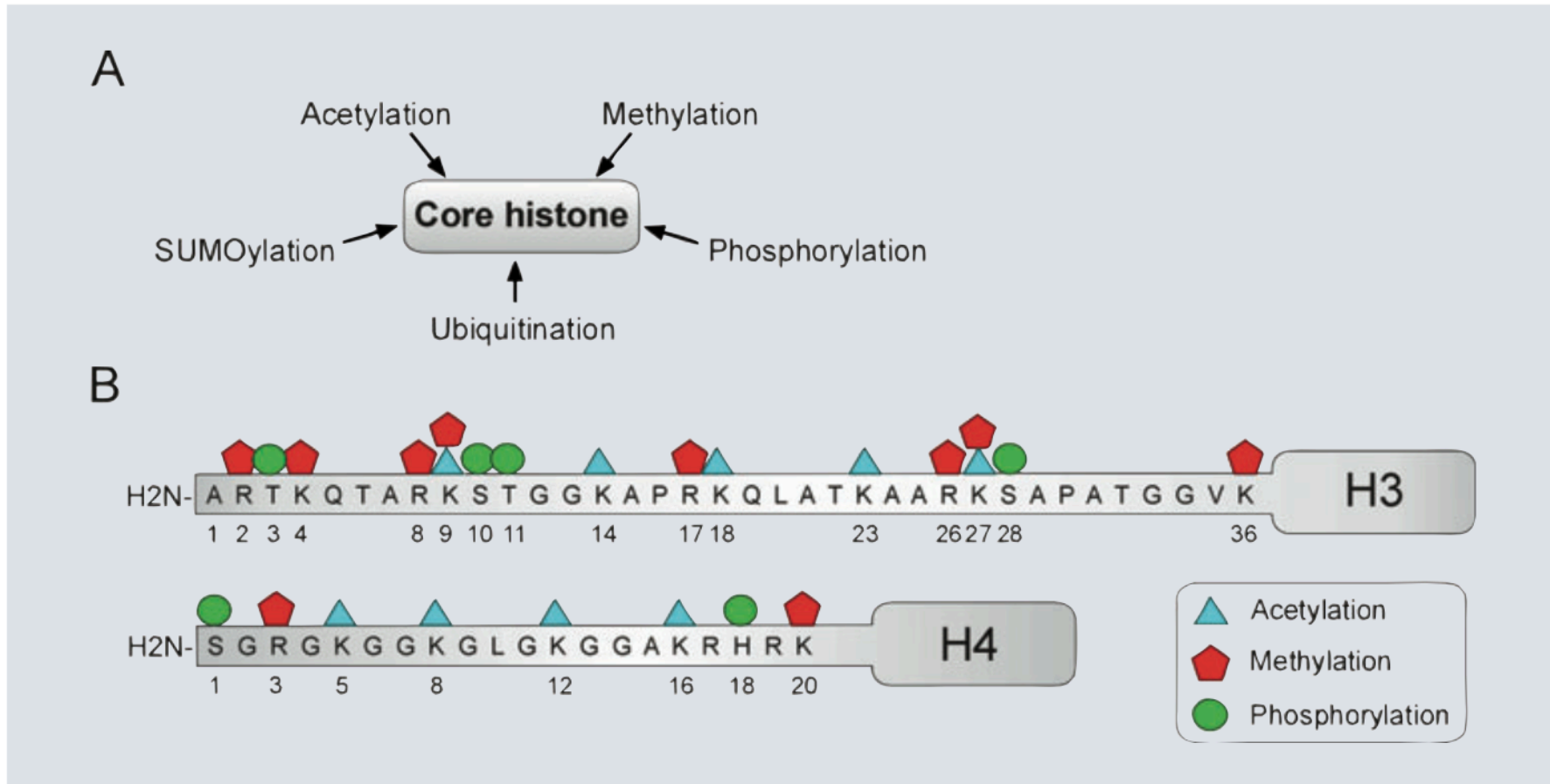

Fig. 2 Post-translational histone modifications. **(A)** Core histones can be methylated, acetylated, phosphorylated, ubiquitinated or SUMOylated, to modulate gene expression. **(B)** Known modifications on the amino-terminal tails of core histones H3 and H4.

Histone modifications

Type of modification	Histone							
	H3K4	H3K9	H3K14	H3K27	H3K79	H3K122	H4K20	H2BK5
mono-methylation	activation ^[6]	activation ^[7]		activation ^[7]	activation ^{[7][8]}		activation ^[7]	activation ^[7]
di-methylation	activation	repression ^[3]		repression ^[3]	activation ^[8]			
tri-methylation	activation ^[9]	repression ^[7]		repression ^[7]	activation, ^[8] repression ^[7]			repression ^[3]
acetylation		activation ^[9]	activation ^[9]	activation ^[10]		activation ^[11]		

- H3K4me3 is enriched in transcriptionally active promoters.^[12]
- H3K9me3 is found in constitutively repressed genes.
- H3K27me is found in facultatively repressed genes.^[7]
- H3K36me3 is found in actively transcribed gene bodies.
- H3K9ac is found in actively transcribed promoters.
- H3K14ac is found in actively transcribed promoters.
- H3K27ac distinguishes active enhancers from poised enhancers.
- H3K122ac is enriched in poised promoters and also found in a different type of putative enhancer that lacks H3K27ac.

Genomic Imprinting

- Nonequivalence in expression of alleles at certain gene loci dependent on the parent of origin.
- Only one parental allele is expressed.
- The current number of imprinted genes in the mouse is approximately 150 (<http://www.mousebook.org/catalog.php?catalog=imprinting>).
- The imprinted genes are typically located in clusters of 3-12 (or more) genes (1-2Mb) that play essential roles in the growth and development of the fetus, as well as in post-natal behavior and metabolism.

Genomic Imprinting

- Most imprinted clusters contain protein coding genes and noncoding RNAs (ncRNAs). The ncRNAs are of different varieties (microRNAs, snoRNAs, and lncRNAs), some of which are essential to the mechanism that imprints these genes in cis.
- These clusters typically contain genes that are expressed exclusively from the maternally or paternally inherited chromosomes
- While many imprinted genes are ubiquitously imprinted, some exhibit tissue-specific or temporal-specific imprinting patterns.
- Each well-studied cluster has a discrete imprinting control region (ICR) that exhibits parent-of-origin-specific epigenetic modifications (DNA methylation and post-translational histone modifications) and governs the imprinting of the locus. Although the mechanism(s) that confer the allele-specific epigenetic modifications is poorly understood.

- The acquisition of methylation at ICRs occurs in the germ line de novo by DNMT3A and DNMT3L with a small number of ICRs becoming methylated in sperm cells, and the majority acquiring methylation in oocytes—paternal and maternal ICRs, respectively. It is of interest that paternal ICRs are always located in intergenic regions while maternal ICRs are located at promoter sequences.
- In addition to the ICR, other differentially methylated regions (DMRs) are located at some imprinted clusters, but a notable difference between ICRs and these **DMRs** is that differential **methylation** of the latter is not germline established, but rather is acquired **post-fertilization**. In all cases, these so-called secondary **DMRs**—to distinguish them from regions such as ICRs that acquire differential methylation in the germline—**require the ICR for their establishment**.
- The **mechanisms through which ICRs control gene expression** in their respective clusters are diverse and remain the subject of active research, including analysis of regulation by ncRNAs and of the relationships between DNA methylation and histone and non-histone proteins.
- Little is known about why certain DNA sequences become methylated
- Acquisition of methylation represents the “active” process in establishing differential methylation

- In the germline, far more sequences are differentially methylated between oocytes and sperm than the ICRs; recent genome-wide studies suggest they are in the counts of thousands in oocytes and hundreds in sperm. In contrast to ICRs these sequences generally lose methylation after fertilization, suggesting **targeted maintenance** of DNA methylation at specific sequences is essential for the germline-derived differential methylation of imprinted loci.
- ZFP57, zinc finger proteins, has been shown to be required to maintain the DNA methylation memory at imprints during post-fertilization reprogramming when the bulk of the genome is changing its epigenetic state. ZFP57 binds methylated DNA and is thought to recruit methyltransferases to imprinting control regions hence preventing them from loss of their imprints.

Most Imprinted Genes are Found in Clusters and Regulated by Imprinting Control Regions

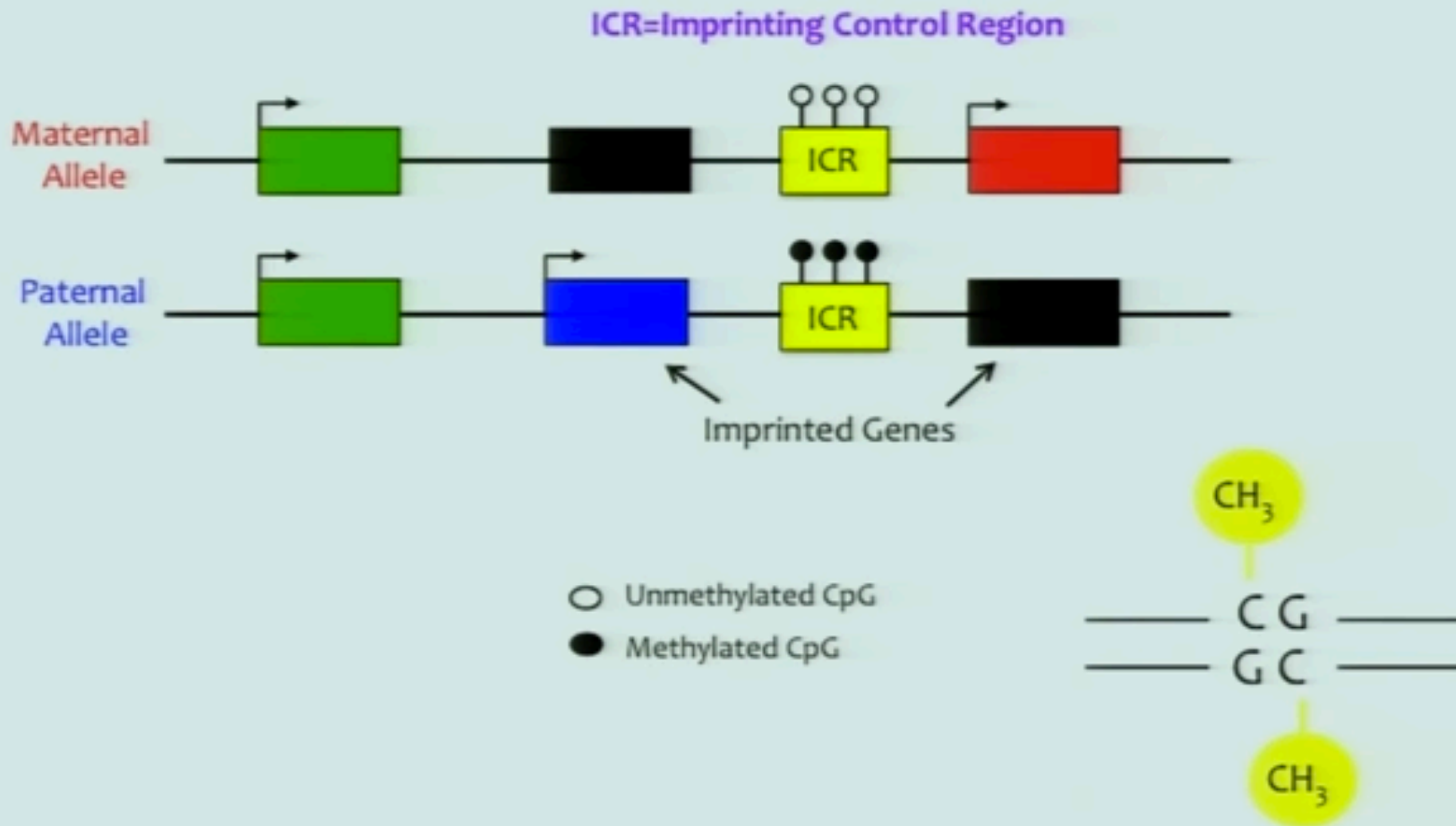

The imprinted allele is turned off, the DNA is methylated

DNA methylation changes during developmental epigenetic reprogramming.

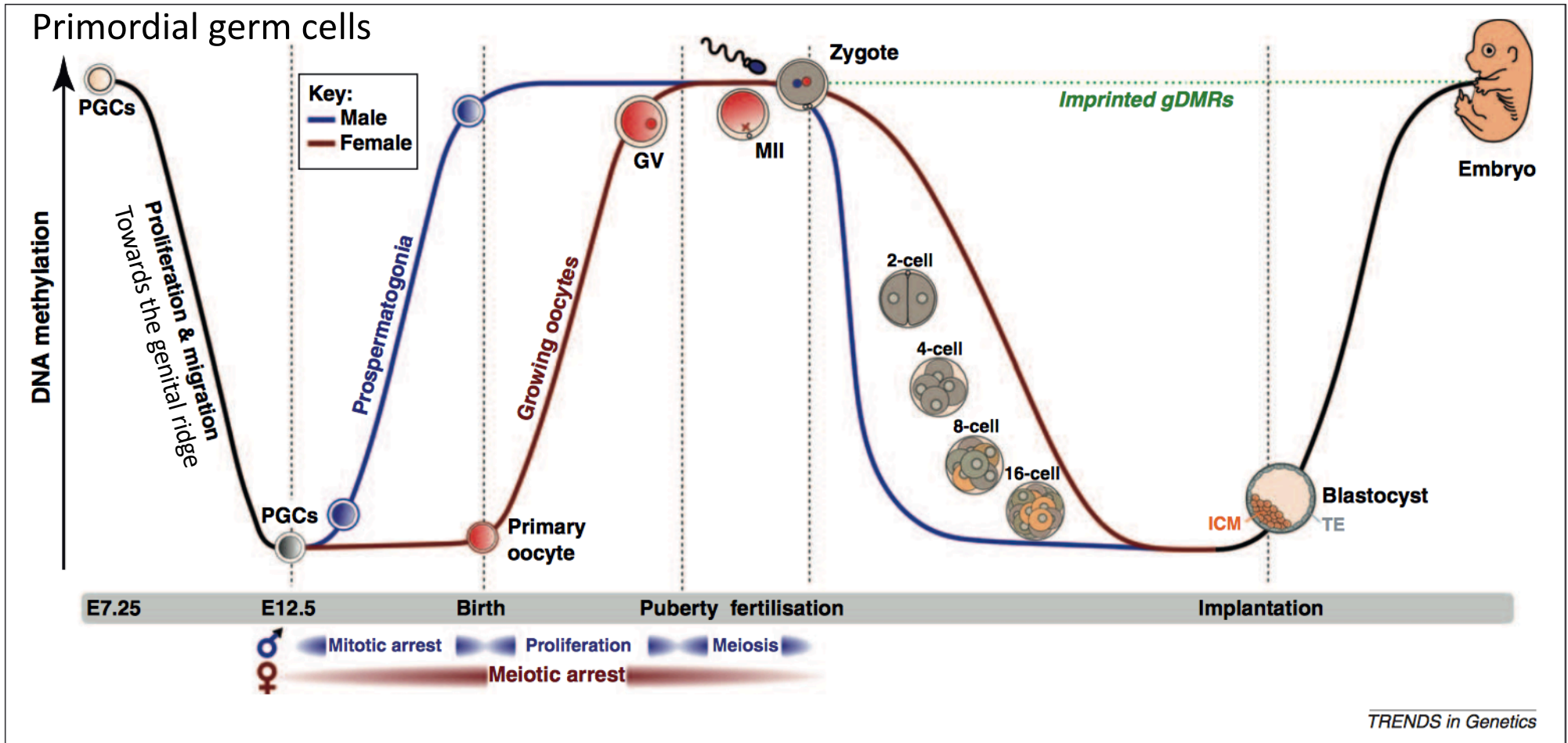

Following fertilisation, a new wave of DNA demethylation takes place that is distinct on the parental genomes.

In the zygote, DNA methylation of the paternal genome is rapidly erased by an active mechanism (blue line).

Demethylation of the maternal genome is slower (red line) and is dependent on DNA replication (passive demethylation).

These post-fertilisation demethylation events do not include imprinted gDMRs (green dotted line), resulting in parental-allele-specific methylation of these elements in early embryos and consequent parental-allele-specific expression of associated imprinted genes. Concomitant with blastocyst implantation and cell-lineage determination, new methylation landscapes become established, associated with cellular differentiation.

ZFP57, has been shown to be required to maintain the DNA methylation memory at imprints during post-fertilization reprogramming when the bulk of the genome is changing its epigenetic state. ZFP57 binds methylated DNA and is thought to recruit methyltransferases to imprinting control regions hence preventing them from loss of their imprints.

EVOLUTION OF IMPRINTING

Imprinting is not unique to mammals but is known to occur in seed plants and invertebrate species as well.

Imprinting has evolved from the initial observations in mouse embryos to a rapidly expanding field with importance for mammalian development and genetics, and human disease.

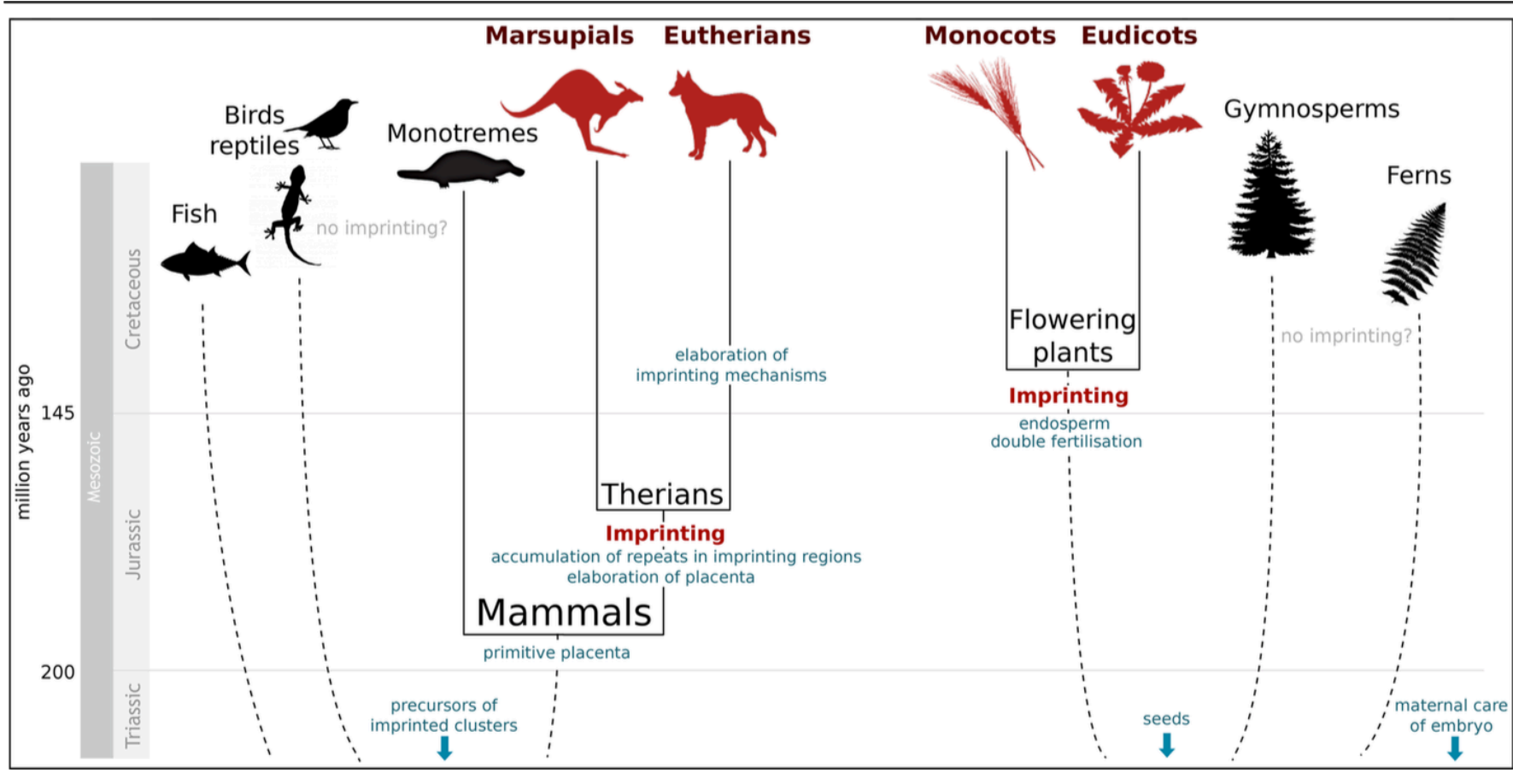

Imprinting evolved independently in flowering plants and in mammals in response to similar selective pressures (many maternally and paternally expressed genes display complementary dosage-dependent effects during embryogenesis)

EVOLUTION OF IMPRINTING: Parental conflict theory

Several hypotheses were introduced to explain this intriguing fact, but the “**sex conflict**” was one the most popular among them. According to this hypothesis, maternal imprinted genes in mammals are responsible for the suppression of foetal growth in order to save maternal resources for subsequent pregnancies. In contrast, paternal imprinted genes are involved in the promotion of foetal growth that provides higher chances of survival for many offspring.



IMPRINTED GENE FUNCTIONS in the embryo and the placenta

Gene	Expressed Allele	Function of Gene Product	Role in Embryo
<i>IGF2</i>	Paternal	Positive regulator of general growth	Growth
<i>H19</i>	Maternal	Negative regulator of general growth	Suppression of growth
<i>IGF2R</i>	Maternal	Negative regulator of general growth	Suppression of growth
<i>GRB10</i>	Maternal	Negative regulator of general growth	Suppression of growth
<i>GRB10</i>	Paternal	Signal adaptor	Aggression
<i>UBE3A</i>	Maternal	Ubiquitin ligase & transcriptional co-activator	Memory, learning, motor function
<i>PEG3</i>	Paternal	Zinc finger protein; control of apoptosis	Sex-specific behavior
<i>NDN</i>	Paternal	Regulator of neuronal growth and differentiation	Spatial learning; socialization
<i>NESP</i>	Maternal	Secretory pathway	Exploratory behavior
<i>GNAS</i>	Maternal	Signal transduction	Cognition & sleep

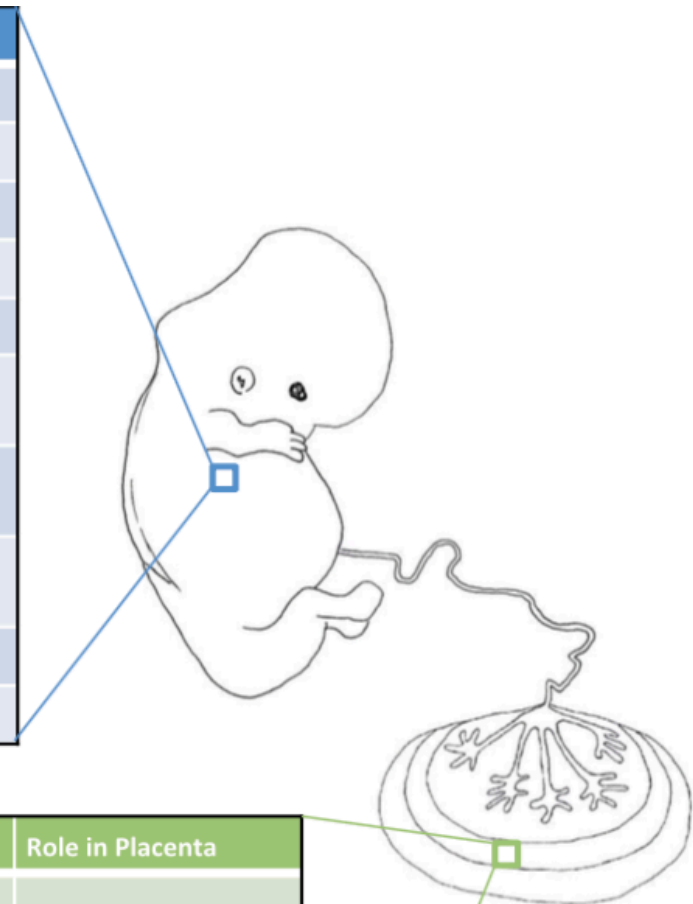

Gene	Expressed Allele	Function of Gene Product	Role in Placenta
<i>PEG3</i>	Paternal	Zinc finger protein; control of apoptosis	Growth
<i>PEG1</i>	Paternal	Hydrolase	Growth
<i>MASH2</i>	Paternal	Helix-loop-helix transcription factor	Songiotrophoblast development
<i>PHLDA2</i>	Maternal	Pleckstrin homology domain protein	Songiotrophoblast restriction
<i>CDKN1C</i>	Maternal	Cell cycle regulator	Songiotrophoblast restriction
<i>SLC22A3</i>	Maternal	Cation transporter	Nutrient transfer

IMPRINTING EVIDENCE

The first evidence of the parental genome's memory in mammals came from experiments conducted by the Surani, McGrath and Solter groups with pronuclei transplantation in mouse zygotes in 1984. These studies were aimed at answering the question about **the absence of parthenogenesis in mammalian reproduction**. These pioneers' studies established that **diploidy alone is not sufficient for embryonic development**, but that a balance of maternal and paternal genomes is strongly required for normal embryogenesis.

Moreover, the impact of parental genomes on embryo development is different. It seems that the **maternal genome** is responsible for the development of the **embryo body** to a greater extent, whereas the **paternal** one is involved in the **support of extraembryonic** tissue differentiation.

Embryological EVIDENCE of imprinting

Cell, Vol. 37, 179-183, May 1984, Copyright © 1984 by MIT

0092-8674/84/050179-05 \$02.00/0

Completion of Mouse Embryogenesis Requires Both the Maternal and Paternal Genomes

Summary

Transplantation of pronuclei between one-cell-stage embryos was used to construct diploid mouse embryos with two female pronuclei (biparental gynogenones) or two male pronuclei (biparental androgenones). The ability of these embryos to develop to term was compared with control nuclear-transplant embryos in which the male or the female pronucleus was replaced with an isoparental pronucleus from another embryo. The results show that diploid biparental gynogenetic and androgenetic embryos do not complete normal embryogenesis, whereas control nuclear transplant embryos do. We conclude that the maternal and paternal contributions to the embryonic genome in mammals are not equivalent and that a diploid genome derived from only one of the two parental sexes is incapable of supporting complete embryogenesis.

Extraembryonic membranes at day 10 of gestation: **yolk sac (YS)** and **trophoblast (TB)**

Removal of a single pronucleus, followed by the introduction of a second pronucleus from another embryo, was used to construct biparental diploid gynogenetic and androgenetic and control (one male and one female pronucleus) nuclear-transplant embryos.

Maternal and paternal genomic contributions are not functionally identical and both are essential to complete embryogenesis.

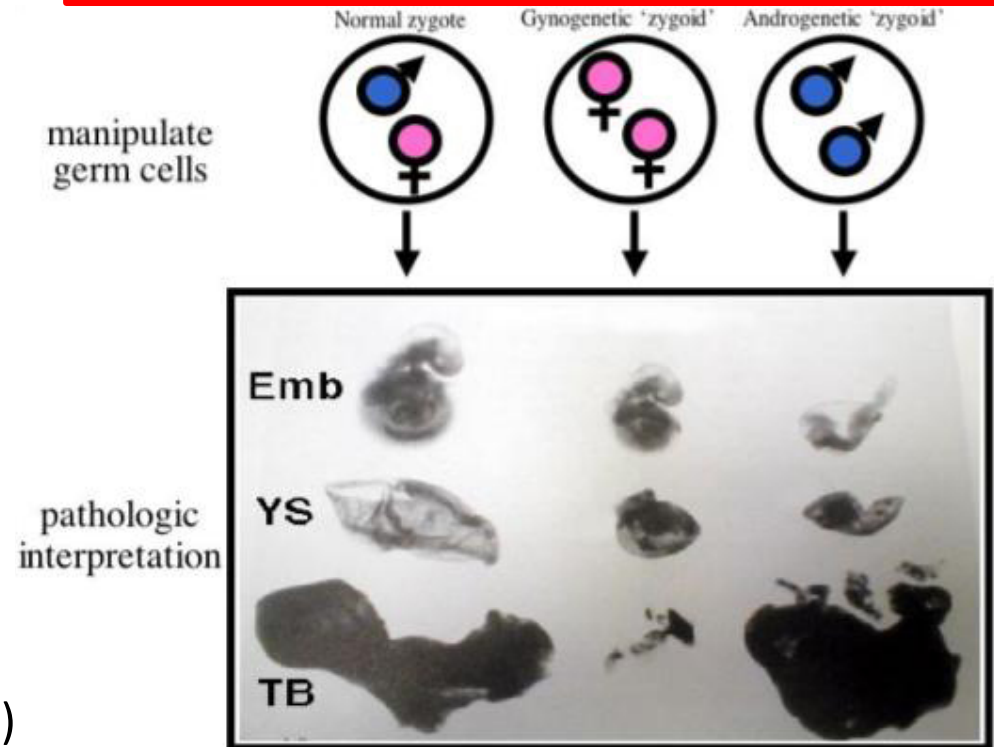

Surani, McGrath and Solter, 1984-1987

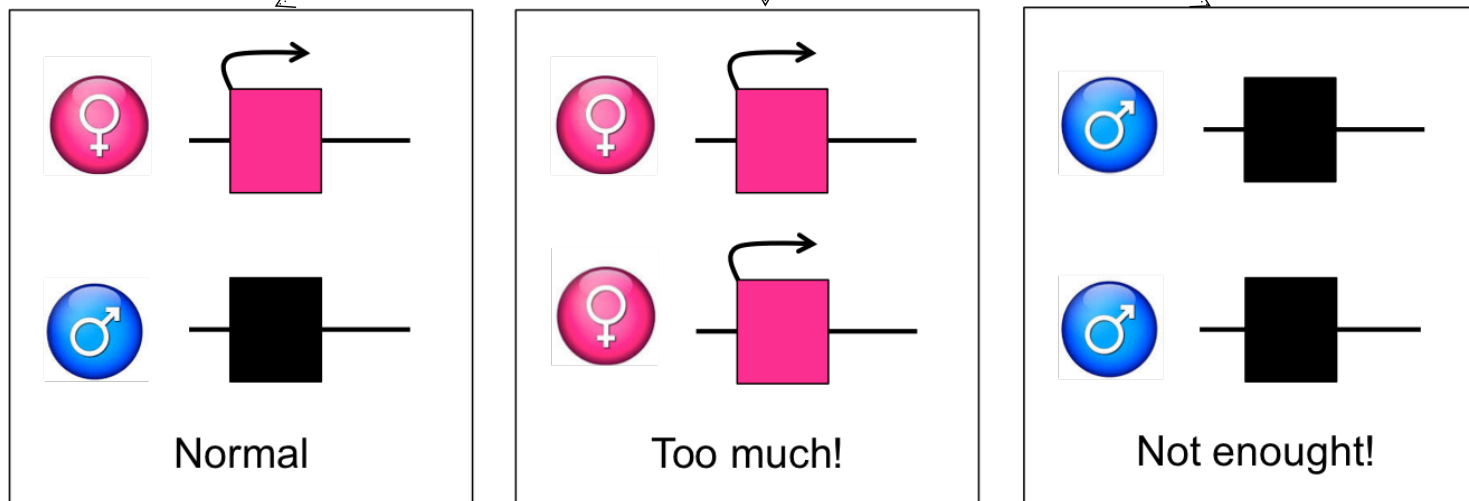
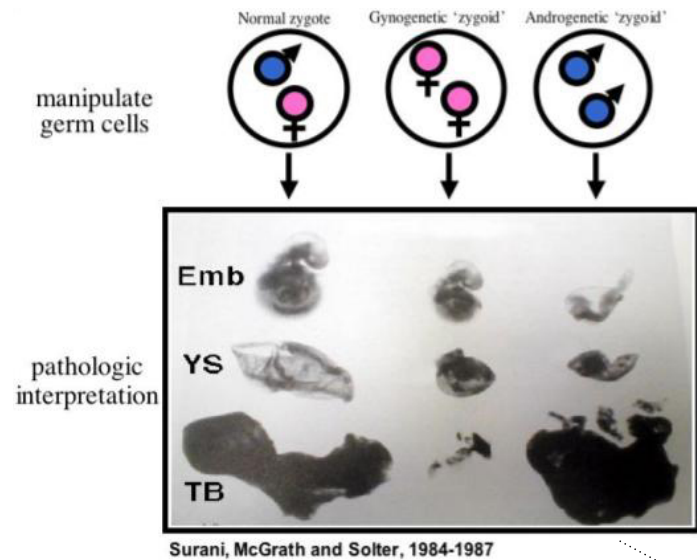

Many imprinted genes influence fetal growth and development. Imprinted genes that enhance growth are mostly expressed from the paternal allele. Several other imprinted genes, which reduce growth, are expressed from the maternal allele.

Specific chromosomal domains are subject to imprinting

TRANSLOCATION AS EVIDENCE FOR IMPRINTING

UNIPARENTAL DISOMY FOR INDIVIDUAL CHROMOSOME

1. chromosomal fusion occurs

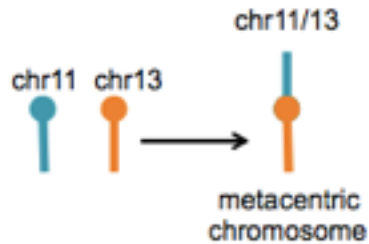

2. mouse's diploid genotype is this



3. chromosomes can segregate many different ways in meiosis

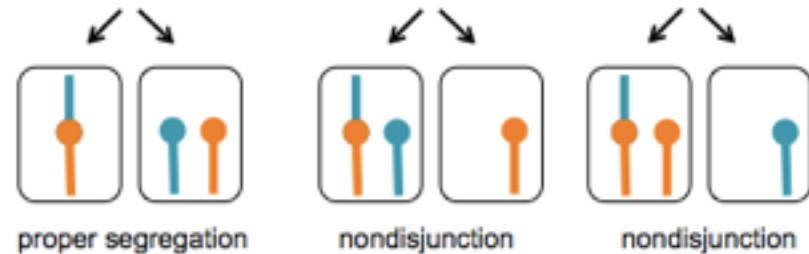

4. cross males and female mice heterozygous for the fusion

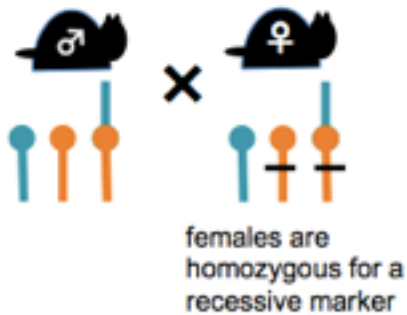

5. some combinations of gametes result in uniparental disomy

	☺	☺	✗	✗	✗	✗	✗
	☺	☺	✗	✗	✗	✗	✗
	✗	✗	✗	UD	✗	✗	✗
	✗	✗	✗	✗	✗	✗	UD
	✗	✗	✗	✗	✗	✗	UD

6. maternal and paternal disomy have reciprocal effects

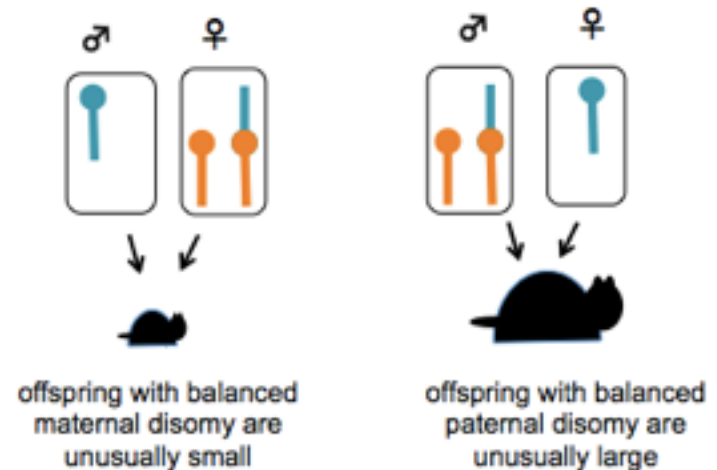

Uniparental disomy refers to the situation in which 2 copies of a chromosome come from the same parent, instead of 1 copy coming from the mother, and 1 copy coming from the father.

Imprinted chromosomal domains in the mouse with the associated developmental phenotypes in maternal (indicated to the left) and paternal (to the right) disomies.

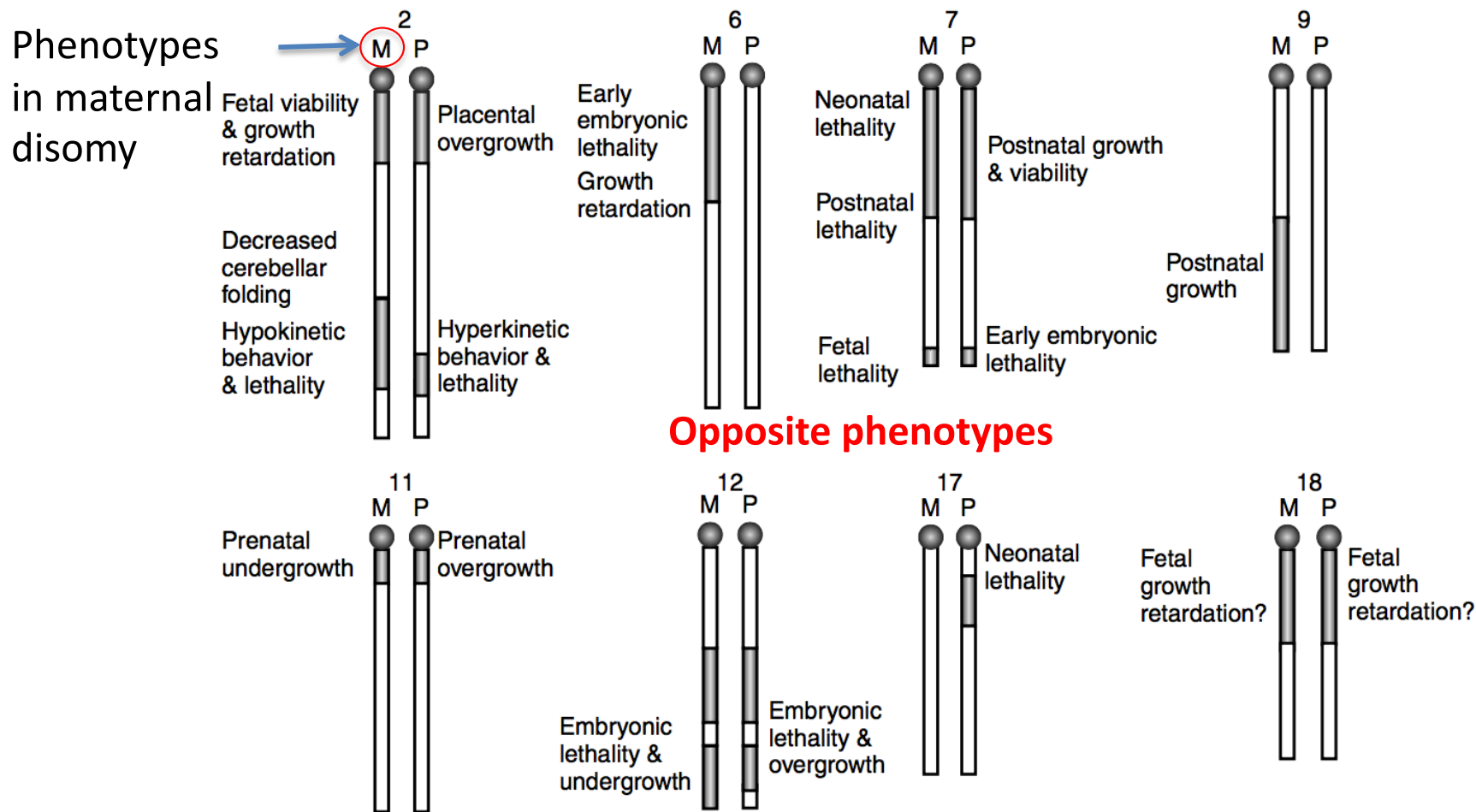

In total, 12 chromosomal regions with imprinting phenotypes have been identified on 8 different autosomal chromosomes. The large majority of the known imprinted genes maps to these chromosomal regions. Probably, the remainder of the genome comprises few imprinted genes or contains imprinted genes that give rise to minor phenotypes only when present in two maternal or two paternal copies.

PROXIMAL PORTION OF MOUSE CHROMOSOME 11

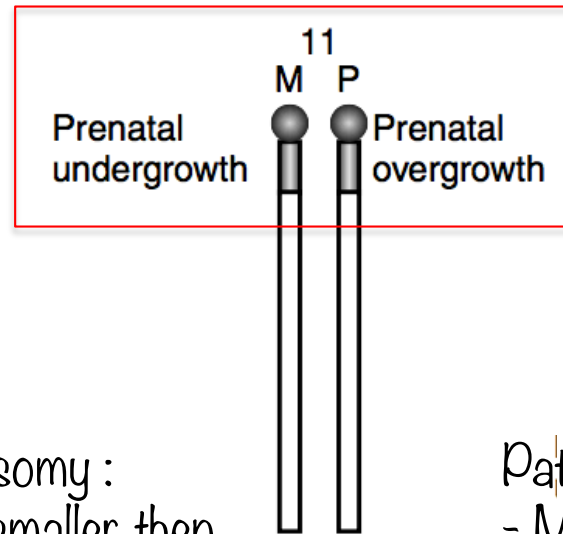

Maternal disomy :
- Mice are smaller than their normal littermates

Paternal disomy:
- Mice are larger than their normal littermates

Two imprinted genes have been identified in this domain, **U2af1-rsl** and **Grb10**. The latter could be responsible for the phenotypes of the maternal and paternal disomies. Its main embryonic transcript is expressed from the maternal allele only, and it encodes a protein with a negative effect on the growth-regulating IGF/INS pathway.

How does a growing organism regulate its size and body proportions?

Grb10 Is a Negative Regulator of Growth (negative regulator of insulin signaling and other growth-related pathways)

Grb10 has functional roles in embryonic development, cellular growth, and behavior.

During development, both **body size** and **proportions** are influenced by the combined actions of **Grb10** in the mother, controlling nutrient supply, and **Grb10** in the offspring, controlling demand. When the supply/demand balance is disrupted, body proportions during development are perturbed, programming altered glucose homeostasis in later life.

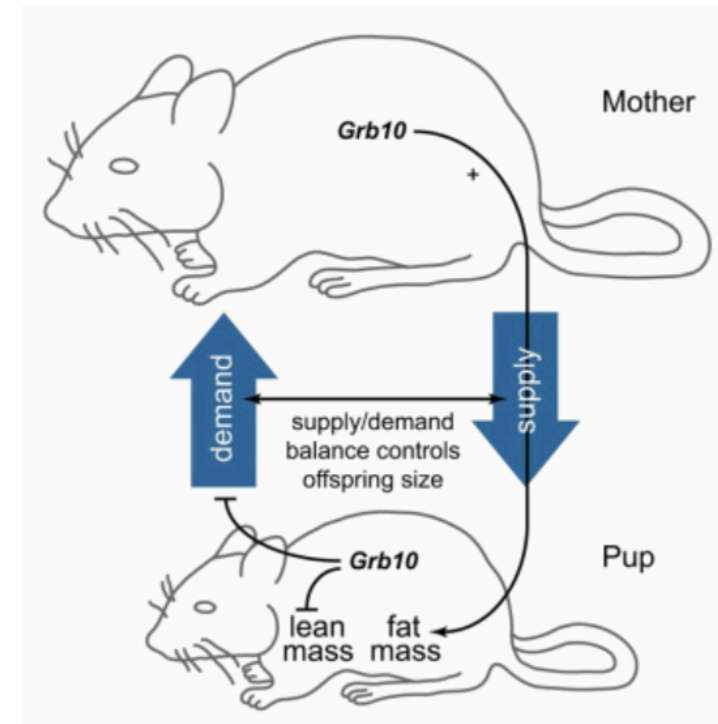

Interactions between maternal and offspring *Grb10* control body size and proportions. From Cowley et al (2014), PLoS Biol.

Grb10 has a role in modulating **social behaviour**. This is particularly intriguing because it is the paternally-inherited allele of *Grb10* which performs this role, whilst the growth control functions of *Grb10* are mediated by the maternally-inherited allele.

This is the first example of a gene demonstrating different functions for its parental alleles.

Grb10's role

Grb10's role in insulin signaling is the most well understood, where it acts as an inhibitor. When **IR** binds insulin, a cascade of phosphorylation events ultimately activates the **PI3K/AKT and MAPK pathways**. Activation of these two pathways leads to a variety of metabolic consequences affecting the storage and synthesis of glucose and fatty acids, in addition to **promoting cellular growth** through regulating proteins important for the cell cycle and other mitogenic factors.

Additionally, both pathways can activate **mTORC1**, a protein complex that integrates growth signals and **acts positively upon cell proliferation**.

Grb10 inhibits insulin signaling by interacting with IR in response to insulin stimulation. Once bound, Grb10 inhibits the catalytic activity of IR. Additionally, Grb10 has recently been described as a phosphorylation substrate of the mTORC1 complex. Phosphorylation and stabilization of Grb10 by mTORC1 leads to the feedback inhibition of PI3K/AKT and MAPK pathways, downstream of IR.

Insulin-like growth factor (IGF) signaling is inhibited by Grb10 directly binding and degrading IGF1R through its interaction with NEDD4, a ubiquitin protein ligase. Grb10 has also been implicated as a negative regulator of growth-hormone signaling through direct interaction with GRH

A minority of imprinted genes are not part of an imprinted gene cluster

A minority of imprinted genes are not part of an imprinted gene cluster. One of these is the U2af1-related sequence-1 gene (*U2af1-rs1*) on proximal mouse chromosome 11. This intronless gene is repressed on the maternal chromosome and encodes a **brain-specific RNA splicing factor** homologous to the splicing factor U2AF. The imprinted *U2af1-rs1* gene has arisen via a retrotransposition event in rodents, and in humans there is no equivalent imprinted gene.

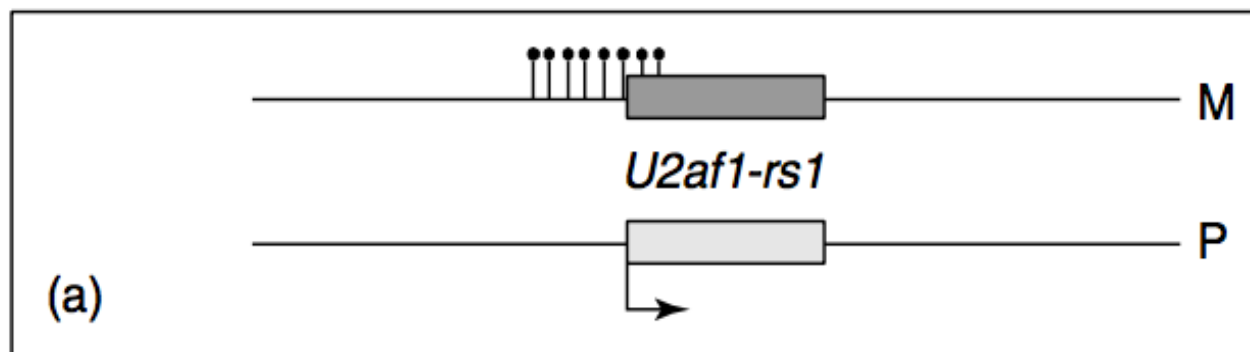

DISTAL PORTION OF MOUSE CHROMOSOME 2

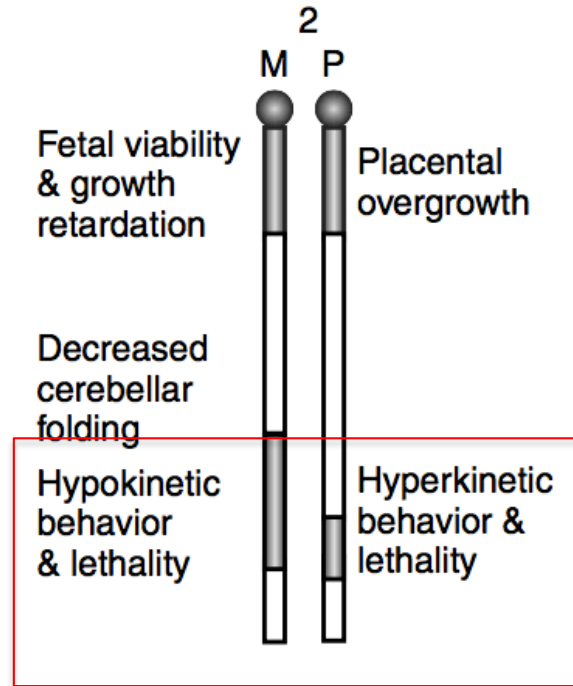

Maternal disomy is associated with reduced activity after birth

Paternal disomy gives offspring that are hyperactive

Such behavioral phenotypes emphasize that **imprinted genes can affect behavior**. A small number of imprinted genes were discovered on distal mouse chromosome 2. Two of these have neuroendocrine functions (*Gnas* and *Gnas-x1*) and are involved in the behavioral phenotypes of the maternal and paternal disomy mice.

DISTAL PORTION OF MOUSE CHROMOSOME 7

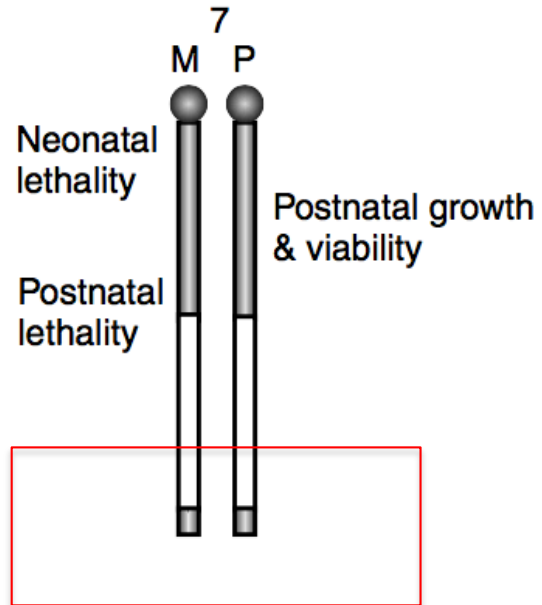

Maternal disomy leads to:

- reduced growth
- fetal death

Paternal disomy leads to:

- enhanced growth
- embryonic death

10 imprinted genes have been mapped to the DISTAL PORTION OF MOUSE CHROMOSOME 7.
 Several of these are part of the insulin-like growth factor/insulin signaling pathway (IGF/INS pathway)

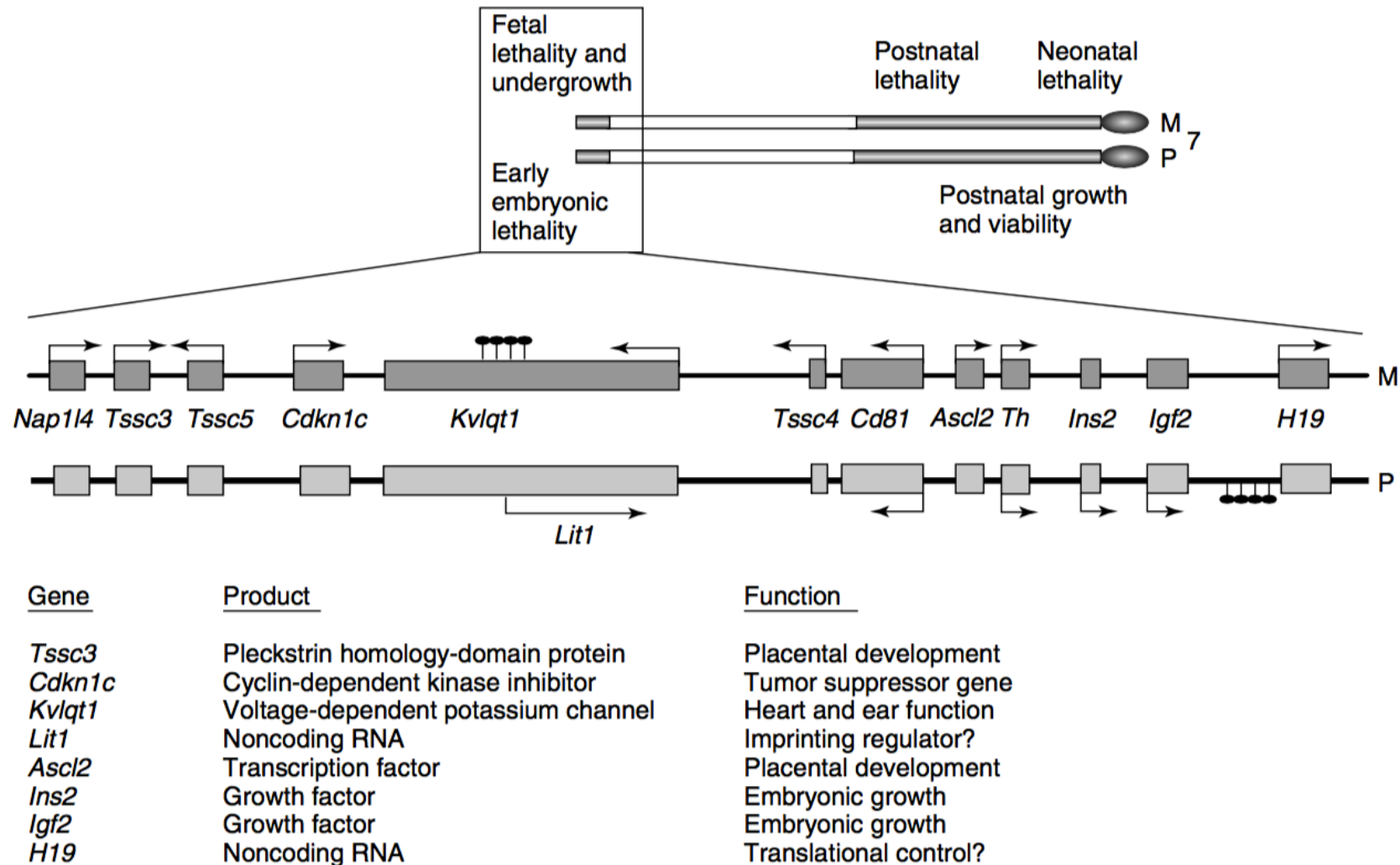
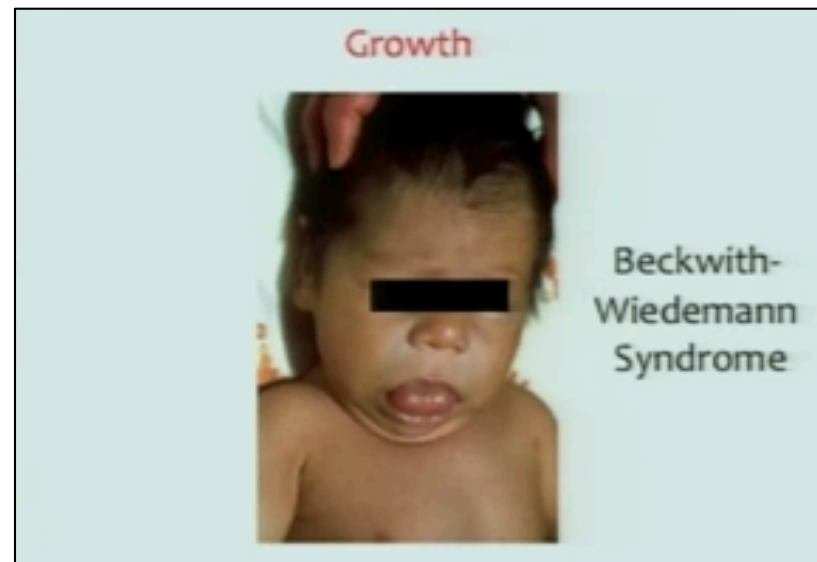

Fig. 4 The imprinted domain on distal mouse chromosome 7 (human chromosome 11q15). Shown are the imprinted genes and their known functions. Lollypops indicate the allele-specific DNA methylation at the two imprinting-control regions.

The corresponding chromosomal region in humans, chromosome 11p15.5, is involved in the Beckwith - Wiedemann syndrome (BWS), a human growth disorder that can be caused by paternal disomy of this imprinted region.



Genomic Imprinting

Two mechanisms have been described for mediating imprinting in clusters:

1. Silencing through *in cis* ncRNA (macro-ncRNA) transcription
2. Silencing through the insulator

It is possible that both mechanisms are used, but in a tissue-specific manner.

Silencing through *in cis* ncRNA transcription

Insulator model of Imprinting

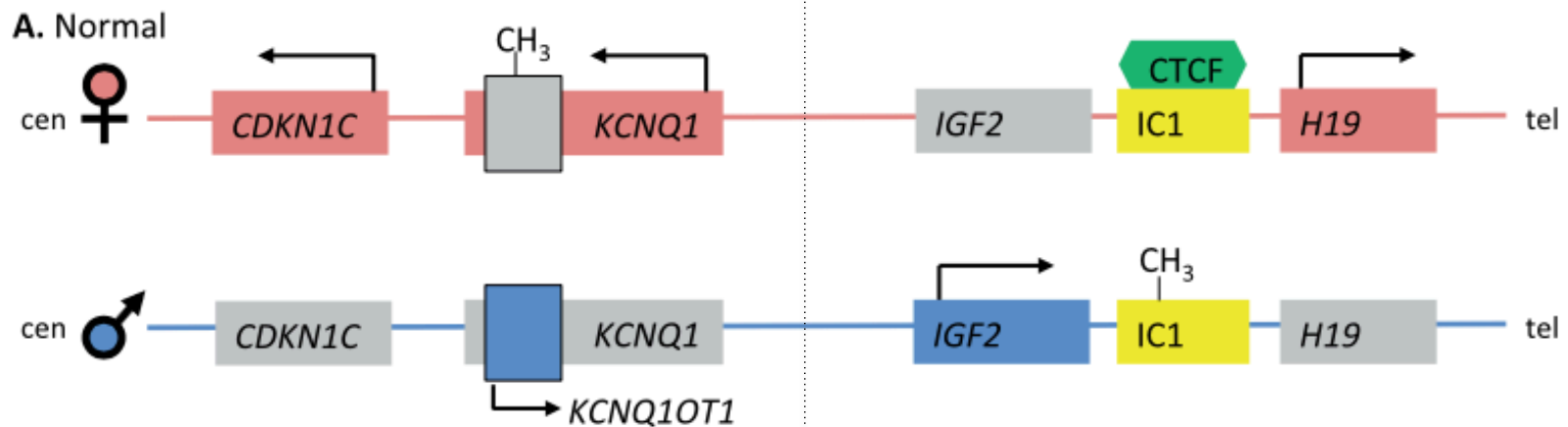

Insulator model of Imprinting

The insulator model is exemplified by the *H19/Igf2* locus. Here, the intergenic ICR is paternally methylated. On the unmethylated maternal allele, CTCF binding prevents enhancers from interacting with the *Igf2* promoter. Instead, the enhancers activate *H19* lncRNA expression, which inhibits paternal allele expression by recruiting MBD1 and KMT. On the paternal allele, methylation of the ICR spreads to the *H19* promoter, silencing its expression, and prevents CTCF from binding the ICR, allowing the enhancers to activate *Igf2* expression.

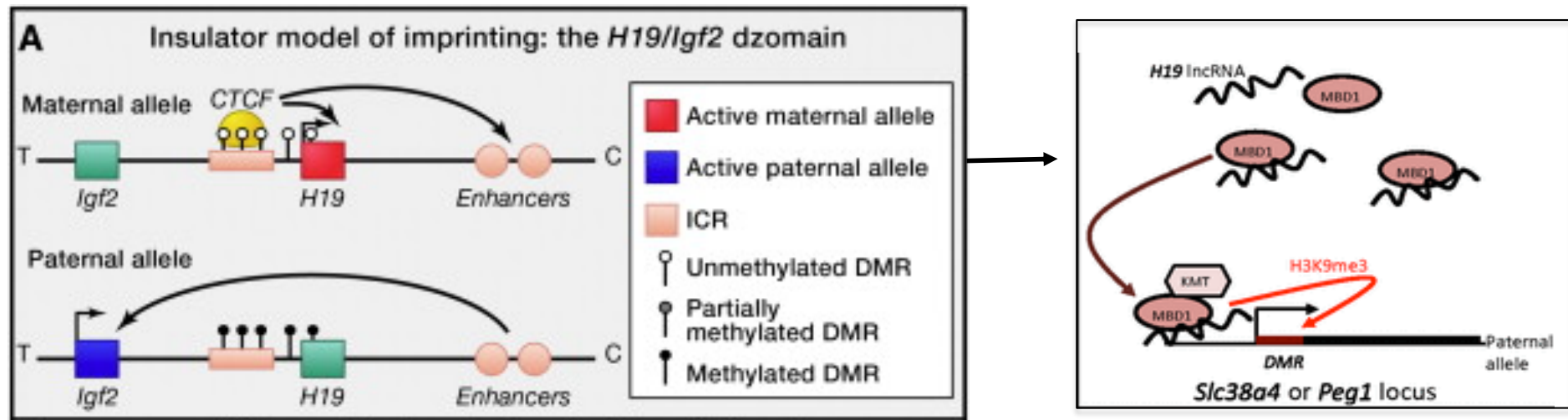

It remains to be determined how DNA methylation is recruited to specific CpGs. Recently, a link has been found between histone methylation and DNA methylation suggesting that patterns of histone methylation could dictate patterns of DNA methylation, which could then be stably inherited.

Chromatin loop formation

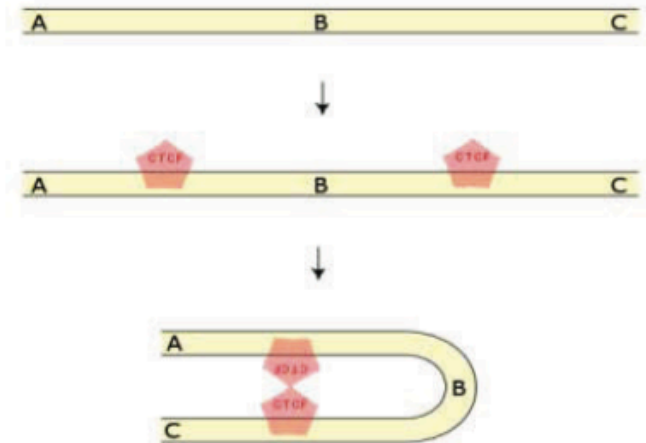
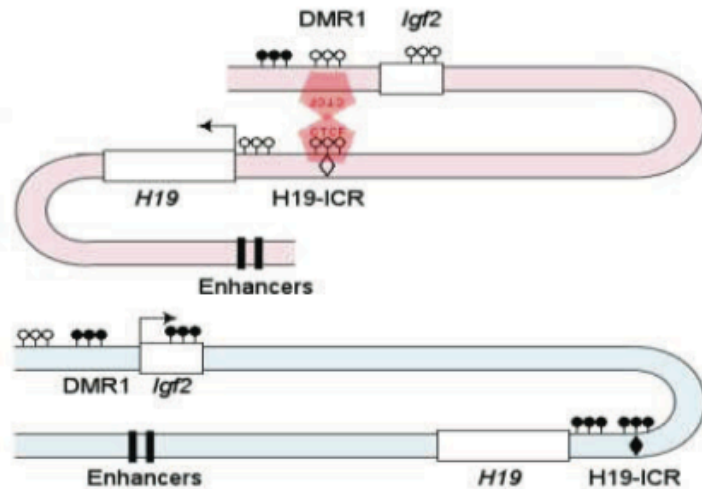

In the H19-Igf2 imprinted locus CTCF (red pentagon) binds to regions flanking Igf2 and dimerizes, looping the gene and physically inhibiting its interaction with distal enhancers. On the paternally inherited allele, CTCF does not bind and enhancers are in contact with Igf2 and the gene is expressed; right: Model; **Looping of DNA sequences through the action of CTCF (red pentagon) can separate regions or bring them into contact;**

The model suggests that on the unmethylated maternally inherited chromosome, CTCF binds to the ICR and also to **an upstream somatic DMR** located 5' of *Igf2*

Insulator model of Imprinting

Grb10 is expressed maternally from most adult tissues and paternally in neuronal tissues.

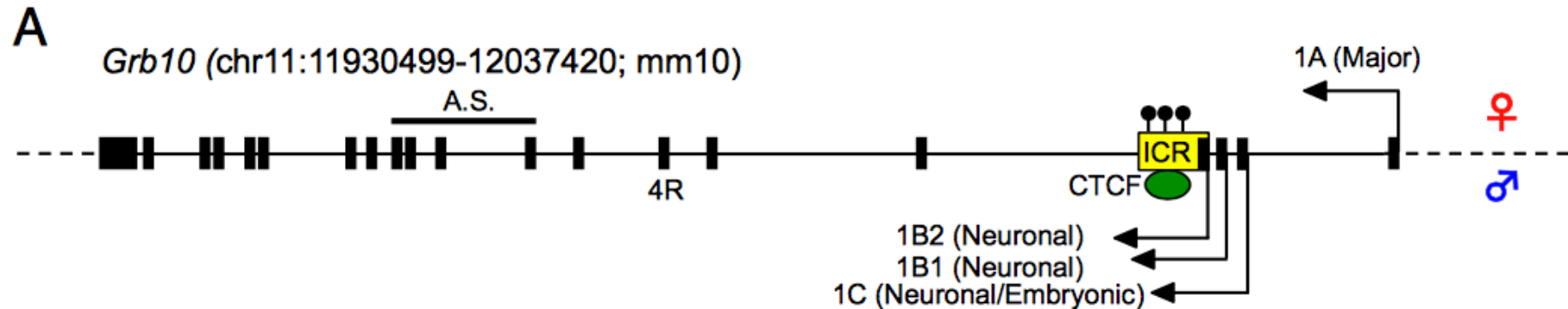

Grb10 is expressed from the maternal chromosome in **most tissues** in the mouse but is expressed from the paternal allele in a subset of neurons. Maternal expression occurs from the *Grb10* major promoter whereas *Grb10* paternal expression comes from three downstream alternative promoters. The region surrounding one of these alternative promoters has been identified as an ICR, which exhibits DNA methylation only on the maternal allele in all examined tissues. On the paternal allele, the unmethylated *Grb10* ICR is bound by CCCTC-binding factor (CTCF), a multifunctional transcription factor, which is recruited in a DNA methylation-sensitive manner

In **motor neurons** there is a switch of *Grb10* promoter used. Specifically, the maternally expressed major promoter is repressed whereas the paternally expressed neuron-specific promoter is activated, concordant with neuronal maturation.

ncRNA model of Imprinting (*Kcnq1*)

For *Kcnq1* domain, the ICR contains the promoter of the *Kcnq1ot1* lncRNA. On the paternal allele, the ICR is unmethylated, allowing *Kcnq1ot1* expression. *Kcnq1ot1* expression silences the paternal allele of the linked genes in cis. On the maternal allele, *Kcnq1ot1* is not expressed due to methylation of the ICR, and the adjacent imprinted genes are expressed.

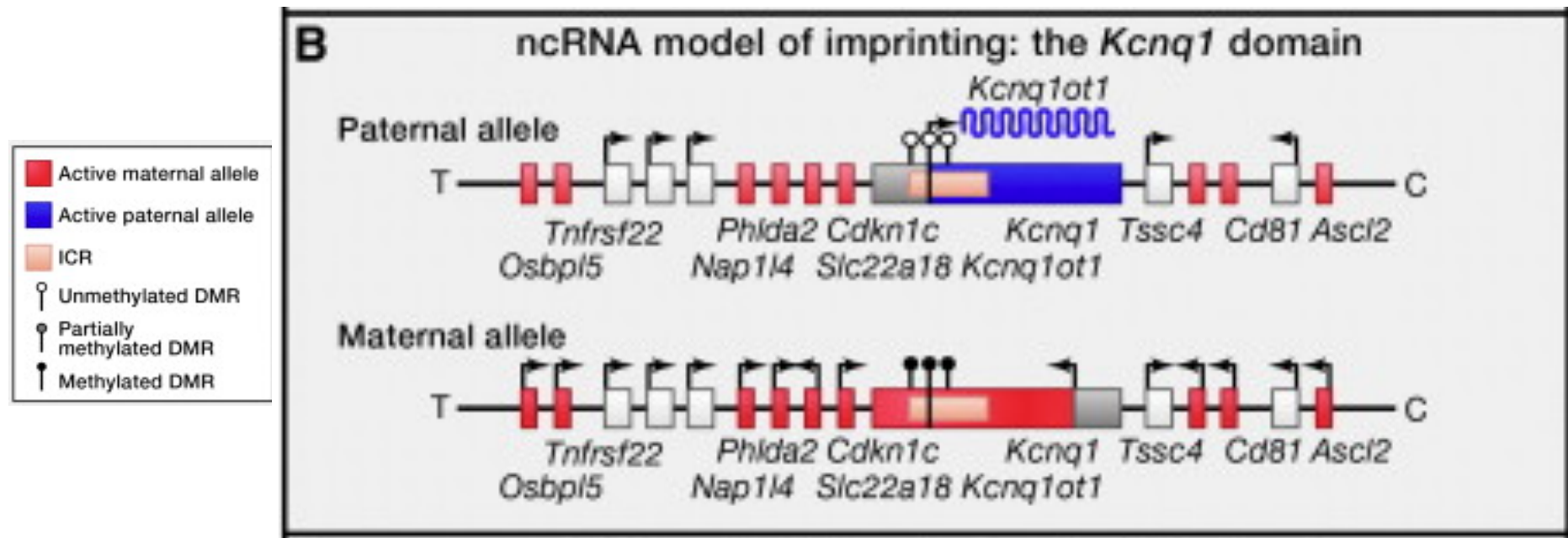

Mechanisms that control imprinting in the placenta differ from those mechanisms that regulate imprinting in somatic lineages.

Mechanisms for lncRNA-mediated imprinting

Paternally expressed *Kcnq1ot1* RNA interacts with chromatin in cis and recruits histone modifying complexes, such as PRC2, PRC1 and G9a, to the promoters of imprinted genes. This promotes the establishment of repressive heterochromatin and silencing of **placental-specific imprinted genes**. *Kcnq1ot1* RNA establishes the repressive chromatin of imprinted genes in the *Kcnq1* locus via a multilayered silencing pathway involving both repressive histone modifications and DNA methylation.

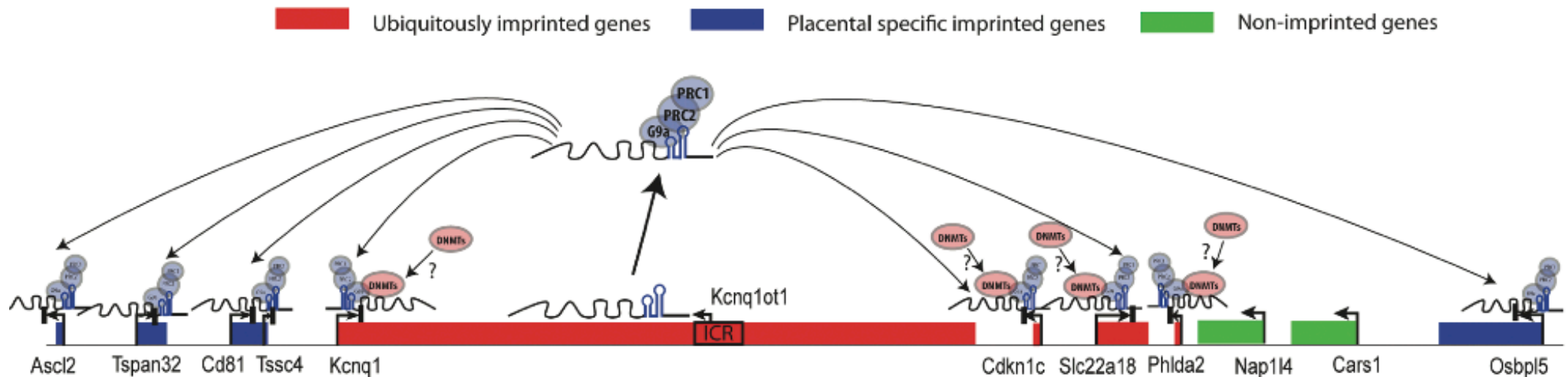

ncRNA model of Imprinting (*Igf2*)

For the *Igf2r* locus, transcription of the *Airn* lncRNA is governed by a promoter within the ICR and is expressed from the unmethylated paternal allele. In somatic cells, transcription of *Airn* over the *Igf2r* promoter precludes *Igf2r* expression, in part by kicking RNA polymerase II (POL-II) off of the promoter. In **extraembryonic** lineages (placenta), *Airn* lncRNA recruits enzymes that confer repressive histone modifications to silence genes in cis (*Scl22a1/a2*).

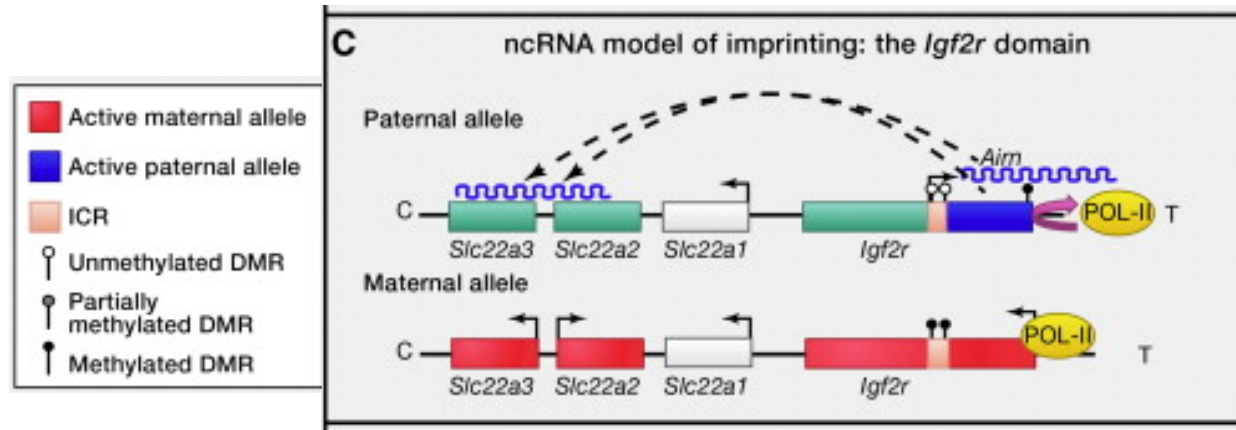

Interestingly, mechanisms that control imprinting in the placenta—a short-lived organ—may differ from those mechanisms that regulate imprinting in the much longer-lived somatic lineages.

Silencing through *in cis* ncRNA transcription

In the *Igf2r* locus, the silencing of the overlapping *Igf2r* gene is mediated by the *Airn* transcription itself, whereas *Airn* RNA mediates the silencing of the non-overlapping placentally imprinted genes through the recruitment of G9a → H3K9me.

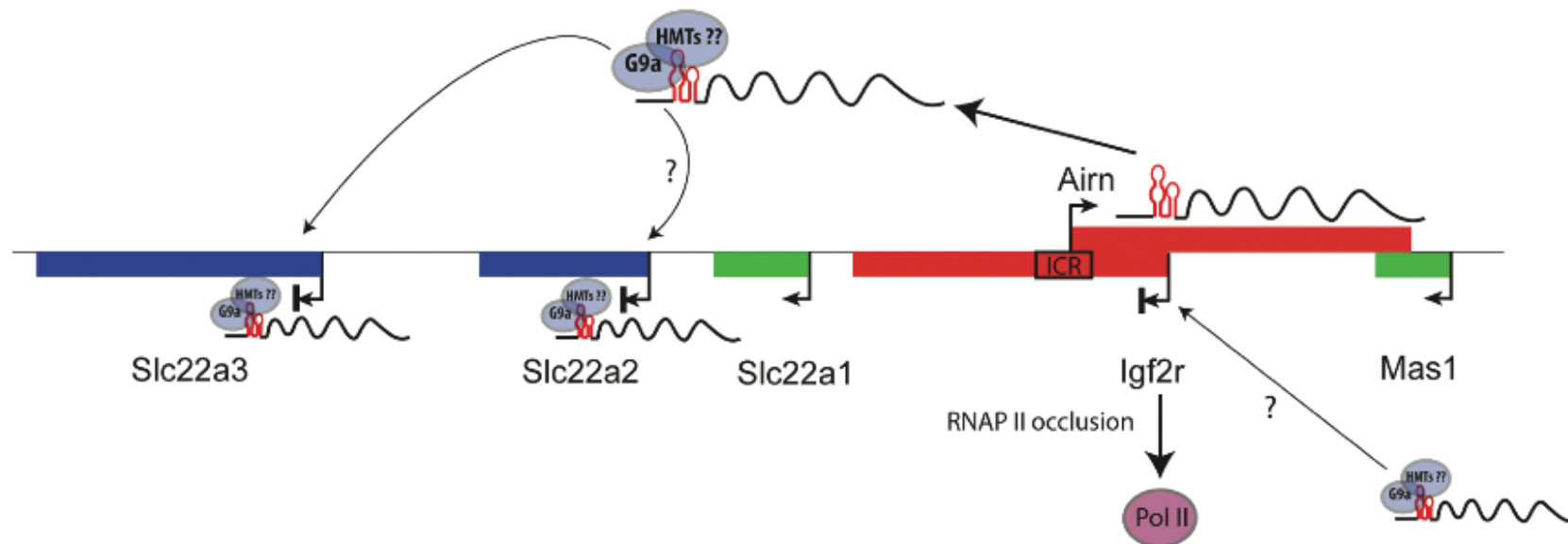

Ubiquitously imprinted genes Placental specific imprinted genes Non-imprinted genes

Airn can work by transcriptional overlap

Igf2r silencing does not require any part of the *Airn* lncRNA, but only transcription through the *Igf2r* promoter. To test the role of *Airn* transcription versus product in *Igf2r* silencing, they used homologous recombination in embryonic stem (ES) cells to insert polyadenylation (polyA) cassettes on the paternal chromosome that truncate *Airn* to different lengths.

Truncation of *Airn* from the 3' end (3' trunc) after but not before the *Igf2r* promoter maintains *Airn*-mediated silencing (middle). The *Airn* promoter was also moved close to the *Igf2r* promoter (5' trunc): *Igf2r* was silenced in this case too (bottom). *Airn* only needs to overlap the *Igf2r* promoter to silence it, 3' and 5' sequences are not necessary

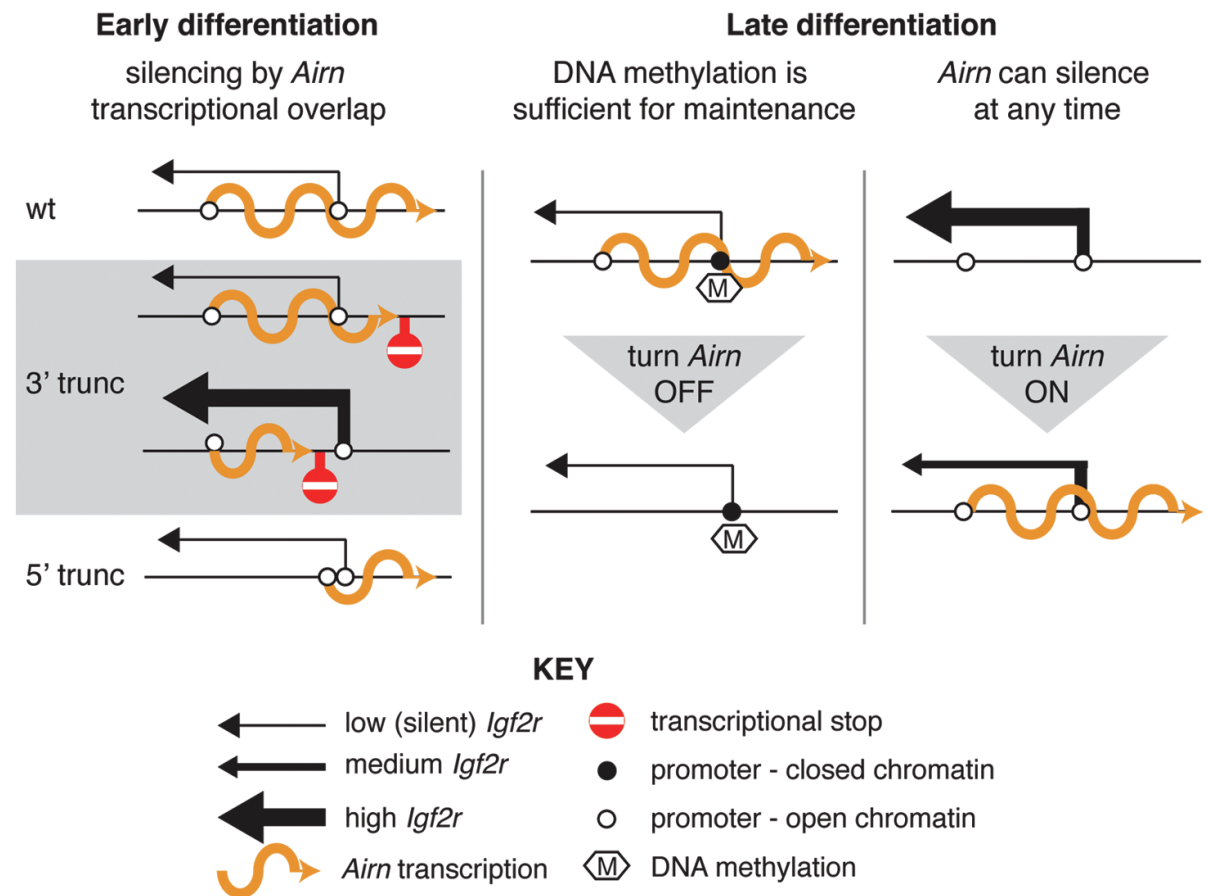

Imprinted macro ncRNAs might use different modes of silencing in embryonic and placental tissues

In **embryonic tissues**, only a few genes are silenced by the ncRNA in the *Kcnq1* and *Igf2r* clusters. No localisation of the ncRNA to chromatin has been reported in the embryo. The **transcription of the ncRNA** is sufficient to silence all genes by interfering with the binding of essential transcription factors (black ellipse), thereby inducing gene silencing by interrupting enhancer interactions (dashed arrows).

B Embryo: promoter-specific/regulator transcription interference

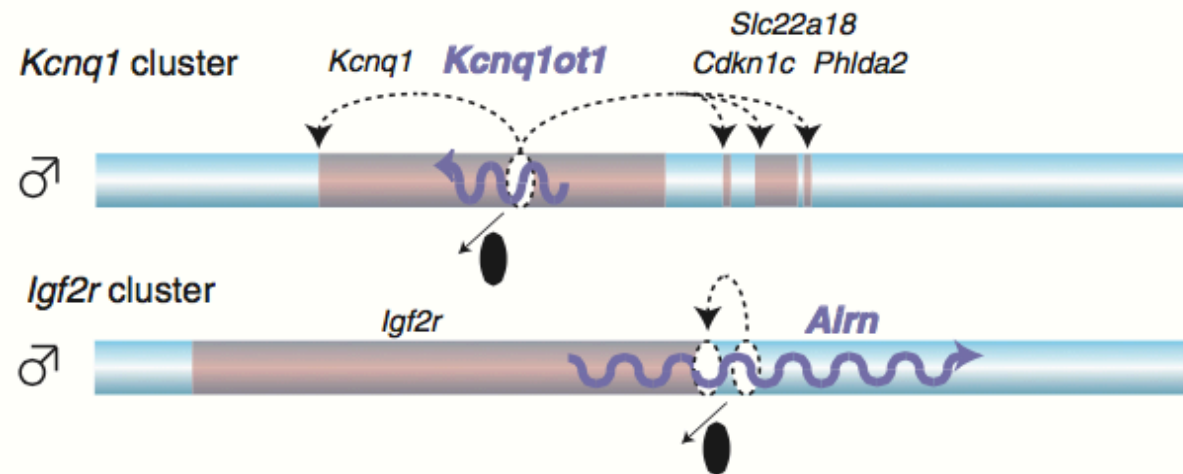

Key:

- Transcription factor
- Transcription factor binding site
- 3D interaction
- ↘ Blocked enhancer interaction
- ⤞ ncRNA
- Silent imprinted allele

Imprinted macro ncRNAs might use different modes of silencing in embryonic and placental tissues

In the **placenta**, *Kcnq1ot1* in the *Kcnq1* cluster is transcribed from the paternal allele and localises to the whole imprinted domain, inducing the recruitment of repressive histones, which leads to gene silencing. In the *Igf2r* cluster, *Airn* locates to the silent *Slc22a3* promoter recruiting repressive histone modifications that silence *Slc22a3*. In both cases, **the ncRNA itself** is involved in the silencing process.

A Placenta: large silent domain, RNA-directed silencing

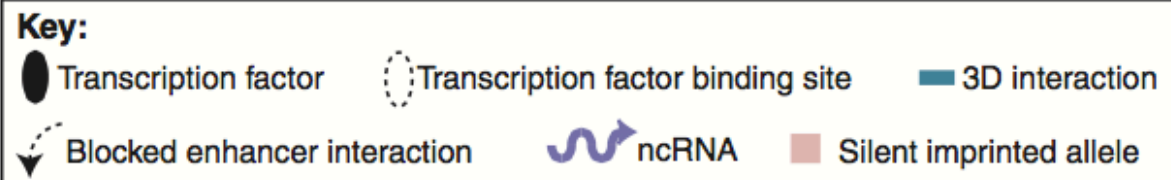
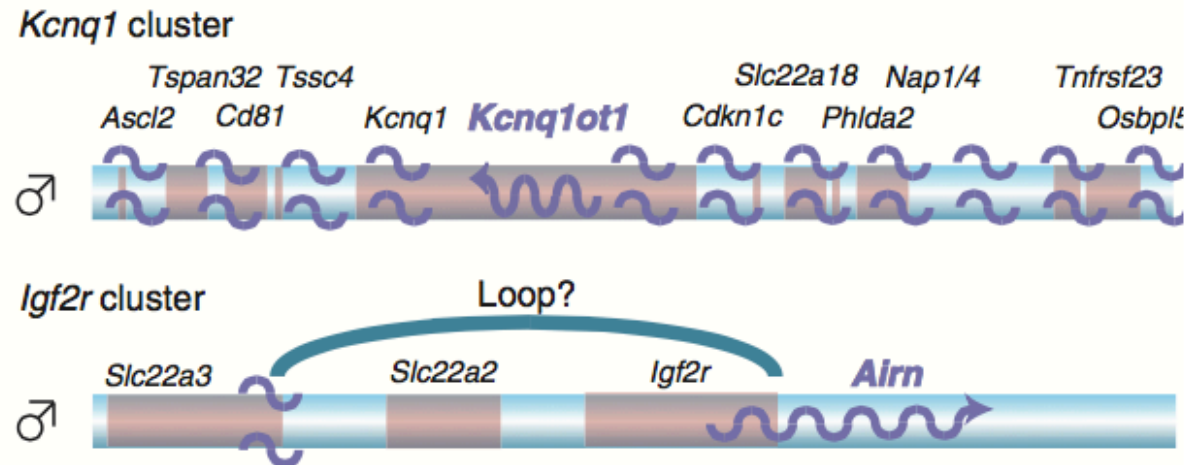

X Chromosome Inactivation (XCI)

Inactivation of the paternally inherited **X** is initiated in cleavage-stage embryos. **Imprinted inactivation** (yellow) of the paternally inherited **X** is maintained in the developing extra-embryonic lineages. In the **inner cell mass** of blastocysts, reactivation of the inactive **X** (**Xi**) occurs specifically in cells that will form the embryo (**blue**). Subsequently, both X chromosomes are active in the cells of the developing epiblast between embryonic day 3.5 (E3.5) and E5.5 (blue). Random XCI (red) of either the paternally or maternally inherited X chromosome is initiated around E5.5. Once established, the XCI pattern is maintained in the somatic lineages of female mice. In the developing germ line, the Xi is reactivated such that both X chromosomes are active in oogenesis.

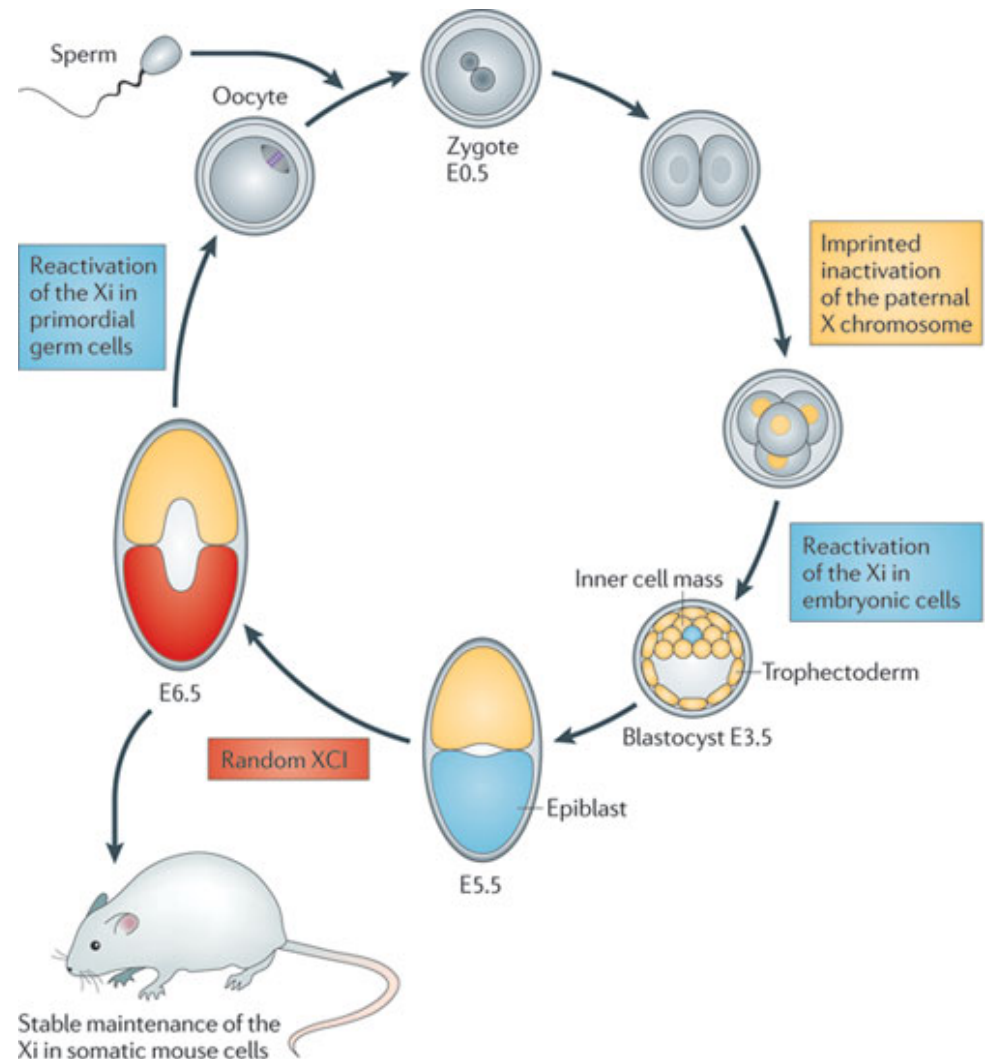

X Chromosome Inactivation Center (Xic)

- XCI is regulated by cis-acting master control regions the **X Chromosome Inactivation Center (Xic)** that has been mapped to a 100–500 kb region. Genetic analyses based on knockouts, gain-of-function mutations, and transgenic overexpression have shown that the Xic is necessary and sufficient to regulate XCI.
- XIC controls expression of the *XIST* gene (X-inactive-specific transcript) that produces a 17-20 kb ncRNA molecule. Xist ncRNA “coats” the entire *local* X-chromosome – *cis*-acting.
- Deleting the noncoding locus Xist results in loss of silencing capability (1996) and female-specific lethality.



Xist localization to the X chromosome

X Chromosome Inactivation-mechanisms

- Initial *XIST* RNA expression and coating
- Association of chromatin modifying proteins (HDACs, PRCs and other proteins)
- DNA methylation of X-chromosome genes
- Modification of histones by HMTs (H3K27me3 and H3K9me3) and hypoacetylation
- Recruitment of the histone variant macroH2A
- DNA methylation within the CpG island
- Formation of condensed chromatin

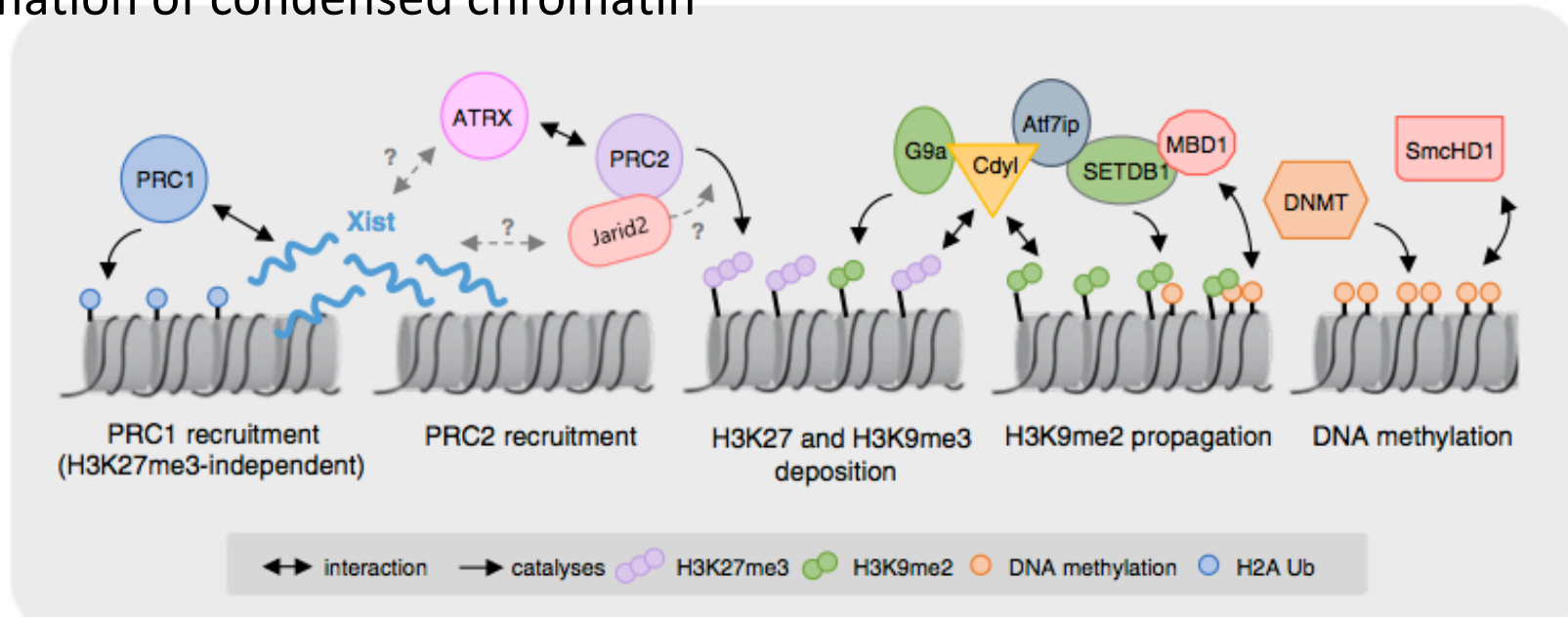

RAP-MS identifies direct *Xist*-interacting proteins

RAP-MS uses ultraviolet (UV) crosslinking to create covalent bonds between directly interacting RNA and protein and purifies lncRNAs in denaturing conditions to disrupt non-covalent interactions. lncRNAs are purified with antisense biotinylated oligonucleotides and the interacting proteins are identified by quantitative mass spectrometry.

This UV-crosslinking and denaturing approach is known to identify only direct RNA-protein interactions and to separate interactions that are crosslinked in the cell from those that merely associate in solution.

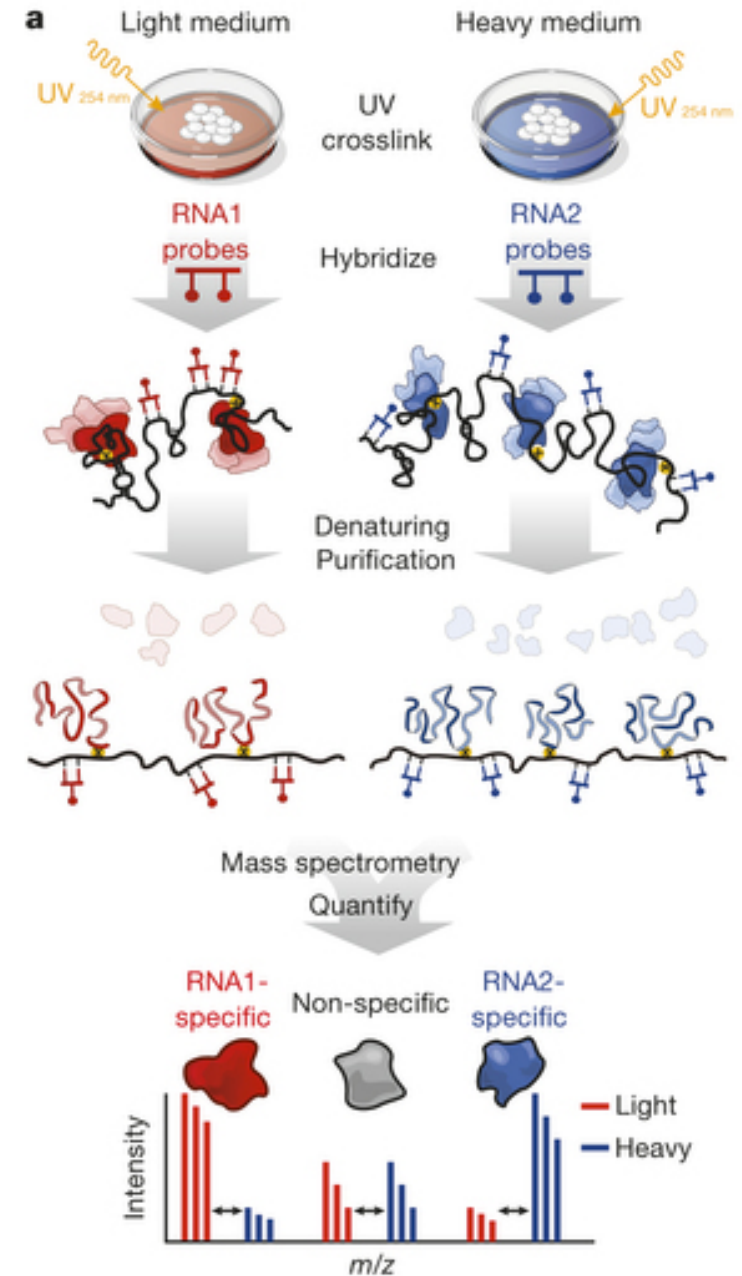

A model for *Xist*-mediated transcriptional silencing

Xist can localize to sites on the X chromosome by binding to the **SAF-A** protein, which is known to interact directly with chromatin. *Xist* interacts directly with **SHARP** to recruit **SMRT** to these DNA sites across the inactive X chromosome. This *Xist*-SHARP-SMRT complex recruits/activates **HDAC3** across the X chromosome. Through HDAC3, *Xist* can direct the removal of activating histone acetylation marks on chromatin, thereby compacting chromatin and silencing transcription. Upon initiating the silenced state, *Xist* recruits **PRC2** across the X chromosome in an HDAC3-dependent manner, either through a direct interaction between PRC2 and HDAC3 or indirectly through HDAC3-induced transcriptional silencing or chromatin compaction (PRC2 is responsible for H3K27me3 an histone repressive modification).

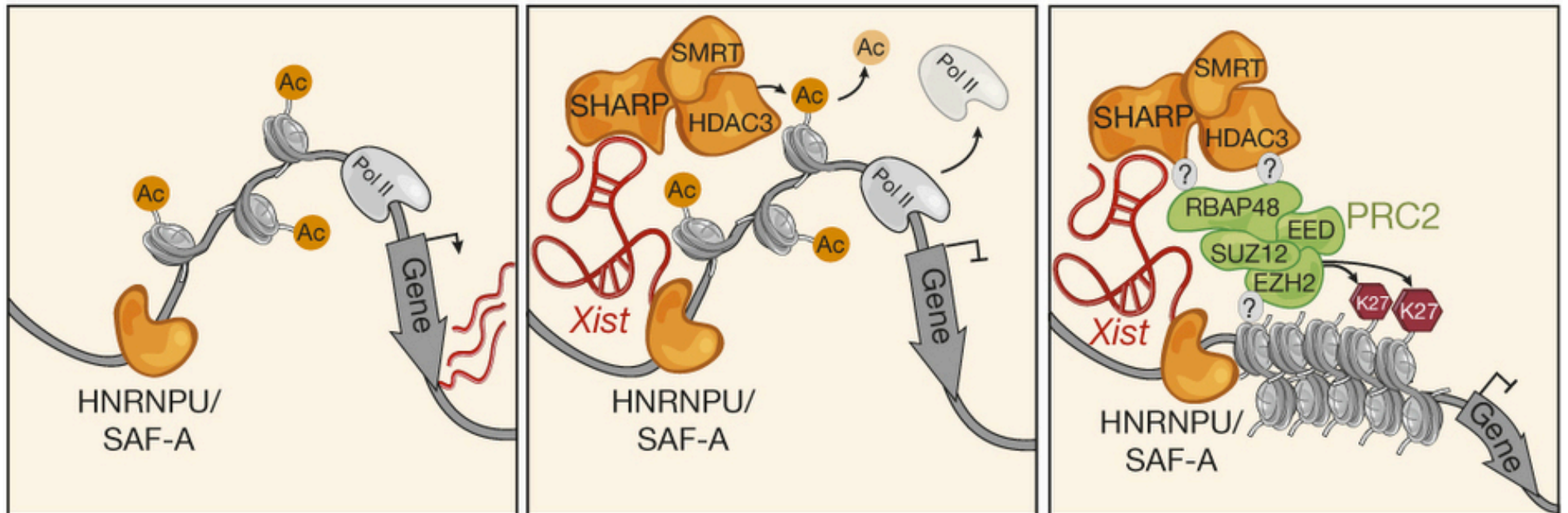

Xic lncRNAs

The X-inactivation center contains multiple genes encoding lncRNAs, including *Xist*, *Tsix*, *Xite*, *Jpx/Enox*, *Ftx*, and *Tsx*. Many of these loci regulated *Xist* expression, some acting negatively (e.g., *Tsix*), others positively (e.g., *Jpx*).

However, whether these loci act through their transcription, RNA product or DNA elements, and at which of these levels *Xist* is regulated, remain open questions.

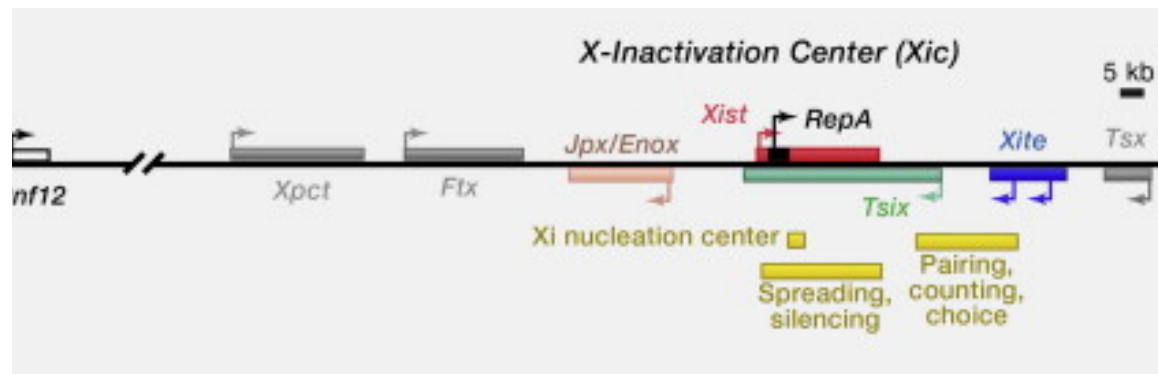

Tsix RNA repressed Xist expression

Tsix is transcribed antisense across Xist, and represses *Xist* by preventing its upregulation *in cis*. Current evidence points to the act of transcription, rather than Tsix RNA, acting repressively on Xist expression.

Tsix also participates in mediating the choice of the future inactive X chromosome. helping mediate choice during random XCI. Tsix has been also proposed to prevent Xist activation on the maternal X during imprinted XCI.

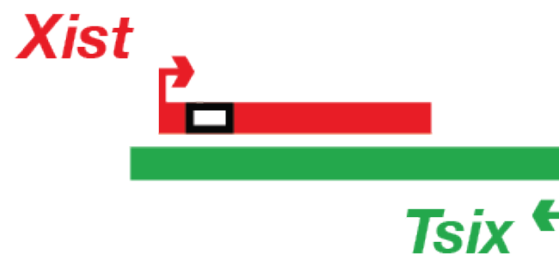

Jpx RNA activates Xist

In pre-XCI cells, CTCF (CCCTC-binding factor) represses Xist transcription. At the onset of XCI, Jpx RNA is upregulated, binds CTCF, and extricates CTCF from one Xist allele. CTCF is also an RNA-binding protein and is titrated away from the Xist promoter by Jpx RNA. Thus, Jpx activates Xist *in trans* by evicting CTCF.

However, a deletion on one X encompassing the Jpx locus showed a reduced XCI phenotype that was not rescued by a second Jpx copy introduced as a BAC transgene indicating only a cis-effect.

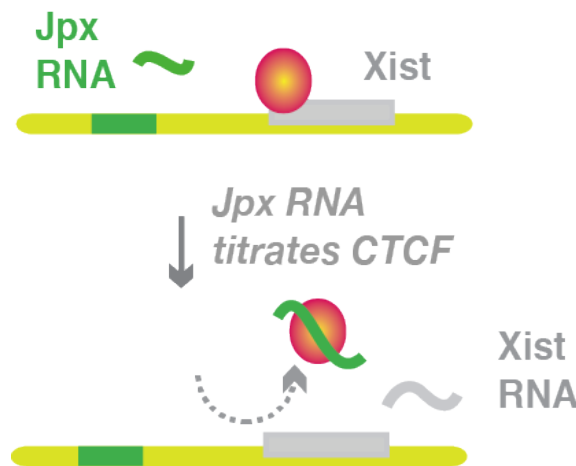

DOSAGE IS IMPORTANT: Role of imprinting in human disease

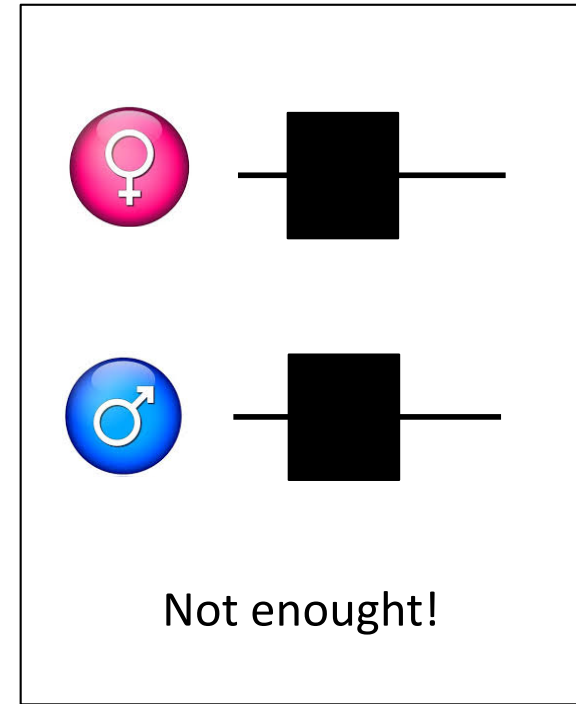
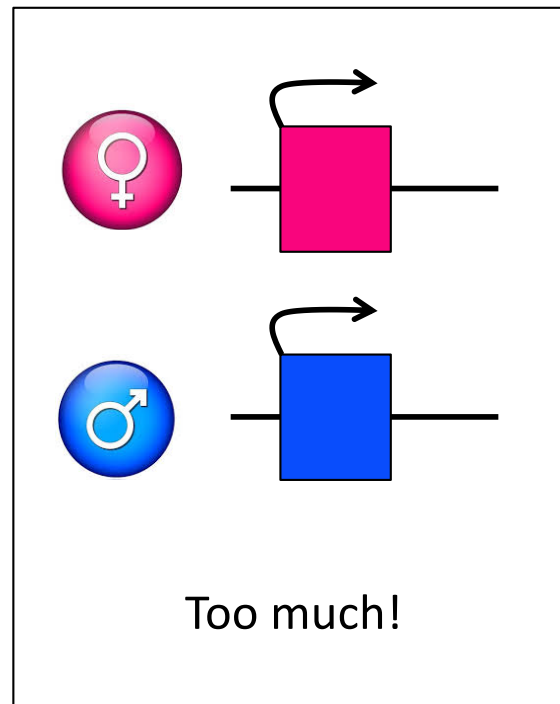
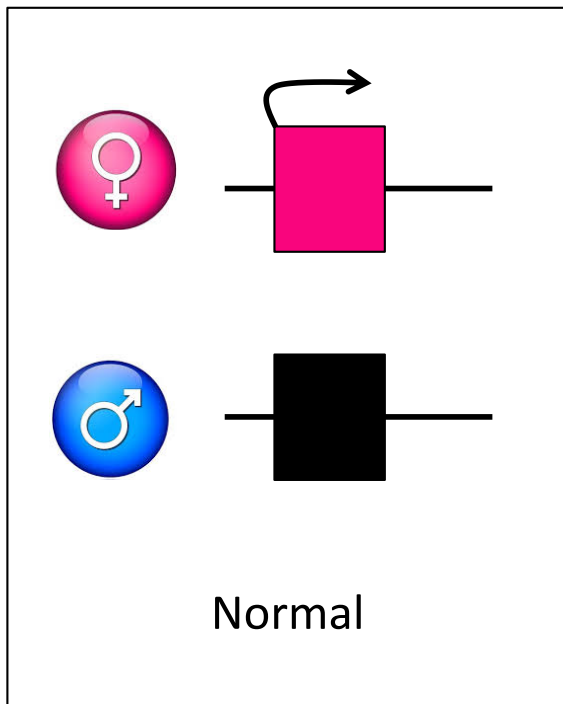

Role of imprinting in human disease

In humans, six imprinted regions have been consistently associated with disease. Many of these imprinting disorders cannot be explained by absence of a single gene product. In fact, the phenotypic diversity associated with each syndrome is consistent with absence of expression or mis-expression of multiple genes in the relevant region. Mis-expression can be due to:

- mutations in imprinted genes
- methylation defects at ICRs or other regulatory regions
- uniparental disomy (UPD), where an imprinted chromosomal region from one parent is replaced by the same chromosomal region from the other parent.

Two imprinting disorders caused by genetic or epigenetic changes in the same region can result in opposite growth phenotypes

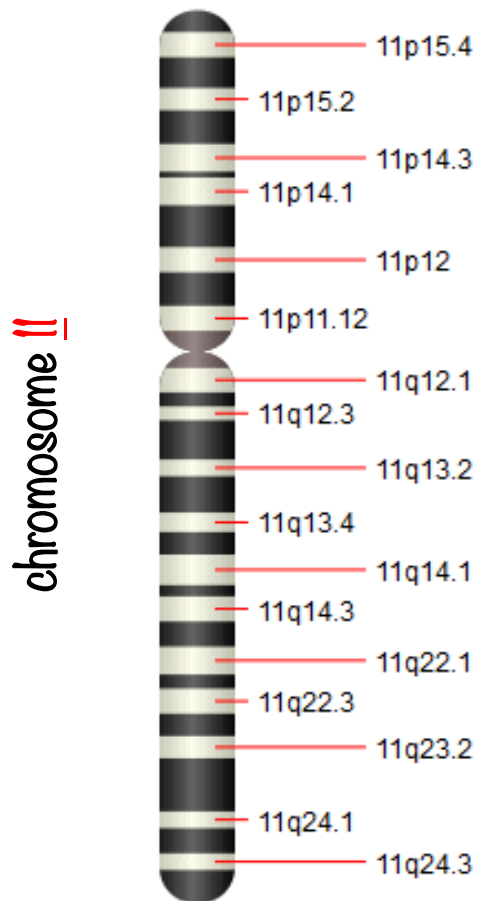

Russell-Silver syndrome (RSS), an **under-growth** disorder, is due to overexpression of maternal alleles and loss of paternal gene expression for chromosome 11p15.5. For the same region on **11p15.5**, overexpression of paternal alleles and loss of maternal gene expression leads to **Beckwith-Wiedemann syndrome (BWS)**, an **overgrowth** disorder. Of note, RSS can also be due to maternal UPD for chromosome 7.

BWS incidence: 1/13700 live births, characterized by both fetal and extraembryonic overgrowth

RSS is characterized by severe pre- and postnatal growth retardation including short stature with a normal head size, a triangular face with prominent forehead, and skeletal/limb asymmetry

These disorders demonstrate the opposing effects of imprinted genes on fetal and extraembryonic growth and development.

The chromosomal region 11p15.5

Silencing through in cis ncRNA transcription

Insulator model of Imprinting

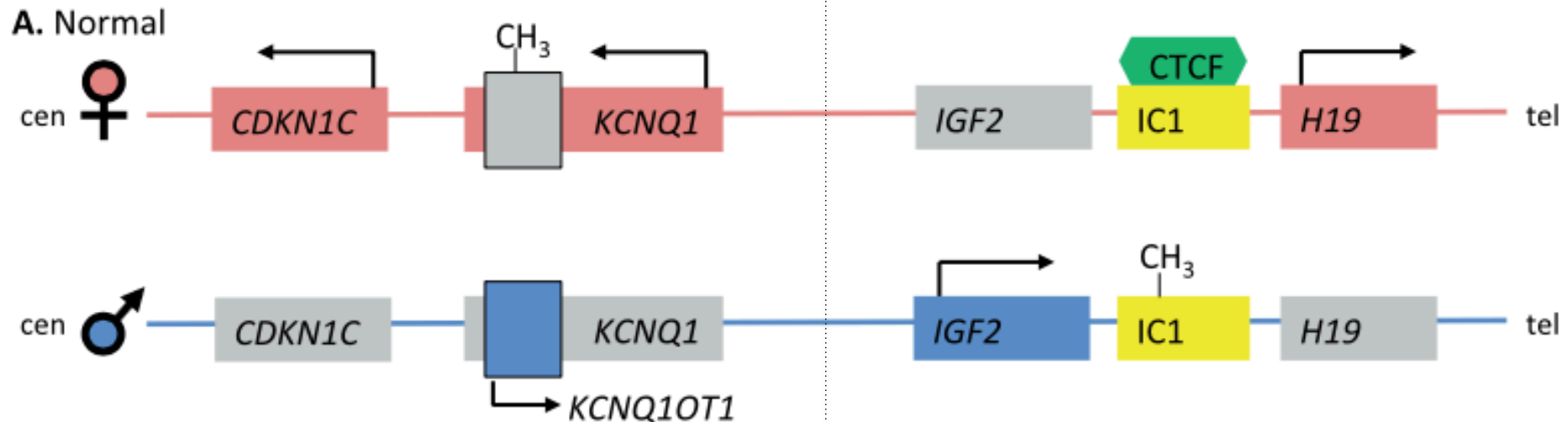

The chromosomal region 11p15.5 encodes several growth- promoting and -inhibiting factors and plays a key role in human growth and development. The region spans around 1 Mb and harbors two separate imprinting control regions (ICRs): The telomeric ICR1 (H19 DMR) is methylated on the paternal allele, whereas the centromeric ICR2 (KvDMR1; *KCNQ1OT1* DMR) is maternally methylated

Beckwith-Wiedemann syndrome

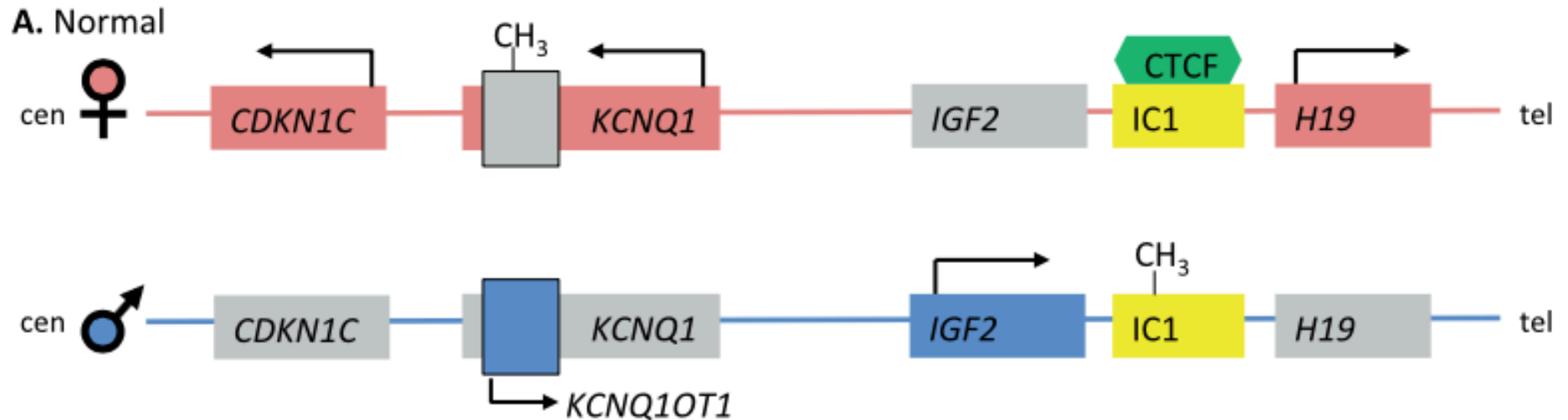

Normal imprinting and methylation at the 11p15 locus

B. BWS: Maternal IC2 LOM: 50%

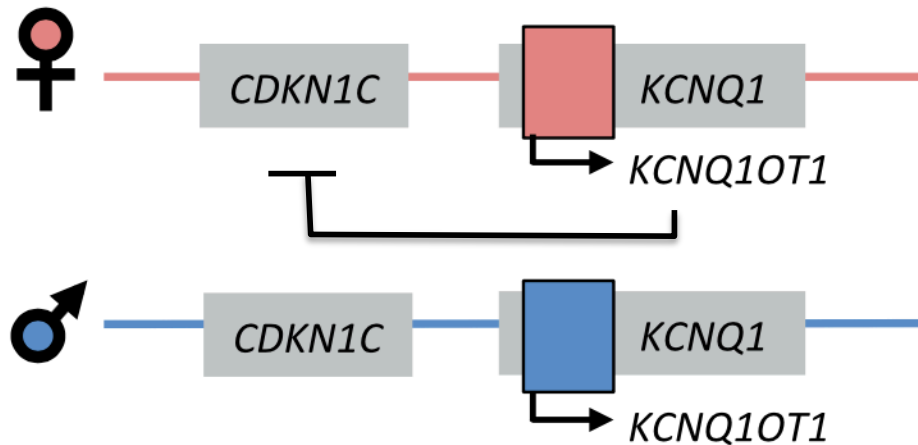

Hypomethylation at the human ICR (IC2) in the KCNQ1 locus leads to BWS

LOM: loss of methylation

CDKN1C is a cyclin-dependent kinase inhibitor of G1 cyclin complexes and acts to **negatively regulate cell growth and proliferation** leading to BWS overgrowth disorder

Beckwith-Wiedemann syndrome

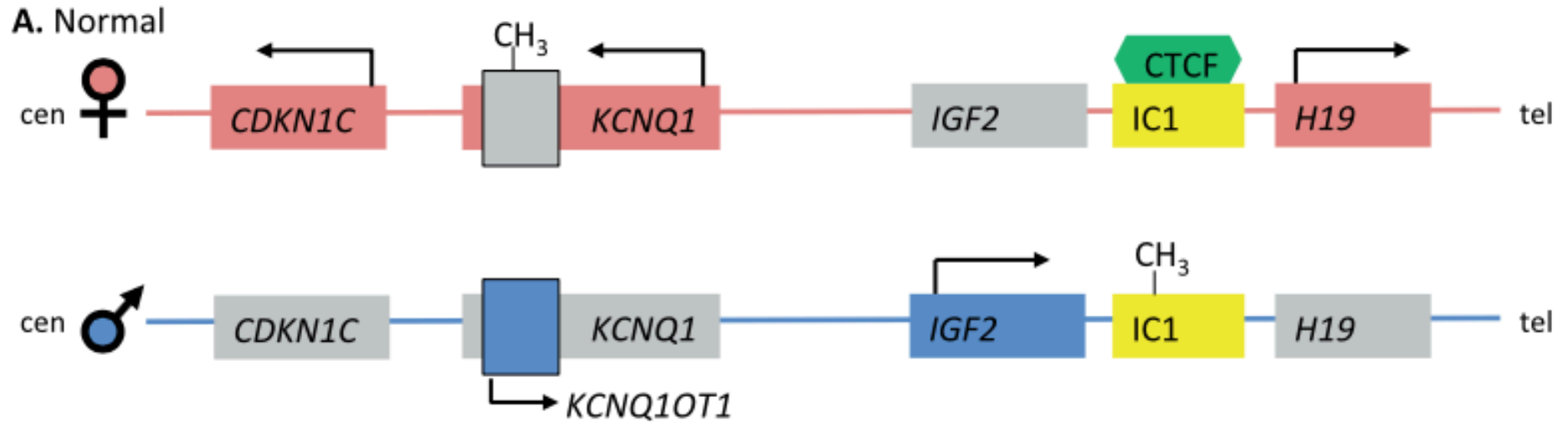

Normal imprinting and methylation at the 11p15 locus

Hypermethylation at IC1 in the H19/IGF2 locus leads to BWS.

GOM: gain of methylation

C. BWS: Maternal IC1 GOM: 5-7%

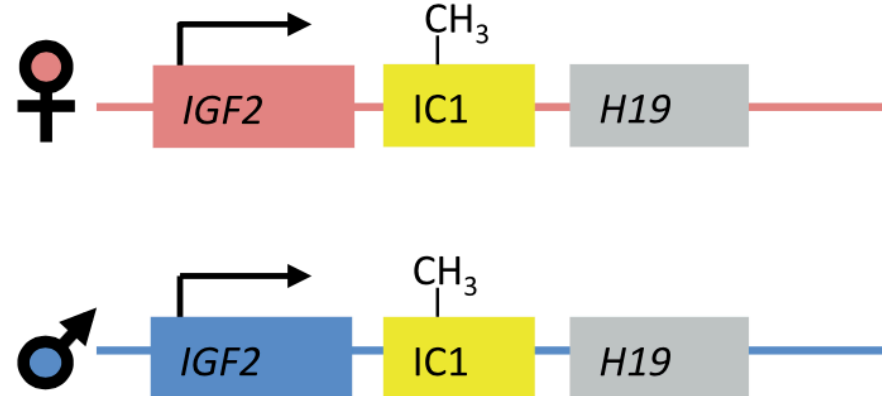

Overexpression of the growth factor *IGF2* and downregulation of *H19*, which encodes a ncRNA and microRNA (miR-675) implicated in growth suppression, with a developmental consequence of overgrowth

Beckwith-Wiedemann syndrome

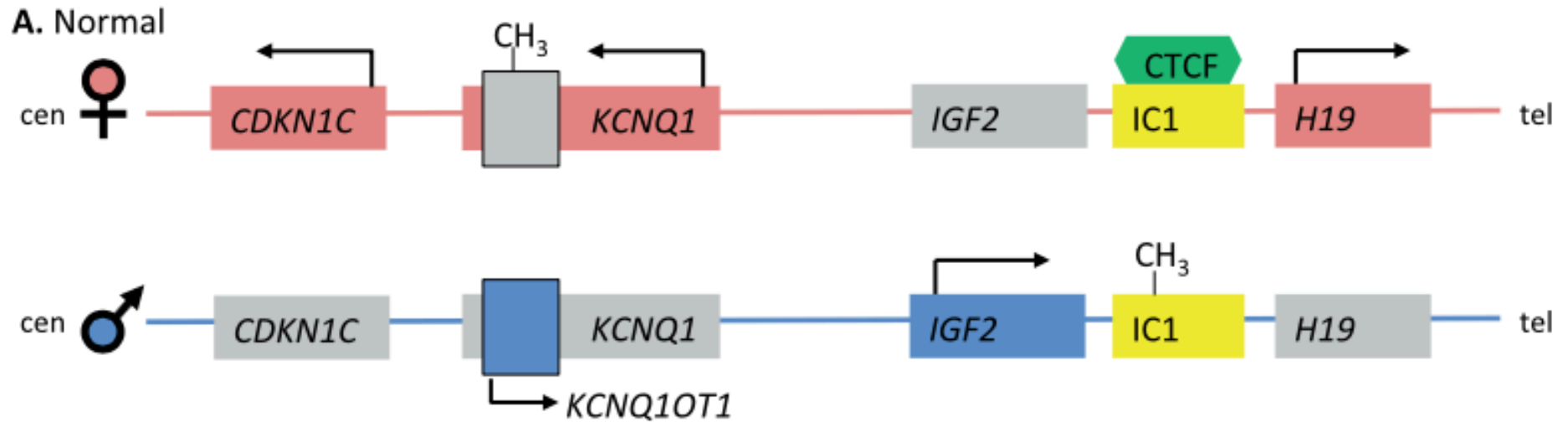

Normal imprinting and methylation at the 11p15 locus

D. BWS: Paternal 11p15 uniparental disomy: 20%

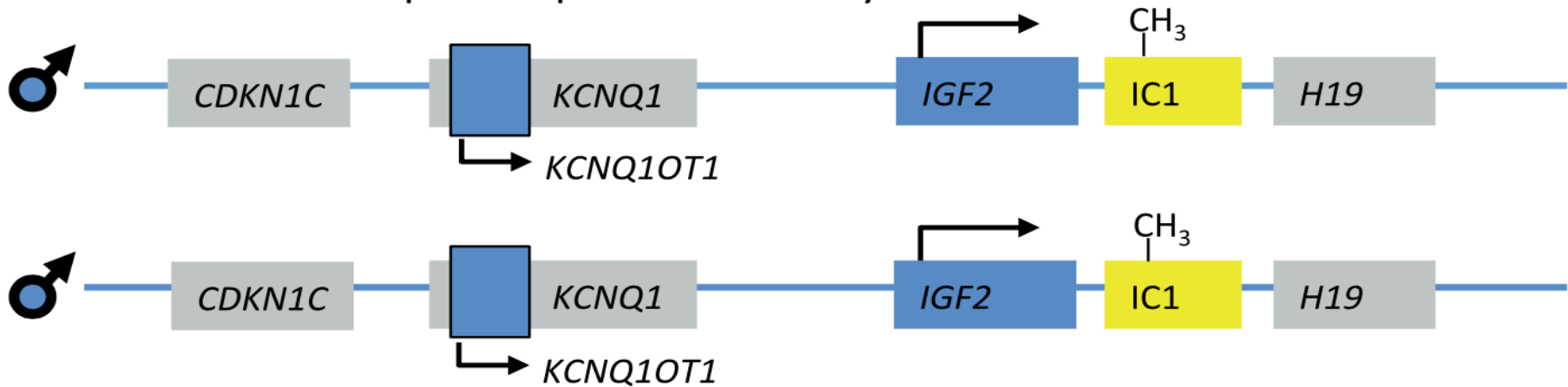

Paternal uniparental disomy leads to BWS.

Russell-Silver syndrome

A. Normal

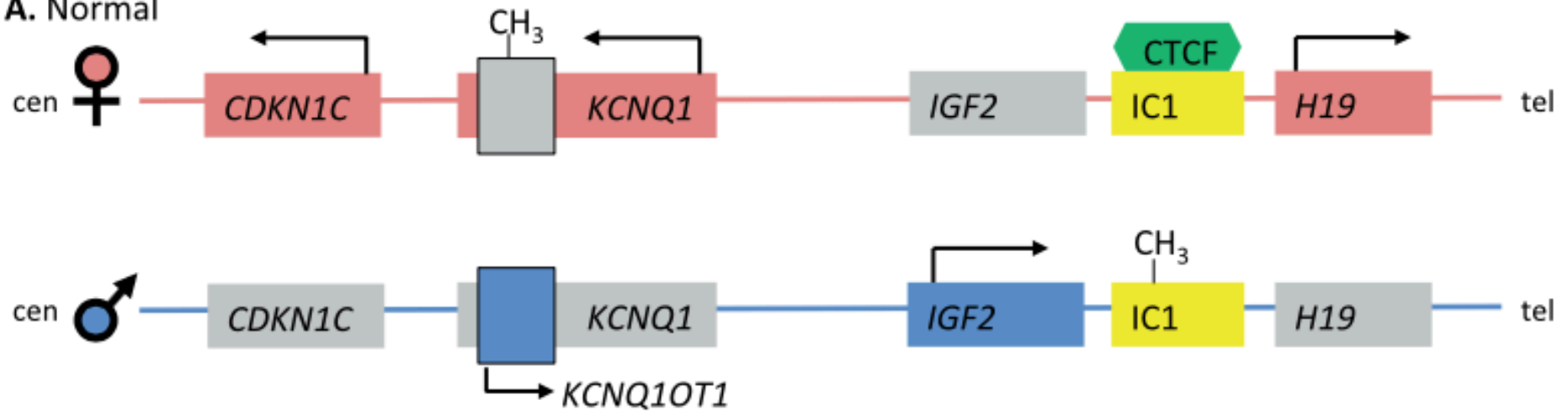

Normal imprinting and methylation at the 11p15 locus

F. RSS: Maternal 11p15 uniparental disomy

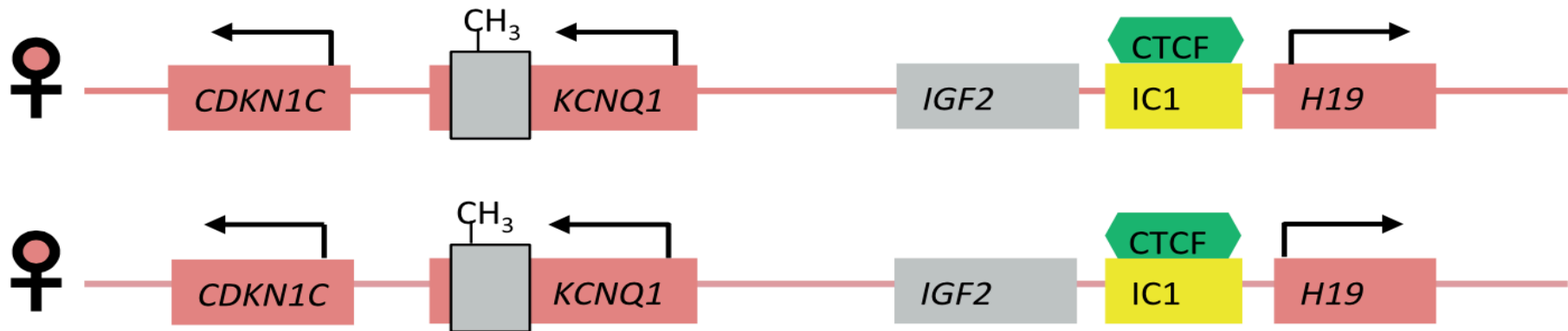

Maternal uniparental disomy leading to RSS (under-growth disorder the growth factor *IGF2* is downregulated) *CDKN1C*, that negatively regulate cell growth and proliferation, is overexpressed

Russell-Silver syndrome

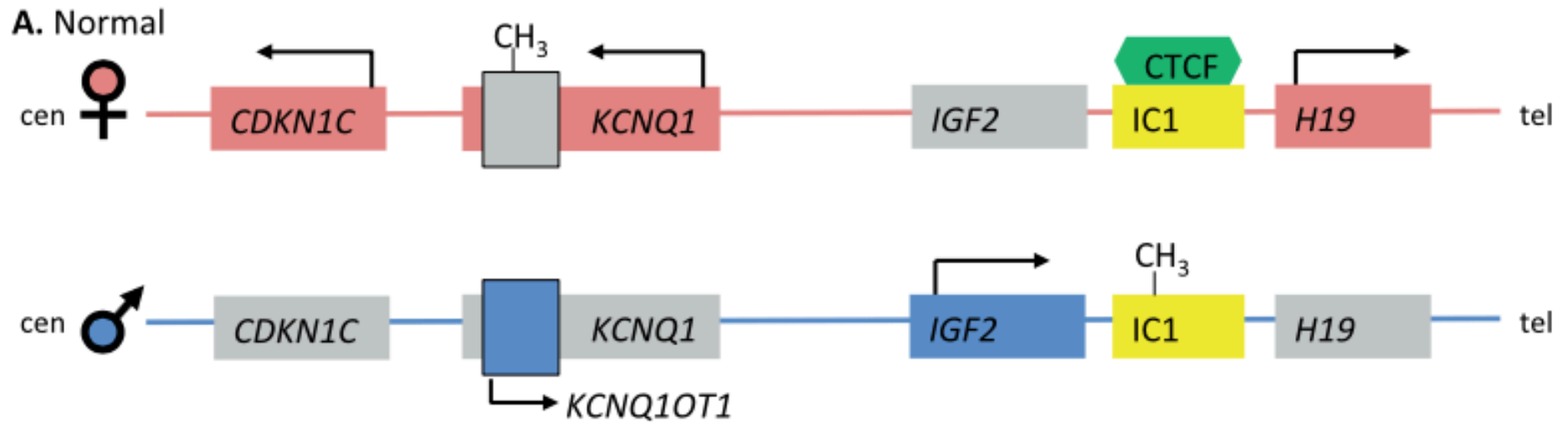

Normal imprinting and methylation at the 11p15 locus

E. RSS: Paternal IC1 LOM: 50%

