

Dopo i massimi sistemi ... la lista della spesa ☹️

- 1 – Questo è un corso di GEOMETRIA (descrittiva)
- 2 – RIPETO: questo è un corso di GEOMETRIA (descrittiva) chiaro?
- 3 – Questa materia, oggi più che mai, insegna a concepire e controllare la forma. In questo specifico corso la forma architettonica.
- 4 – In questo corso, pertanto voi dovrete acquisire o affinare questa capacità. In sede di esame dimostrerete questa maturità.
- 5 – Prenderemo confidenza con le forme geometriche semplici e complesse. Impareremo a riconoscerle, a concepirle, a nominarle, a rappresentarle (crearle, comunicarle), ad aggregarle (progetto della forma).
- 6 – Opereremo prevalentemente in ambito digitale.
- 7 – Acquisiremo la capacità critica di selezionare lo strumento digitale più appropriato per esprimerci al meglio con la forma.

Dopo i massimi sistemi ... la lista della spesa ☹

8 – Questo è un corso di ? Bravi! GEOMETRIA DESCRITTIVA

9 – Non sprecate tempo! Ogni attività che produrrete per questo corso, domandatevi se ha attinenza con la geometria. Se non sapete rispondere con certezza siete fuori strada, fuori tema. Non avete capito l'esercitazione, state sprecando tempo di studio.

10 – NON avrai altra fonte – sugli obiettivi del corso - all'infuori di me!

Facebook: Conoscere e comunicare

elearning2.uniroma1.it : Scienza della Rappresentazione II -GMValenti

Pwd: AA1718



questions are welcome

Gli insegnamenti afferenti l'area disciplinare del

DISEGNO

hanno l'obiettivo di far maturare negli allievi

le capacità critiche e le abilità pratiche

per **conoscere** e **comunicare**

l'architettura, la città e l'ambiente.

IL DISEGNO,

nell'accezione più attuale e generale del termine,
è il più potente **mezzo di comunicazione** a disposizione
dell'architetto, ma è anche e soprattutto
un **insostituibile ausilio alla conoscenza**:
attraverso di esso diamo forma al nostro pensiero, ne
comprendiamo le incertezze e,
in un processo ricorsivo di rappresentazione e osservazione,
lo ri-conosciamo e lo perfezioniamo

Oggetto e strumento del DISEGNO

è il modello nelle sue diverse manifestazioni.

Possiamo parlare di:

- **modelli tangibili** – modelli grafici (schizzo, rappresentazione grafiche codificate), digitali, fisici (maquette)
- **modelli “intangibili”**, definizione che può essere applicata ai modelli mentali e ideativi, mediante i quali si struttura la nostra conoscenza e che costituiscono un insostituibile supporto nella fase di espressione e comunicazione della genesi creativa.

Il corso di “**Scienza della Rappresentazione II**” focalizza il processo di analisi e interpretazione dello spazio architettonico.

L'approfondimento teorico nell'ambito della geometria descrittiva fornisce gli strumenti critici indispensabili per la comprensione e la rappresentazione dello spazio e delle forme architettoniche.

Sperimentando la genesì costruttiva delle forme luogo geometrico, così come le qualità espressive della forma libera, nonché le possibili aggregazioni\relazioni tra queste, lo studente affina il proprio senso critico in relazione all'analisi e alla composizione degli elementi che definiscono lo spazio e permettono, anche a livello progettuale, la prefigurazione delle sue trasformazioni.

ANALISI



PROGETTO E COMUNICAZIONE
DELLA FORMA LUOGO GEOMETRICO



PROGETTO E COMUNICAZIONE
DELLA FORMA LIBERA



INTRODUZIONE

analisi GEOMETRICA dell'architettura

storica ? NO!

funzionale? NO!

strutturale? NO!

distributiva? NO!

della sostenibilità? NO!

fattibilità economica? NO!

!!! GEOMETRICA !!!

analisi GEOMETRICA dell'architettura ...

... CHE SIGNIFICA ?

Descrivere (ipotizzare)
la GENESI della forma architettonica.

N.B. La GENESI NON il prodotto finale.

Genesi? Nascita, creazione, origine
il graduale concretarsi e organizzarsi (**GEOMETRICO**)
di un'opera d'arte nella mente dell'artista.

Come procedere ?

Identificare la QUALITÀ GEOMETRICA prevalente : segno\forma\trasformazione originale.

Descriverla RIGOROSAMENTE nella sua definizione\evoluzione

- Testualmente.
- Con un diagramma di flusso (algoritmo).
- Con dei grafici sintetici esemplificativi.

Identificare le QUALITÀ GEOMETRICHE secondarie e terziarie

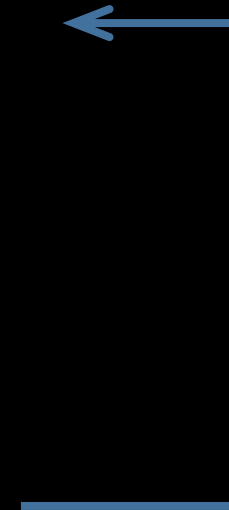

- Con un diagramma di flusso (algoritmo).

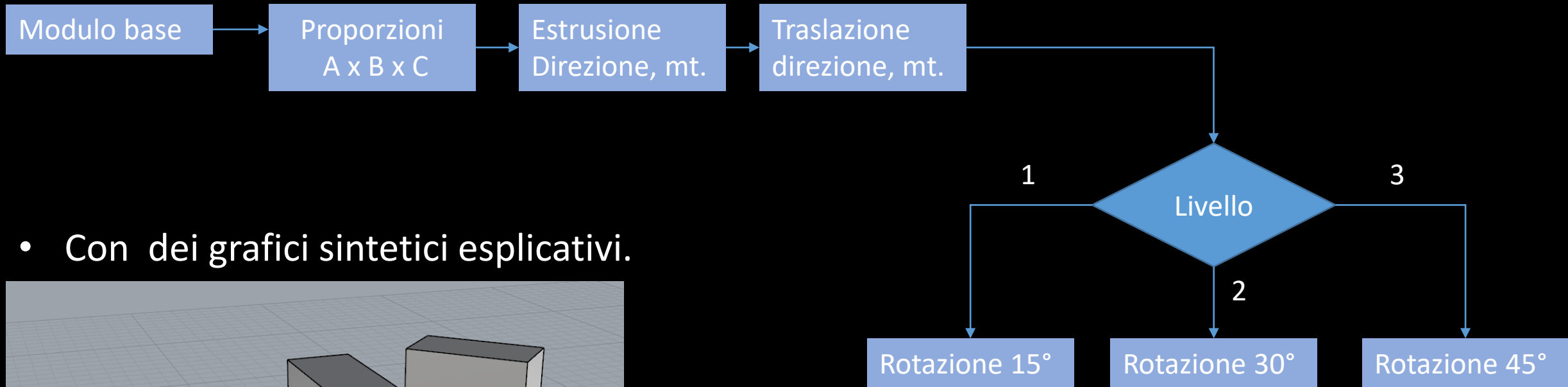

- Con dei grafici sintetici esplicativi.

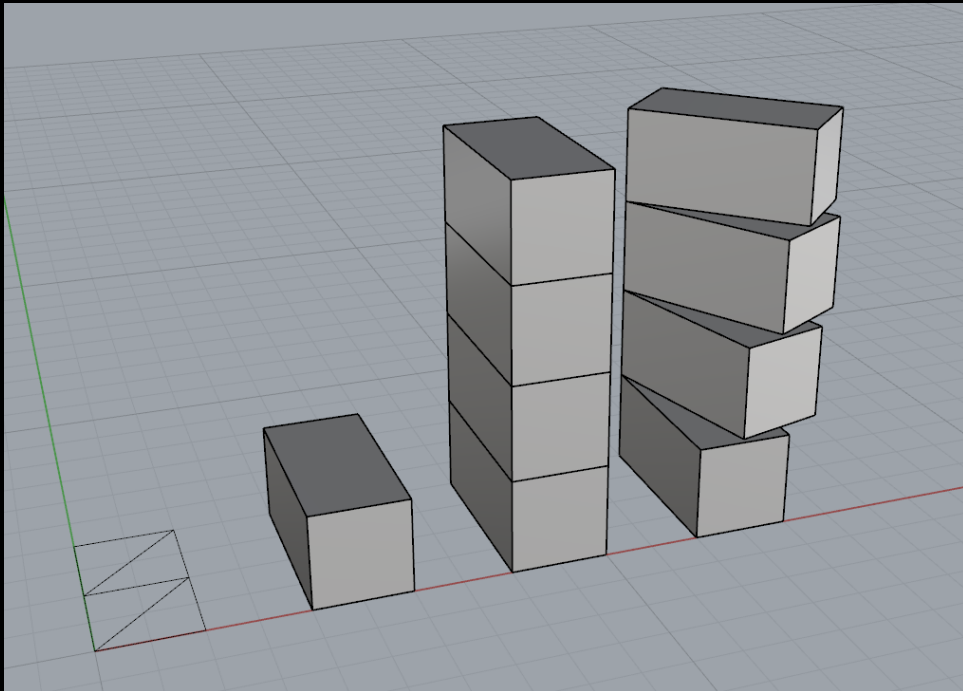

LA QUALITÀ ... invariante.

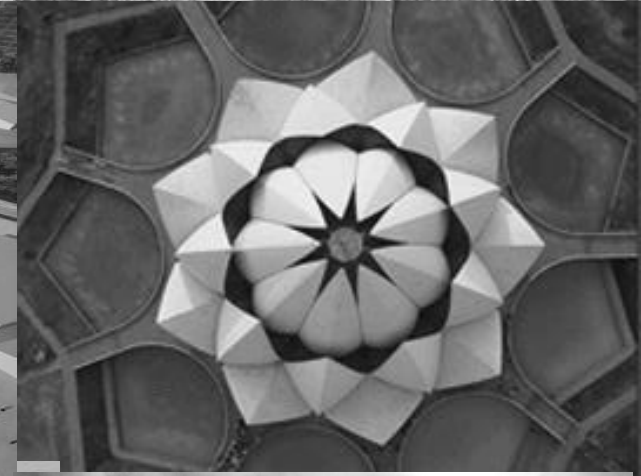
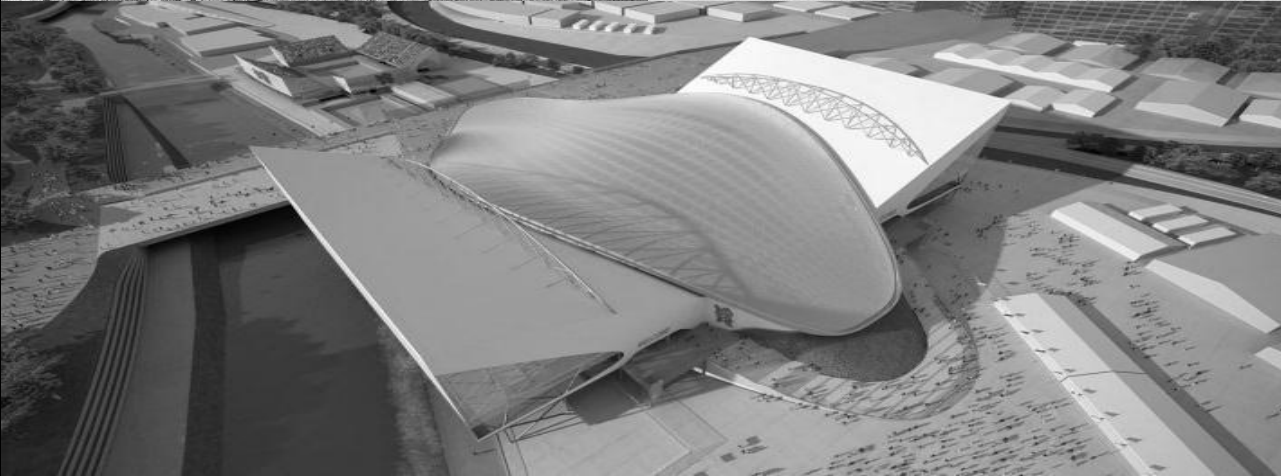

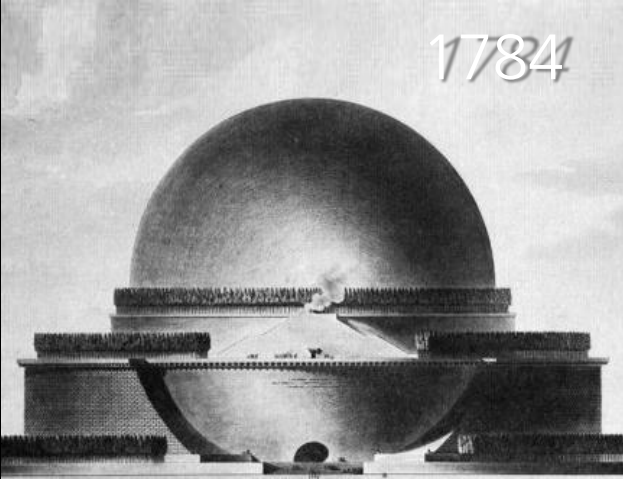

1784

CENOTAFIO Étienne-Louis Boullée

NATIONAL ASSEMBLY Louis Kahn



1989

LOUVRE Ieoh Ming Pei



1992

REICHSTAG Foster

GRANDE ARCHE J.Otto von Spreckelsen



1962

1985

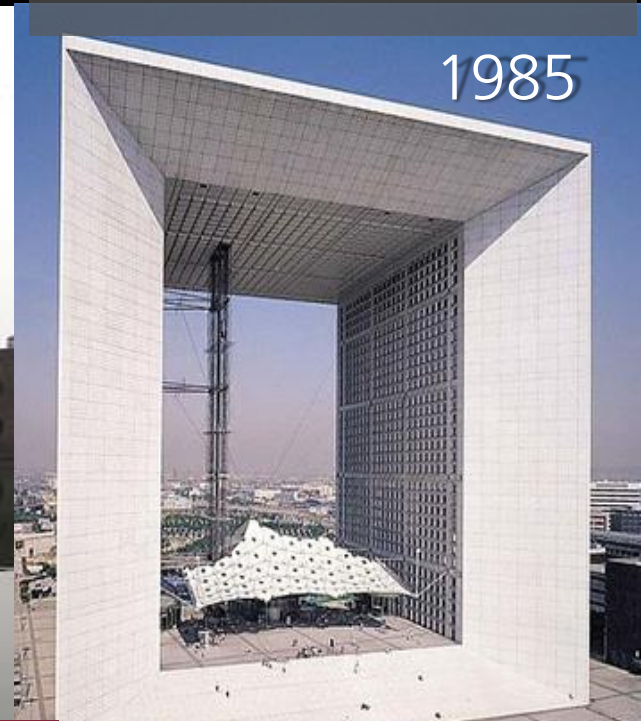

1985

FORMA PURA

1975



IVRY SUR SEINE Jean Renaudie

1978



BANK OF GEORGIA Chakhava ,Jalaghania

THE INTERLACE OMA

1999





ROTAZIONE



HABITAT 67 Moshe Safdie



RAMONT HOUSING Zvi Hecker



KUBUSWONINGEN Piet Blom

CAPSULE TOWER Kisho Kurokawa

BUMPS Sako Architects

ECO PODS Höweler + Yoon



1972



2009



2009

MODULARITÀ

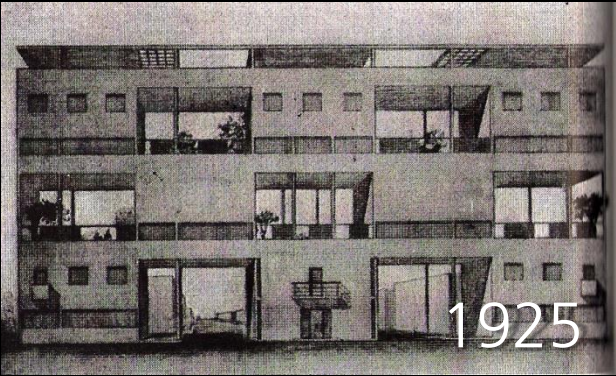

1925

IMMEUBLES VILLA Le Corbusier



2009

CELOSIA MVRDV



2011

VIVIENDAS EMV Amann Canovas Maruri

KANCHANJUNGA 2 Charles Correa



1970



1994

PIENO VUOTO



1952

UNITÉ D'HABITATION NANTES Le Corbusier



2007

ACADEMY OF ART Wang Shu



2010

SUGAMO BANK Emanuelle Moureaux

KINDERGARTEN IN JIADING Deshaus

ZOLLVEREIN SCHOOL SANAA



2011



2006

SERIE



2012

RESIDENZE Zon-e Architectos



2010

RESIDENZE Zon-e Architectos



2004

RESIDENZE Zon-e Architectos



AGGETTO



1997

WoZoco Apartments MVRDV 2



2004

SOCIAL HOUSING, CARABACHEL- Dosmasunos



2007

RESIDENZE VIA DOBERDÒ - Arkpabi



AGGETTO

2010



BALANCING BARN MVRDV



PASS MUSEUM Verner Tschol

ART MUSEUM Coop Himmelb(l)au

CENTRO MULTIFUNZIONALE Barbosa Guimarães

2010



2008



2012



SBALZO

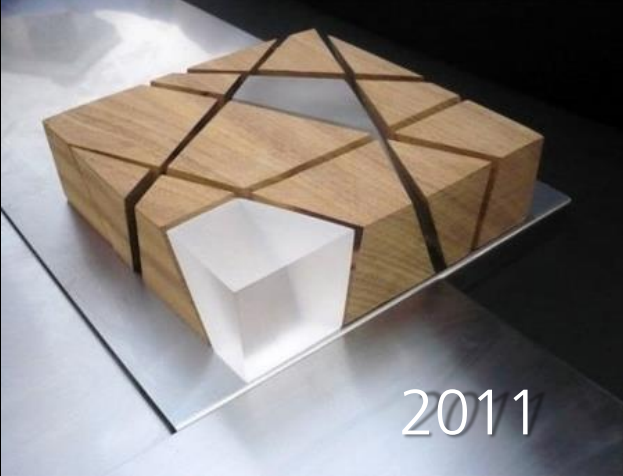

2011

PADIGLIONE ITALIANO G.Imbrighi

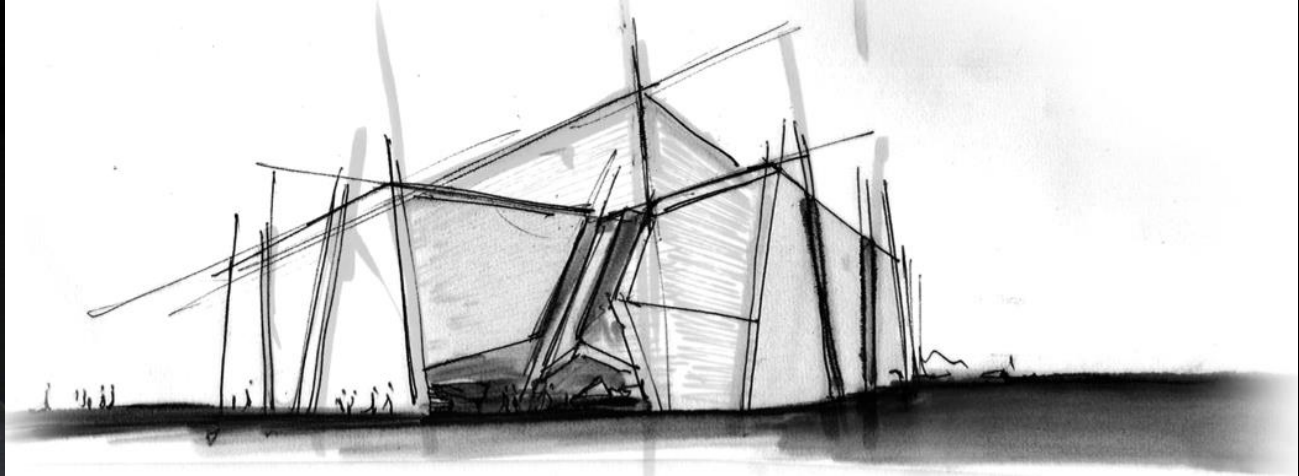

SUNWELL MUSE T.Tamagami



2008

TAGLIO



1999

HET BAKEN KCAPArchitects



2005

CASA DA MUSICA R. Koolhaas



2011

K HOUSE D.I.G. Architects



TAGLIO

2009



BEIRUT TERRACE Herzog e De Meuron

VELES E VENTS David Chipperfield

SUGAMO BANK Emanuelle Moureaux

2006



2011



STRATIFICAZIONE

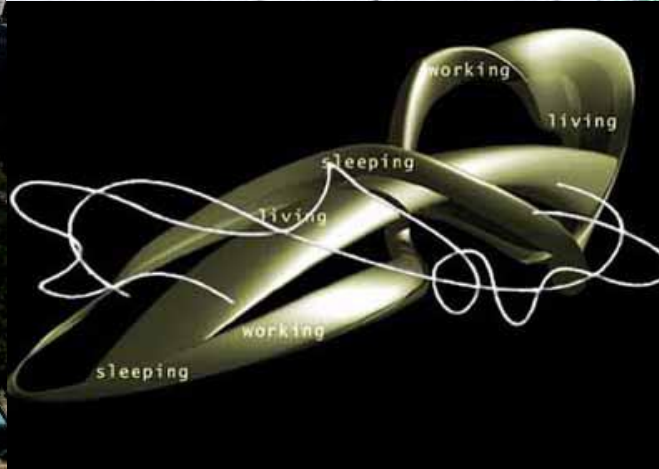
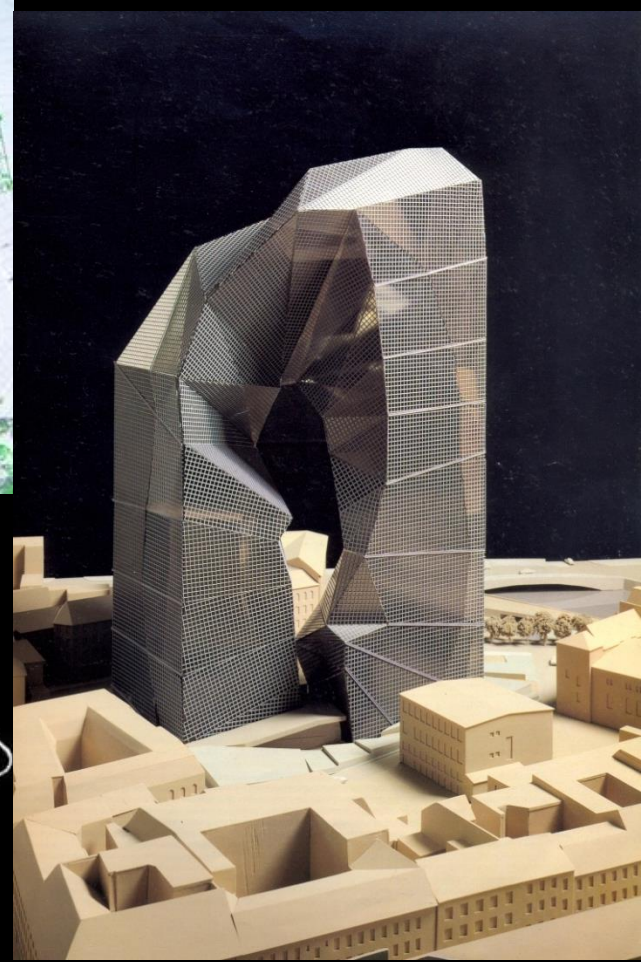

NASTRO



DISEGNO SULLA FORMA

LA QUALITÀ ... invariante.

... ma non ora!

2010



CLINIC Frank Gehry

2012



ADMIRANT SHOPPING Fuxas

MUSEUM OF TRANSPORT Zaha Hadid

MERCATO Miralles Tagliabue

2004



2005



DEFORMAZIONE



ESPLOSIONE

1936



JOHNSON WAX FL Wright

2012



PUBLIC SERVICE HALL Fuxas

2000

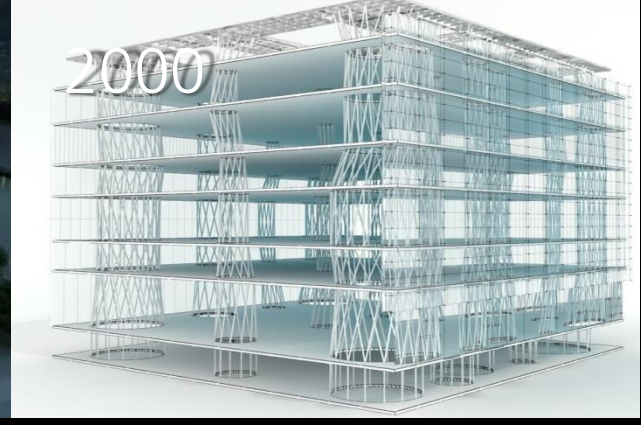

MEDIATHEQUE Toio Ito

CHIESA AUTOSTRADA Giovanni Michelucci

TOD'S BUILDING Toio Ito

1964



2004



NATURA



2012

EVOLO SKYSCRAPER Eric Vergne



2000

SON O HOUSE Nox



2012

BIONIC TOWER Team Lava

D-TOWER Nox

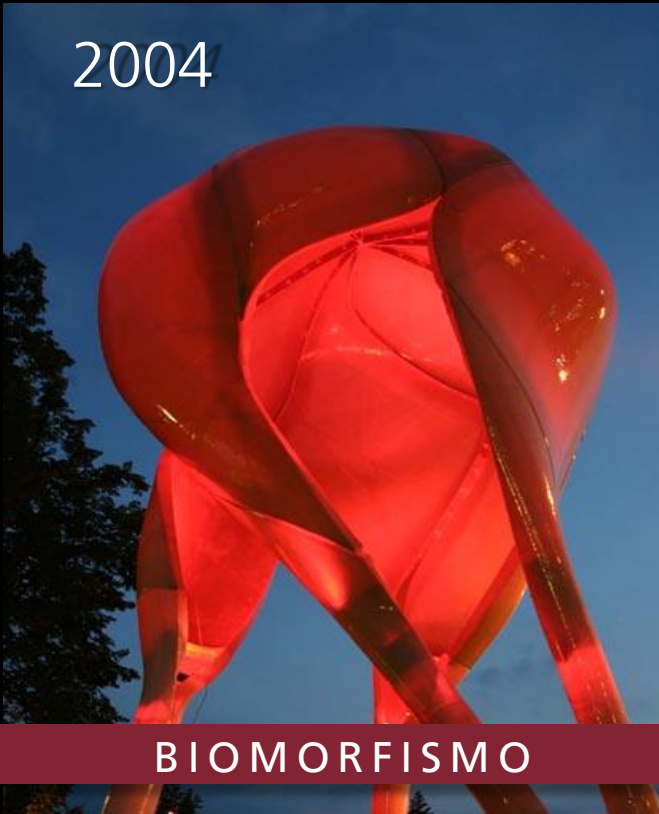
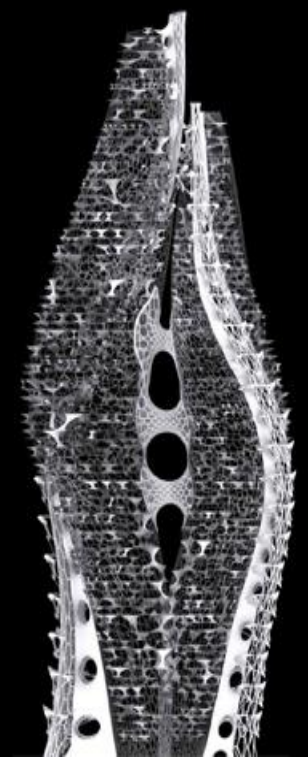

2004

BIOMORFISMO

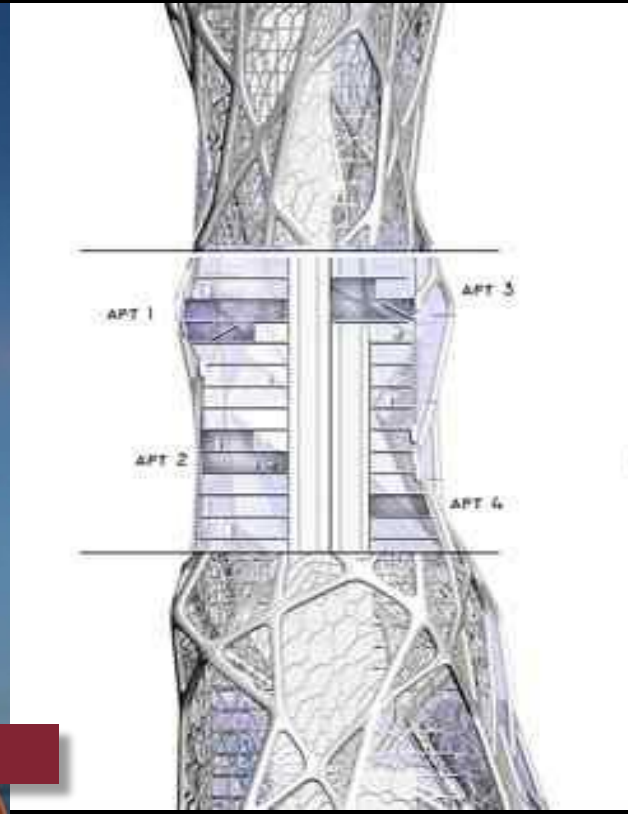

INDICAZIONI PROCEDURALI

Analisi geometrica dell'architettura

1. LE FONTI
2. IL METODO
3. IL RIGORE, LA VERIFICA
4. LA COMPLETEZZA
5. L'ALGORITMO

LE FONTI

- Fotografie →
 - Documenti
 - Disegni
 - Modelli
 - Visita
- provenienza certificata
 - risoluzione (pixel o dpi) adeguata allo studio
 - quantità sufficiente a documentare senza ambiguità la qualità esaminata
 - verifica delle incongruenze (architetture sosia e fotoritocchi)

LE FONTI

- Immagini
 - Documenti 
 - Disegni
 - Modelli
 - Visita
- possibilmente dell'autore dell'opera architettonica
 - se di altri autori verificare quanto scritto (doppia attenzione)
 - riportare la frase
 - riportare la fonte
 - associare alla frase lo schema\modello che ne dimostra il significato

LE FONTI

- Immagini
 - Documenti
 - Disegni 
 - Modelli
 - Visita
- solo dell'autore
 - risoluzione adeguata
 - verificare l'unità di misura
 - verificare la scala
 - verificare la presenza di deformazioni introdotte in fase di acquisizione\riproduzione

LE FONTI

- Immagini
 - Documenti
 - Disegni
 - Modelli
 - Visita
- 
- solo dell'autore
 - verificare l'unità di misura
 - verificare la scala
 - verificare la coerenza con le immagini a disposizione
 - comprendere il grado di dettaglio del modello

LE FONTI

- Immagini
- Documenti
- Disegni
- Modelli
- Visita



- auspicabile ma difficile
- produrre foto personali (? modalità)
- misurare prima con gli occhi e poi ... con il resto

DOVE CERCARE ?

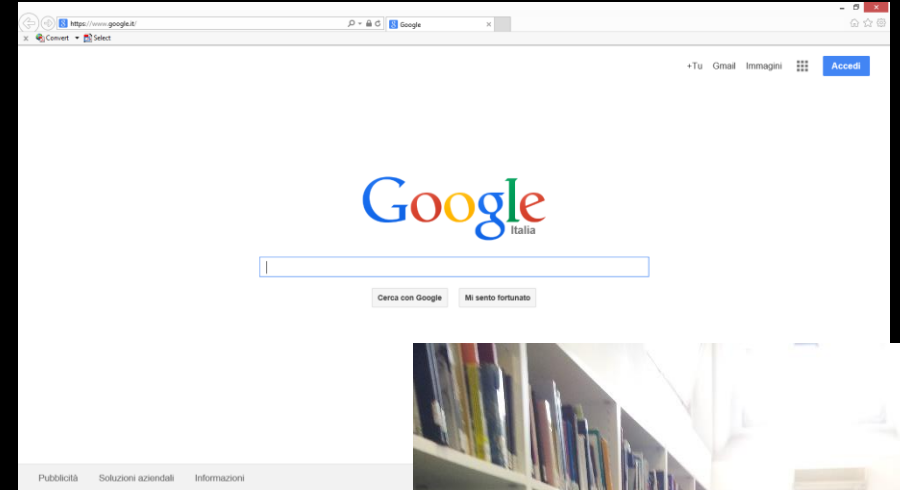

METODO

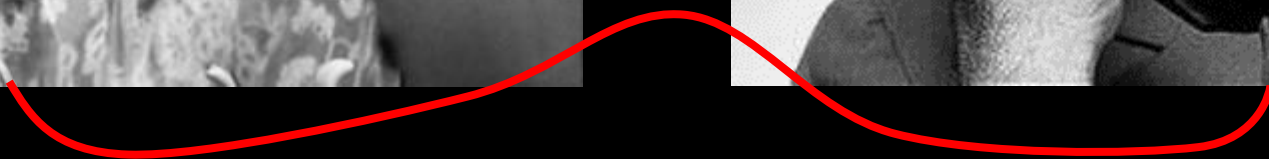

1

Rettangolo
 $L=A, P=2A$

Estrusione
 $H= 2/3A$

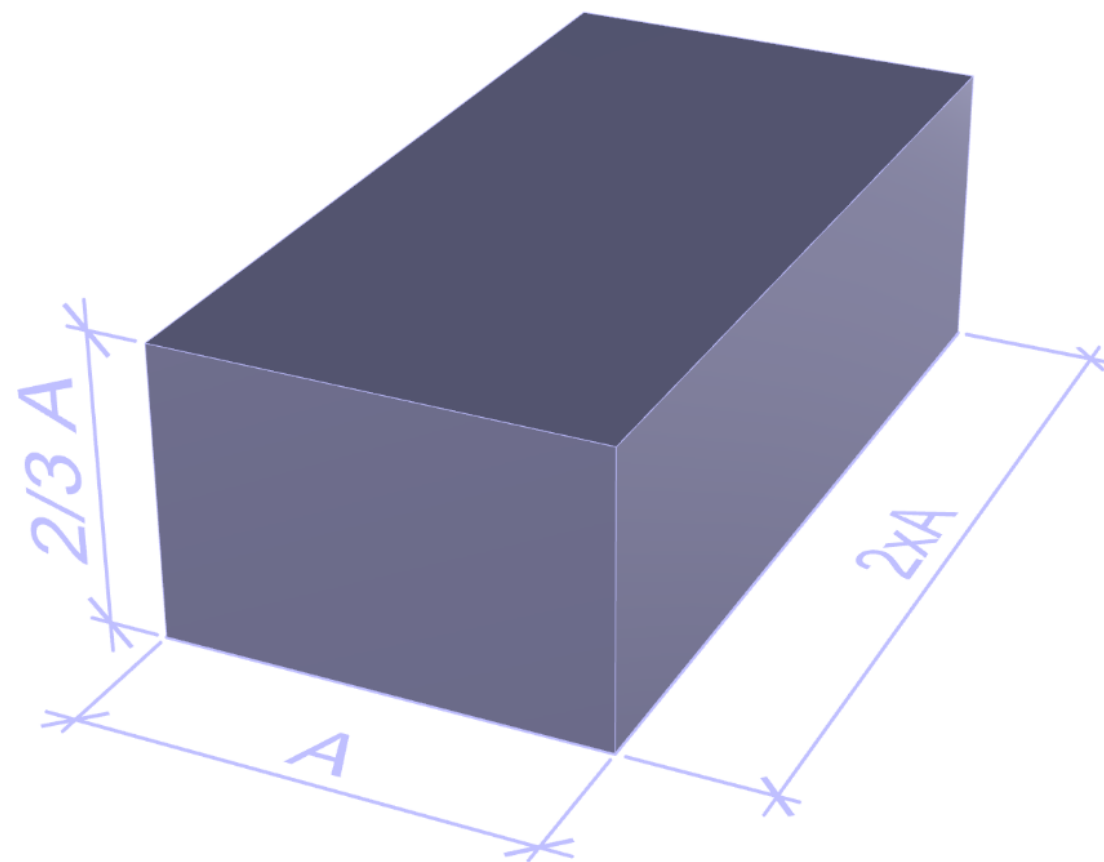
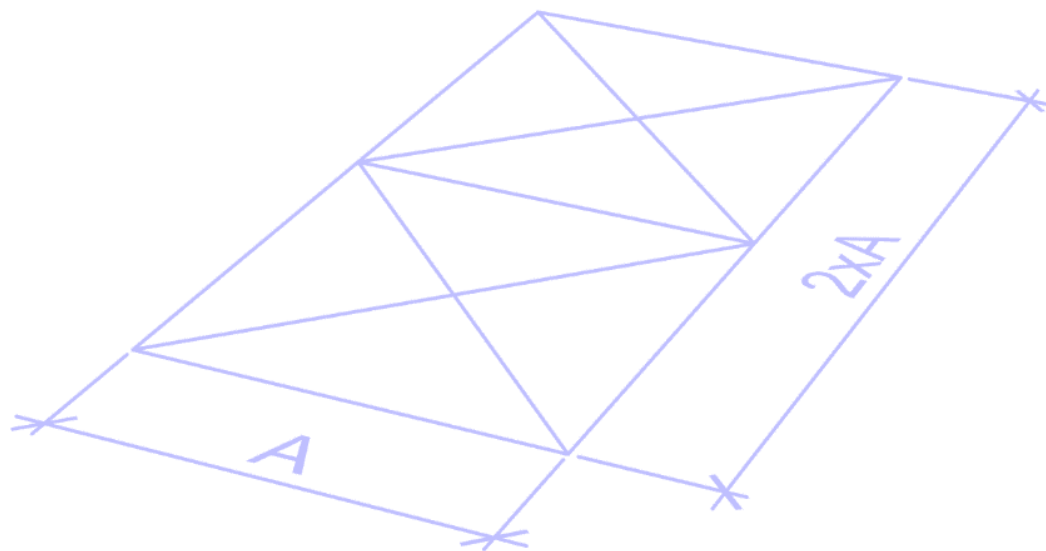

1

Rettangolo
 $L=A, P=2A$

Estrusione
 $H= 2/3A$

SERIE
rip $X= 6$; d $X= A$

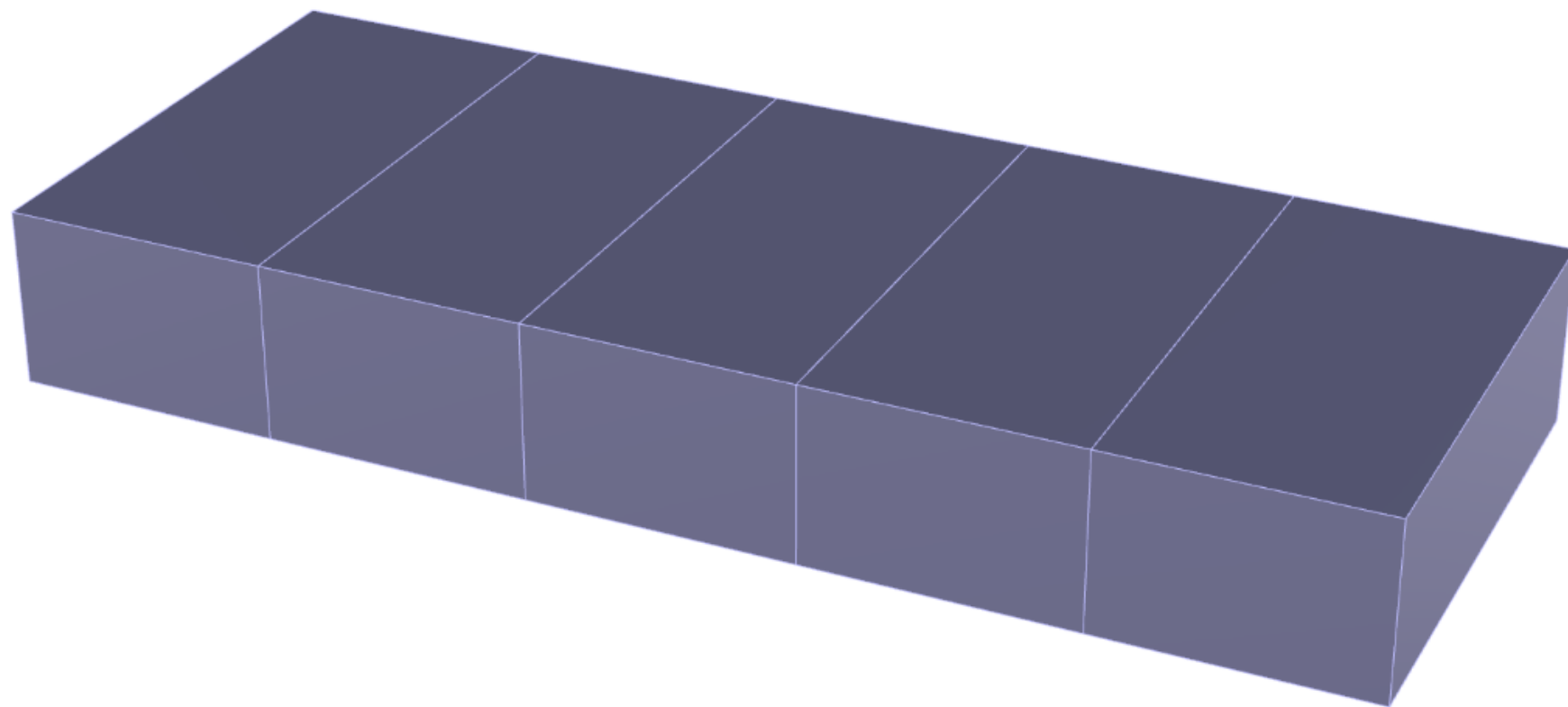

1

Rettangolo
 $L=A, P=2A$

Estrusione
 $H= 2/3A$

SERIE
rip $X= 6$; d $X= A + 2/3 A$

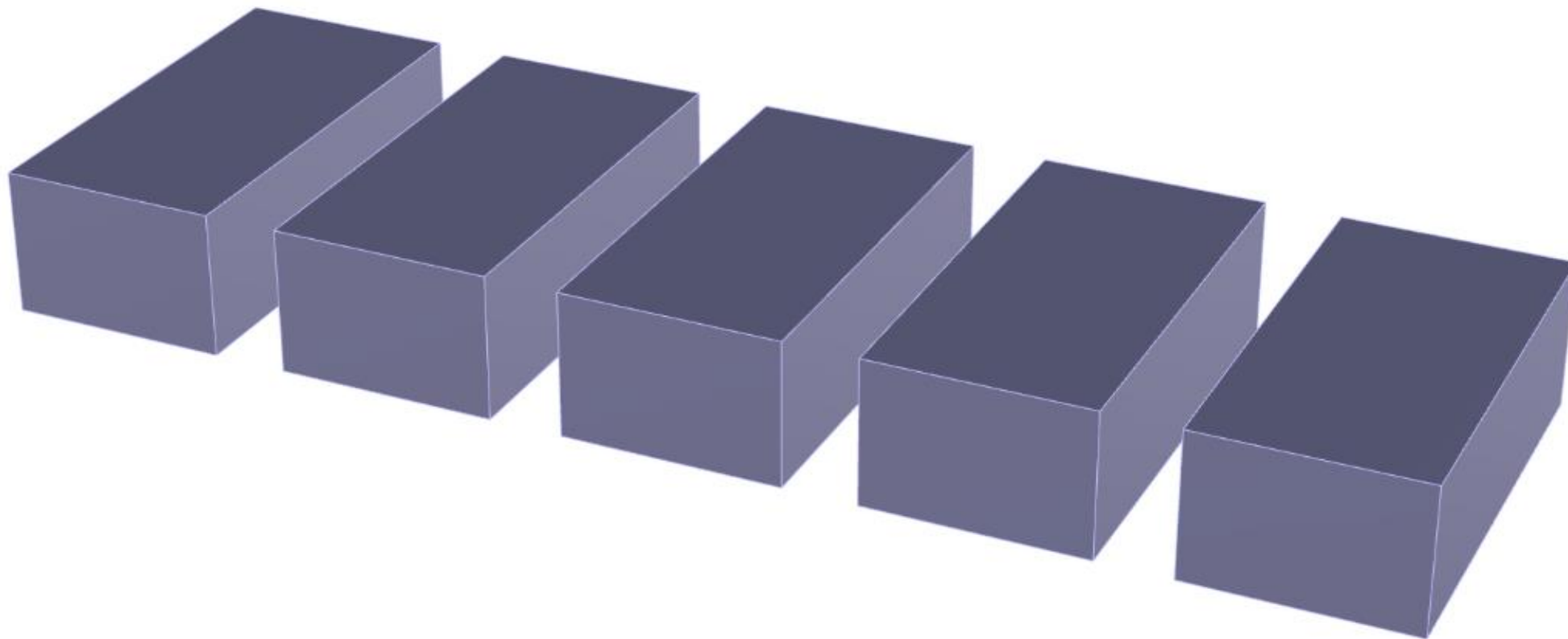

1

Rettangolo
 $L=A, P=2A$

Estrusione
 $H= 2/3A$

SERIE
rip $X= 6$; d $X= A + 2/3 A$
rip $Y = 3$ d $Y = 2/3 A$

