

Dinamica del citoscheletro nelle cellule del sistema immunitario

Il citoscheletro nei leucociti

Table 1 | **Cytoskeletal polymers in leukocytes**

Protein subunit	Polymer growth	Bound nucleotide	Regulation of polymer length	Associated proteins	Motor proteins
Microfilaments					
Monomeric (G) actin	Nucleation (both sides)	ATP	Treadmilling Phosphate-based ageing and debranching Dynamic instability Post-translational modifications	Nucleators: ARP2/3 and formins Capping proteins: CAPZ and gelsolin Anti-capping: Ena/Mena/VASP Crosslinkers and lateral association: ABP1 G-actin interacting proteins: profilin and thymosin- β 4 Cytolinkers: α -actinin and ERM proteins Severing: ADF/cofilin	Myosins
Microtubules					
α/β tubulin heterodimer	Nucleation (one side)	GTP	Treadmilling Phosphate-based polymer instability	Lateral association: MAPs, tau and ensconsin Plus end: CLIP170 and EB1	Dyneins and kinesins
Intermediate filaments					
Various proteins (mainly vimentin)	Not known (probably nucleation)	None	Fixed length	Cytolinkers: plectin	No

- **Microfilaments** composed of **filamentous F-actin**, control **membrane plasticity**, including cytoskeleton-propelled **deformation** and **protrusion** and **cell motility**.
- **Microtubules** are long polymers formed by **α/β tubulin heterodimers**, mediate primarily leukocyte **division** and have a role in leukocyte **migration** and **effector functions**.
- **Intermediate filaments**, mostly composed of **vimentin**, are involved in structural support.

Biopolimeri filamentosi del citoscheletro

Microfilamenti

Strands made of spherical protein subunits called actins

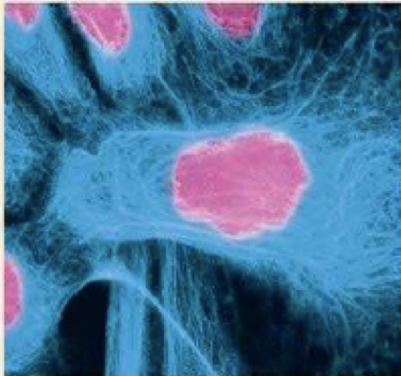
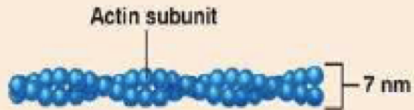

Microfilaments form the blue network surrounding the pink nucleus in this photo.

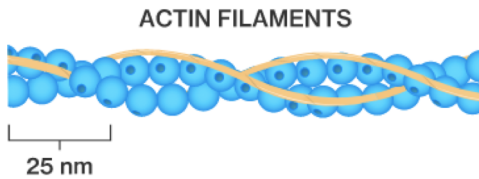

- Polymer of actin monomers, 7 nm in diameter
- Globular protein arranged in a helix
- Major contractile component

Microtubuli

Hollow tubes of spherical protein subunits called tubulins

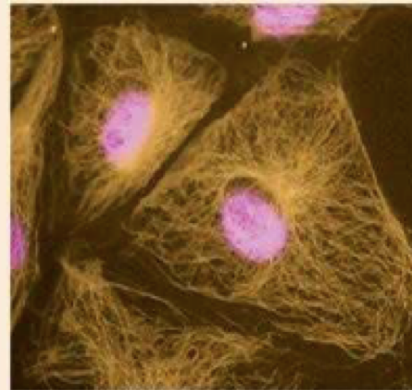
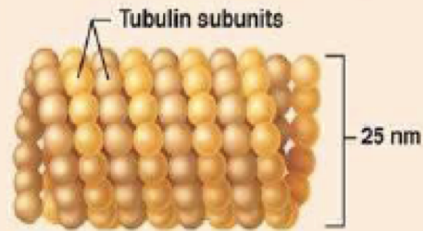

Microtubules appear as gold networks surrounding the cells' pink nuclei in this photo.

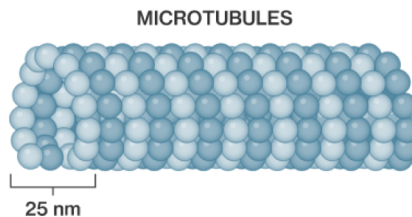

- Filament of tubulin monomers, 25 nm in diameter
- Play a role in cell structure, organization, mitosis, and movement

Filamenti intermedi

Tough, insoluble protein fibers constructed like woven ropes composed of tetramer (4) fibrils

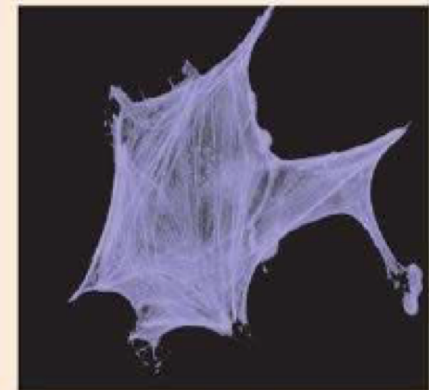
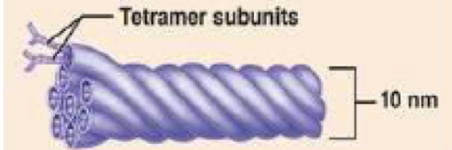

Intermediate filaments form the purple batlike network in this photo.

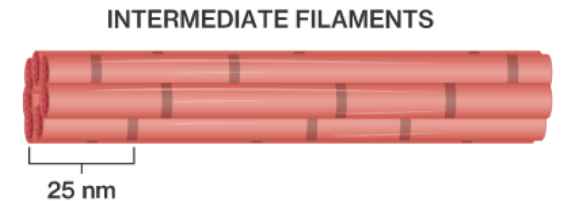

- Cytoskeletal filament, 8-12 nm in diameter
- Structural protein in eukaryotic cells

Citoscheletro e reclutamento dei leucociti dal sangue ai tessuti

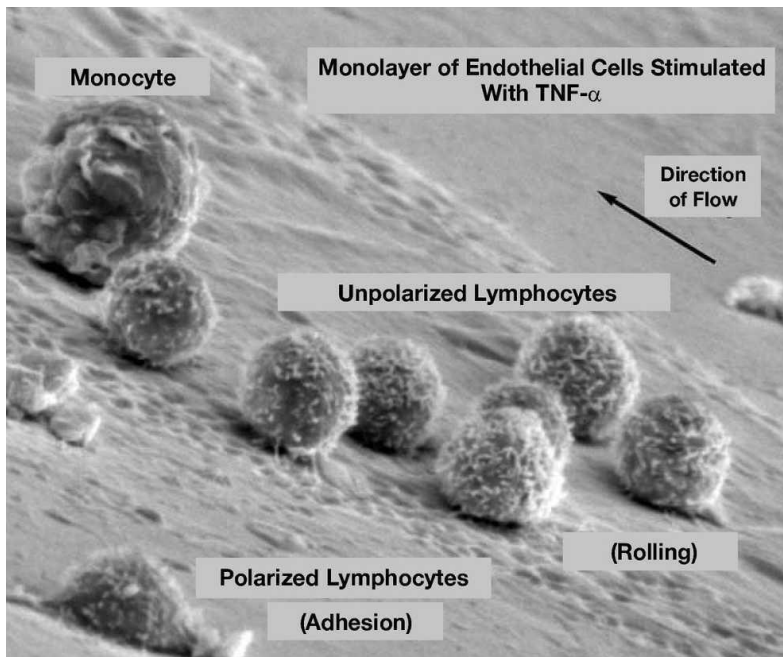
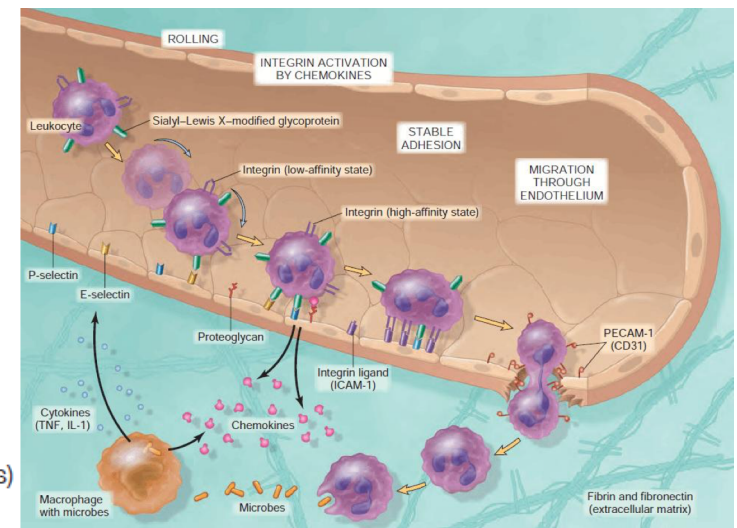
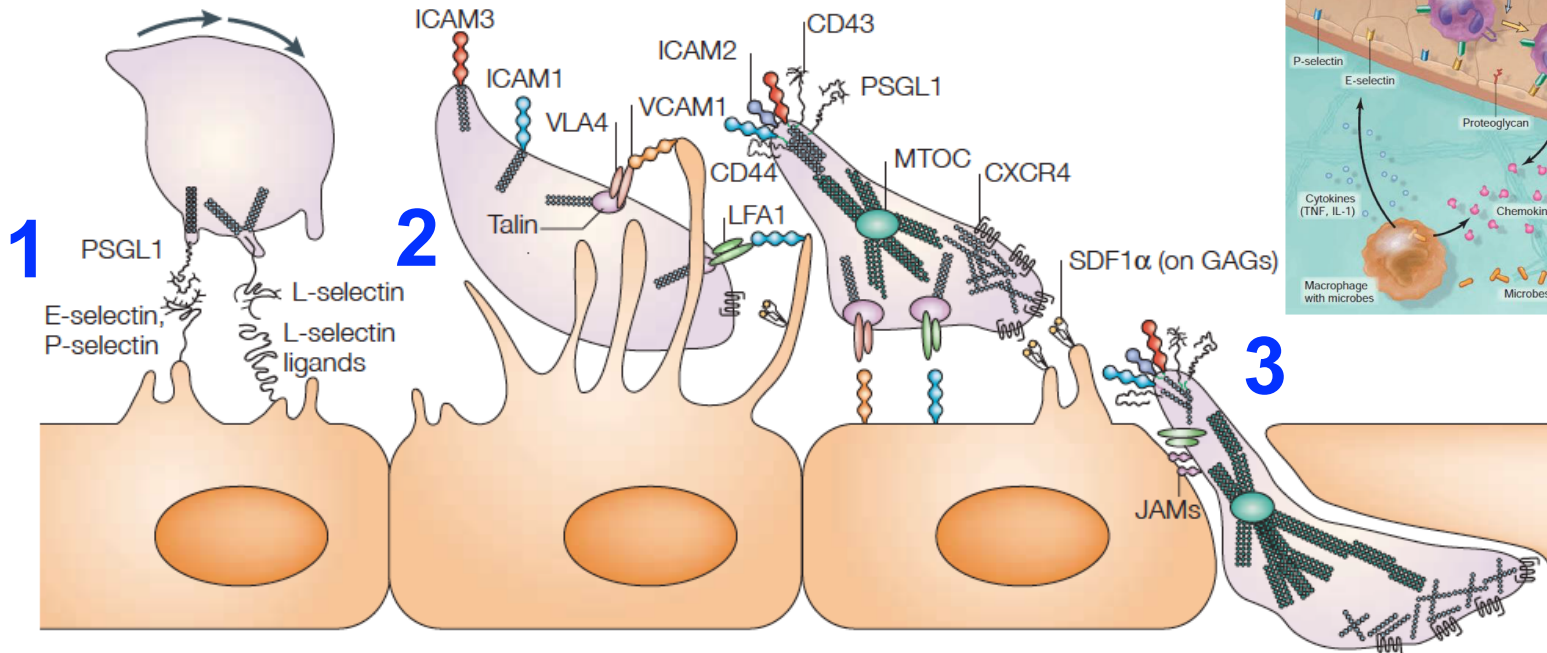

1. Adesione blanda mediata dalle **selectine**
2. Adesione stretta mediata dalle **integrine**
3. Attraversamento strato endoteliale seguendo il gradiente **chemochinico**

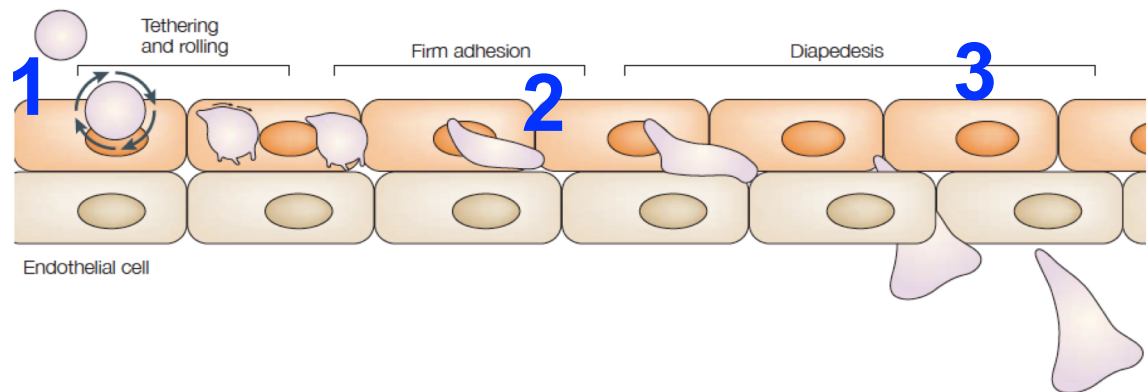

Citoscheletro e chemotassi

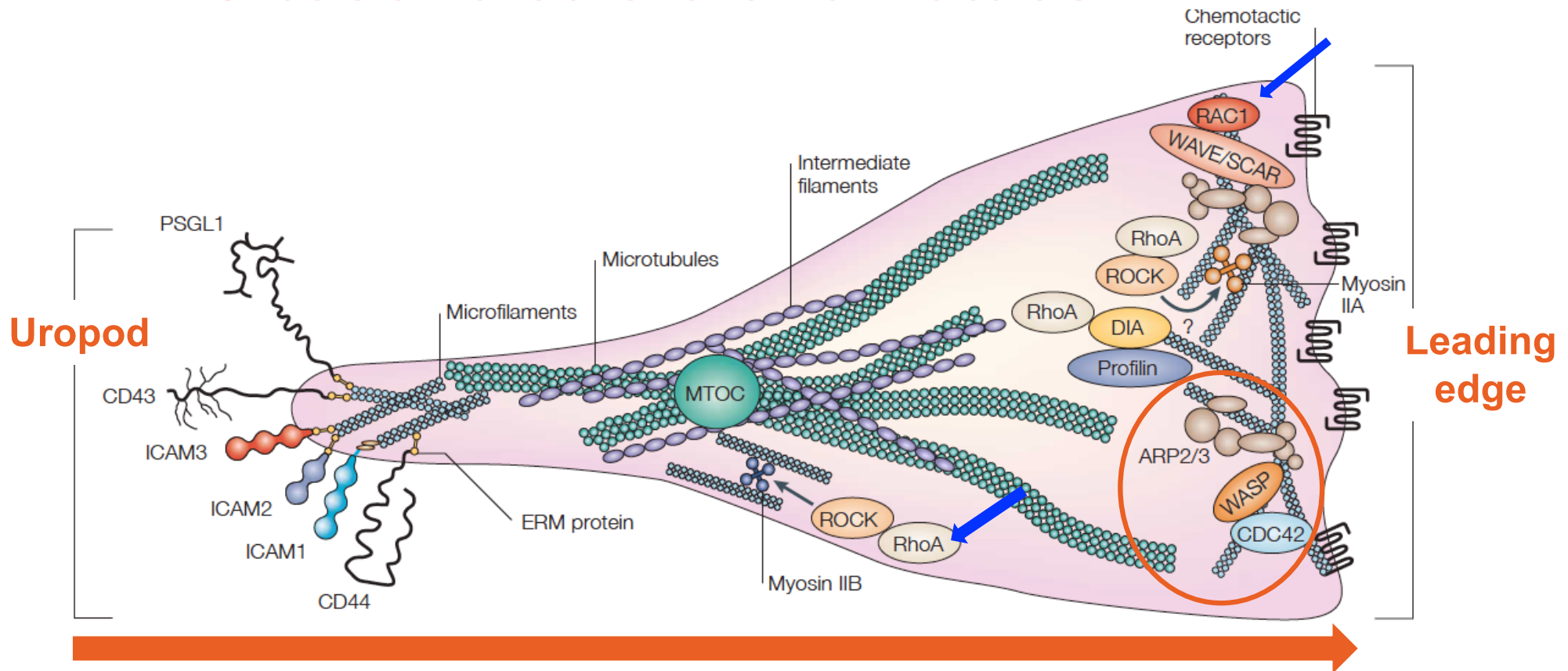

1. Polimerizzazione dell'actina (F-actina) indotta dai recettori per chemochine nel leading edge dove si concentrano tutti i recettori delle chemochine.
2. Riorganizzazione dei microtubuli con polarizzazione MTOC per la formazione del leading edge e dell'uropodo.
3. Nell'uropodo si concentrano le molecole di adesione con F-actina per il contatto leucocita-endotelio.

Citoscheletro dei linfociti T e sinapsi immunologica

Sinapsi immunologica o SMAC=supramolecular activation cluster = regione di contatto tra linfociti T ed APC

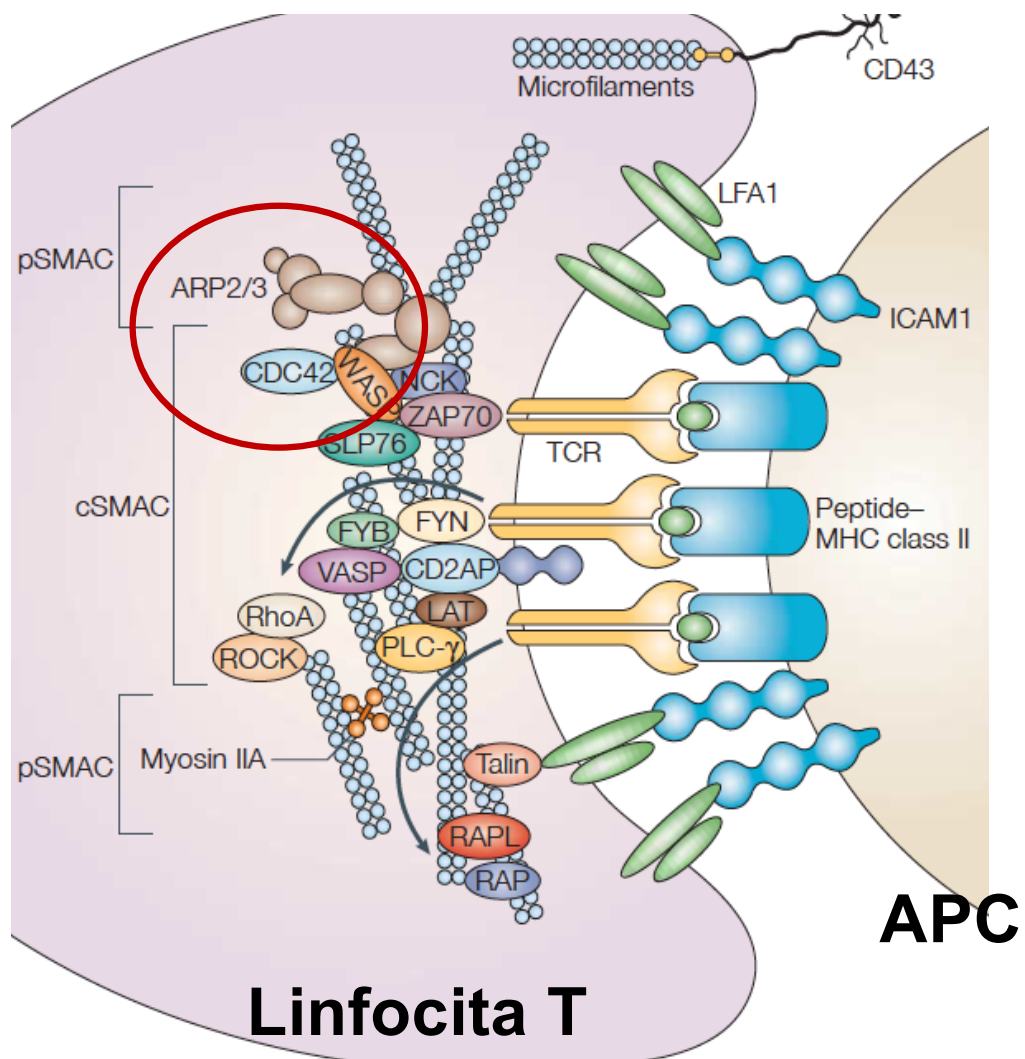

1. Adesione tra linfocita T e cellula presentante l'antigene (APC) mediata dal riconoscimento del complesso MHC/peptide da parte del TCR.
2. Il segnale del TCR induce una profonda riorganizzazione del citoscheletro di actina.
3. I TCR, co-recettori (CD4 o CD8), molecole costimolatorie (CD28), molecole di segnalazione e raft lipidici si concentrano nella zona centrale di contatto T:APC (**cSMAC in rosso nella figura in basso**)
4. L'integrina **LFA1** si lega ad **ICAM1** sull'APC localizzandosi nella zona periferica (**pSMAC in verde nella figura in basso**)

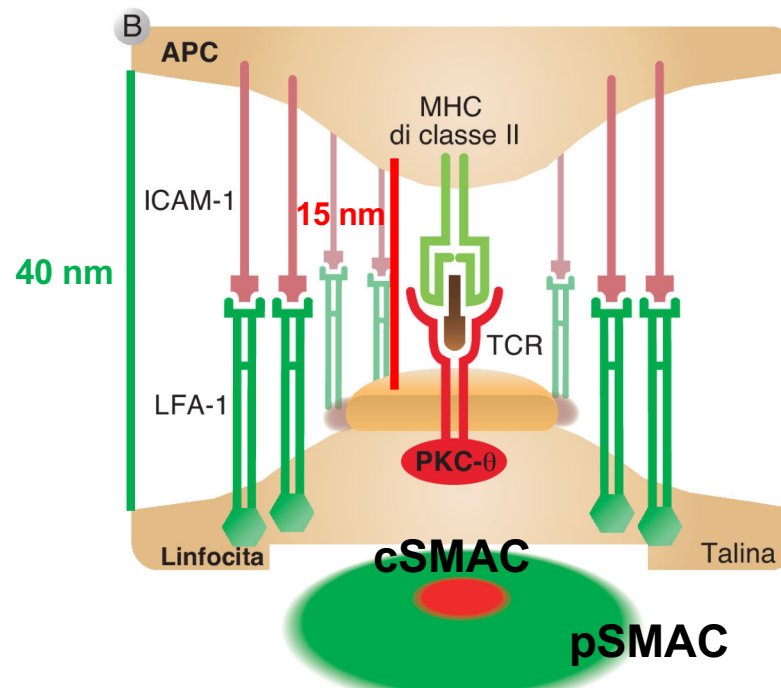

La sinapsi immunologica

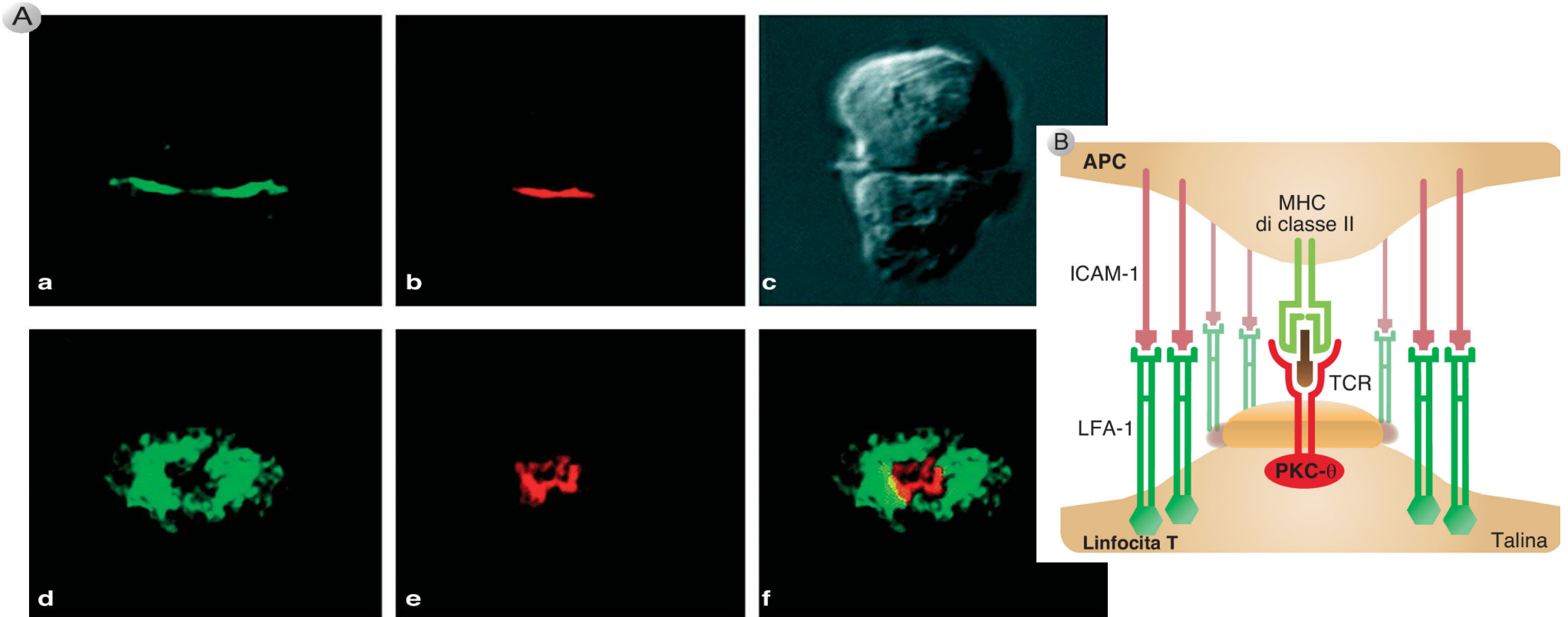

Peripheral SMAC
(pSMAC)

Central SMAC
(cSMAC)

Different views of the immunological synapse (a-c) and (d-f) with an APC-T cell conjugate. The talin is visualized in green and the PKC-θ in red.

SMAC=supramolecular activation cluster

Citoscheletro, granuli secretori e meccanismo di citotossicità dei linfociti T CD8+ citotossici e delle cellule NK

Formazione della sinapsi immunologica

MTOC= centro di organizzazione dei microtubuli

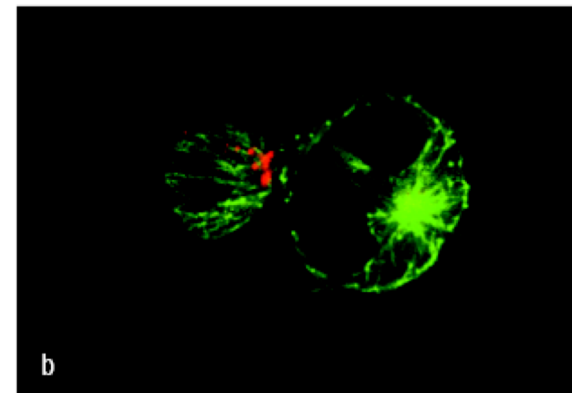
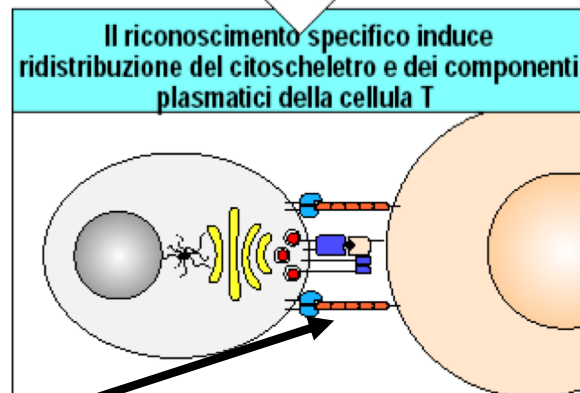
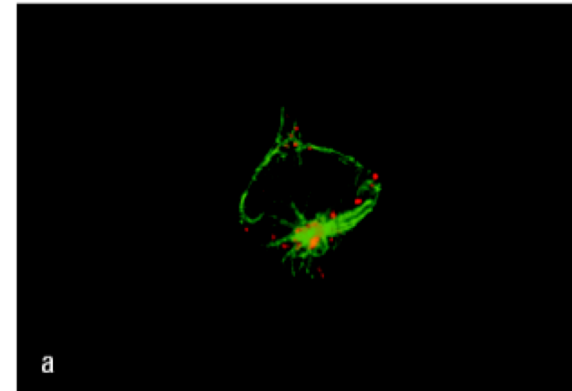
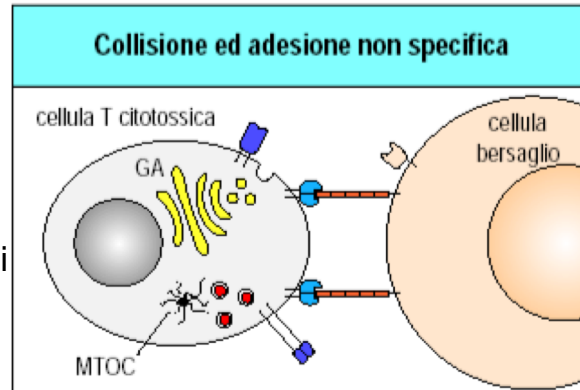

Microtubuli

Granuli citotossici

Formazione della sinapsi immunologica

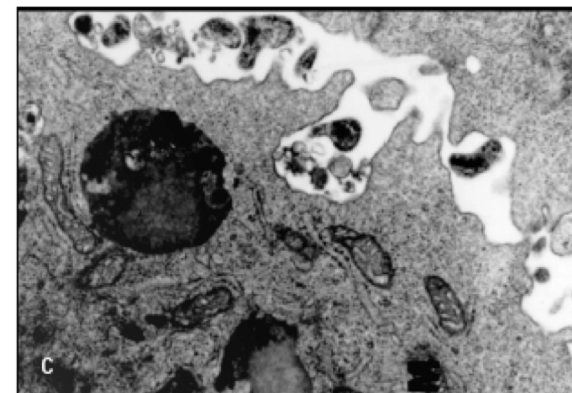
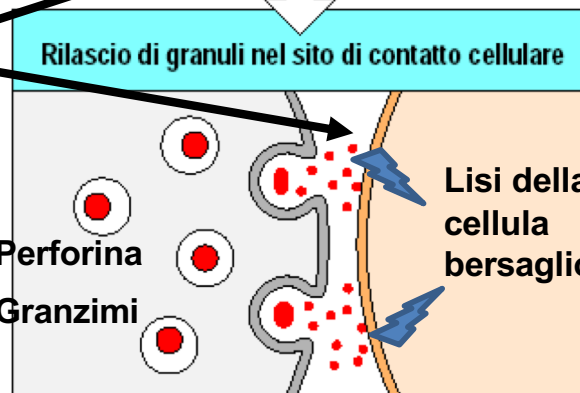

Sequence of events during cytotoxic T lymphocyte (CTL) killing of a cognate target cell

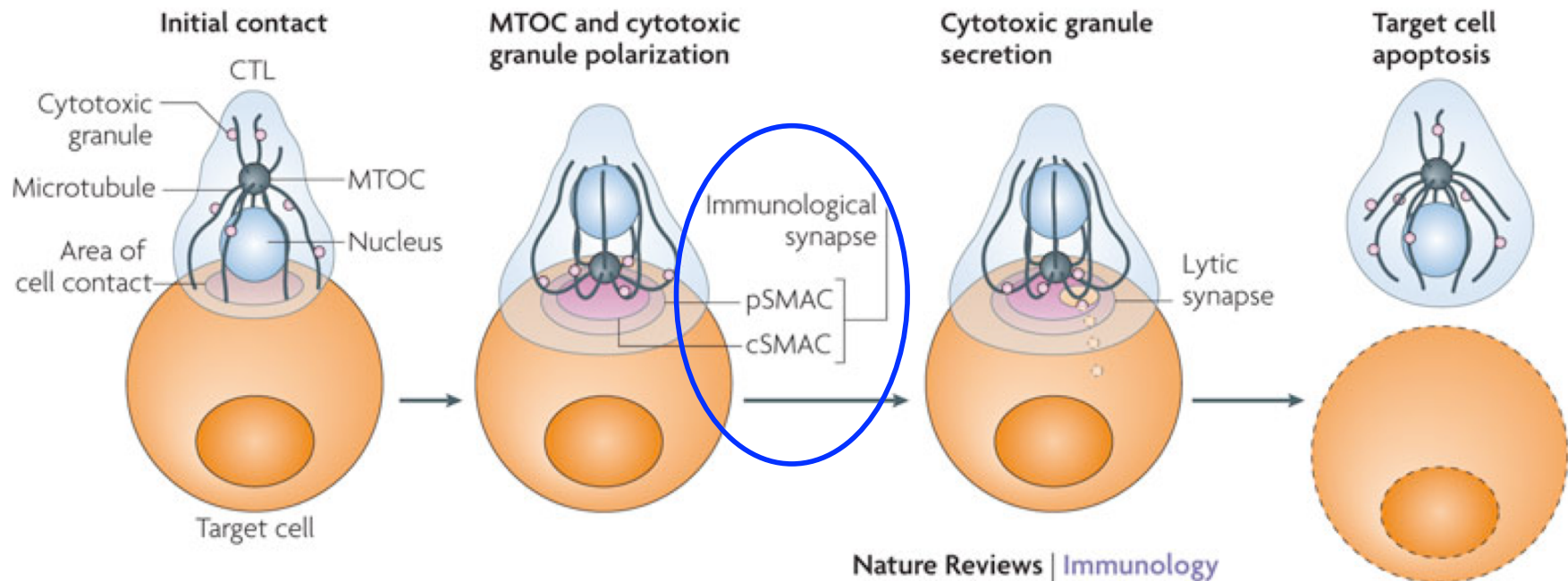

Following antigen-dependent recognition of a target cell, CTLs form a transient conjugate with the target cell. The CTL rapidly reorientates its **microtubule-organizing centre (MTOC)** and the entire microtubule network towards the contact site, where an immunological synapse is being organized. The cytotoxic synapse is organized into a **central supramolecular activation complex (cSMAC)**, where signalling molecules and T cell receptors (TCRs) are localized, surrounded by a peripheral integrin-rich ring, the **peripheral SMAC (pSMAC)**, which defines the boundary of the synapse. Within minutes of stimulation, cytotoxic granules move along microtubules in a minus-end direction and then cluster around the MTOC.

The granules are then delivered to the plasma membrane at the synapse by the MTOC directly contacting the plasma membrane. Cytotoxic granule content is released into a small secretory cleft (yellow) formed between the CTL and target cell. The release of perforin induces the entry of granzymes into the target cell. Rapid death of the target cell by apoptosis ensues. Only some cytotoxic granules are secreted, enabling CTLs to carry out repeated cycles of antigen recognition, polarization and cytolysis.

Formazione della sinapsi immunologica nelle cellule Natural Killer

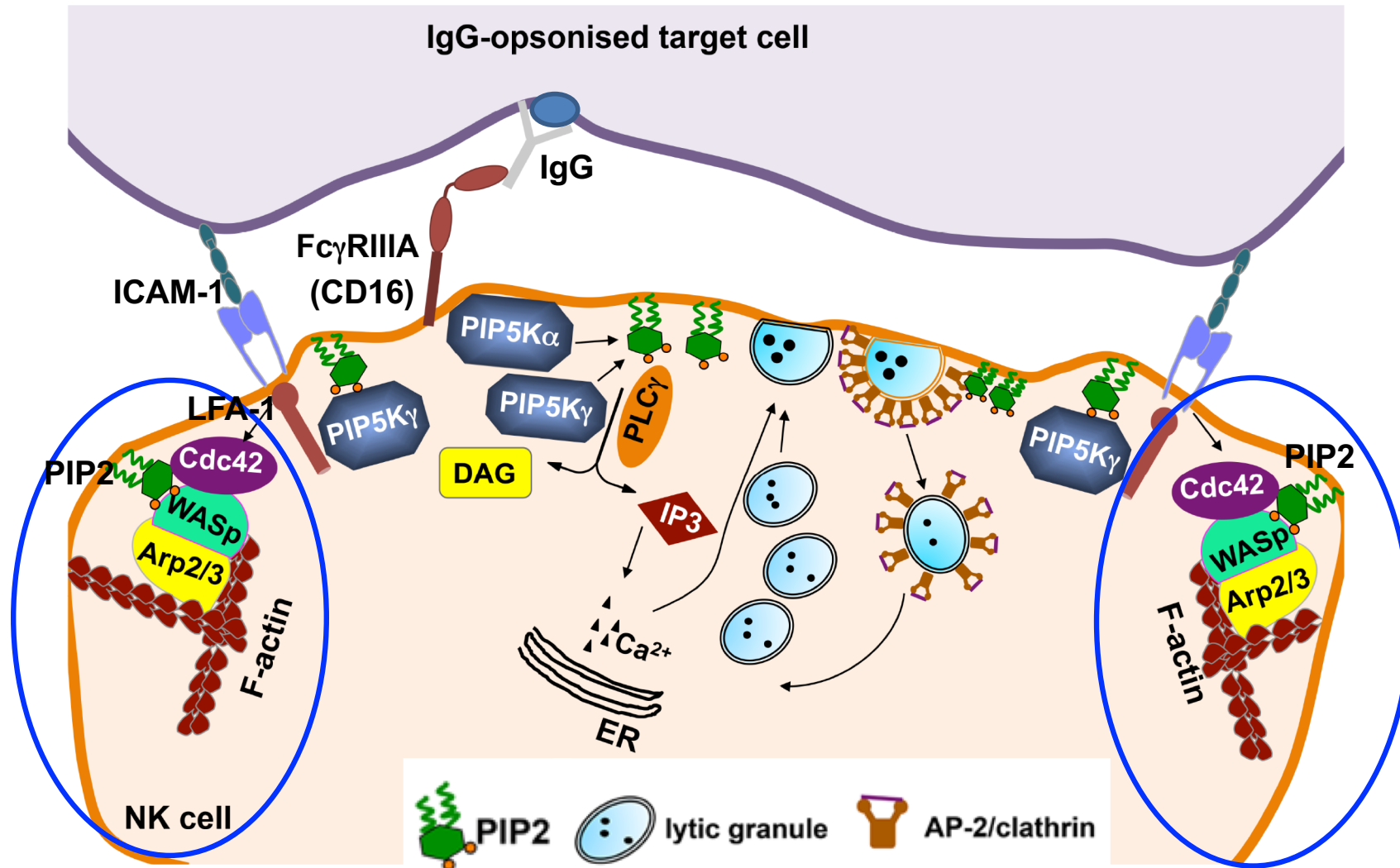

In NK cells, **WASP** participates in the synapse formation and polarization of perforin to the immune synapse for NK cell cytotoxicity

Citoscheletro e fagocitosi

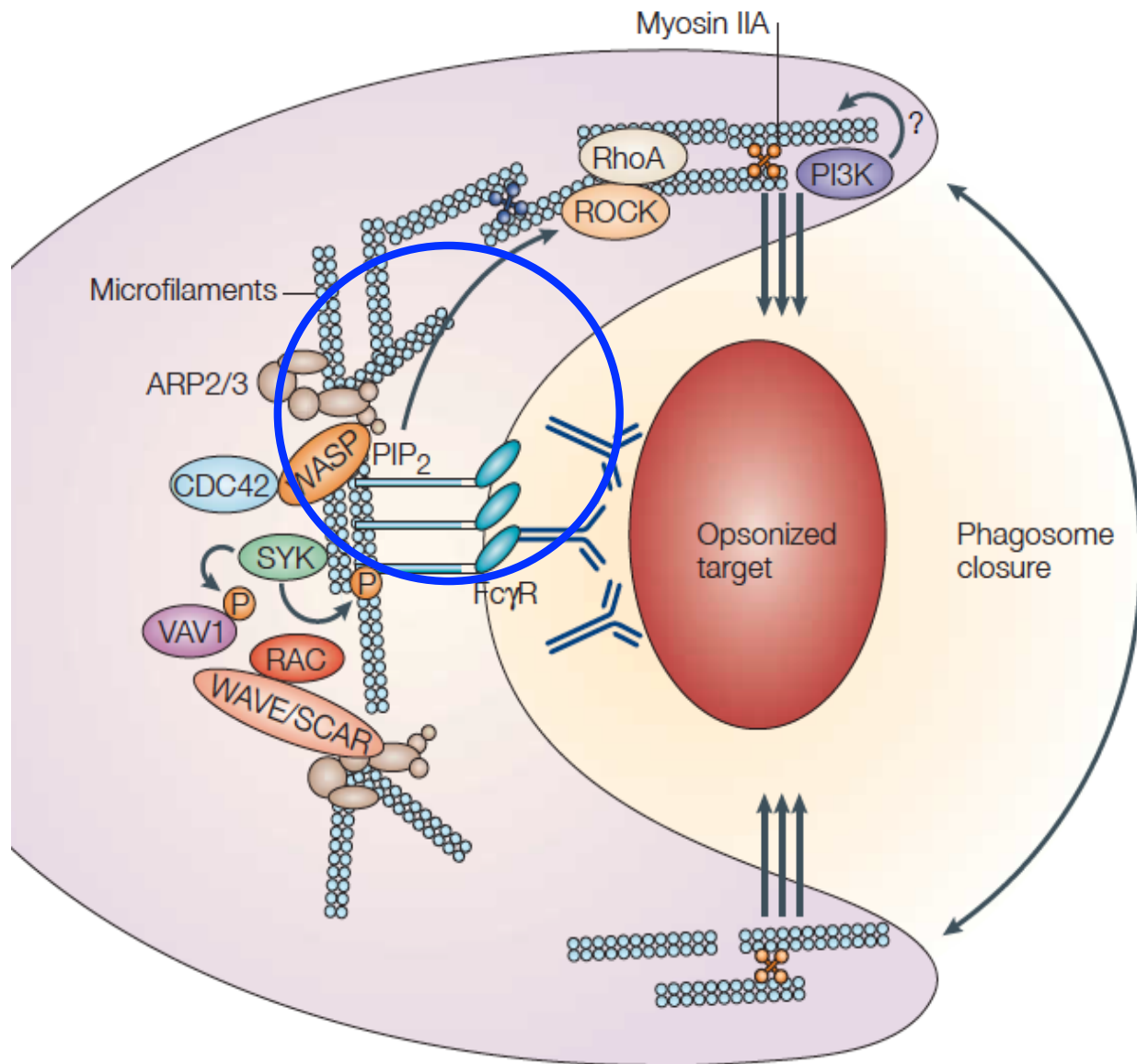

During phagocytosis mediated by activation of Fcγ receptors (FcγRs), PIP₂ is crucial for the assembly and polymerization of F-actin.

It accumulates in the inner leaflet of phagosomal cup and recruits/activates actin polymerization proteins (profilin, cofilin, talin, vinculin, **WASP**, ezrin-radixin-moesin family members, etc).

Citoscheletro nei mastociti

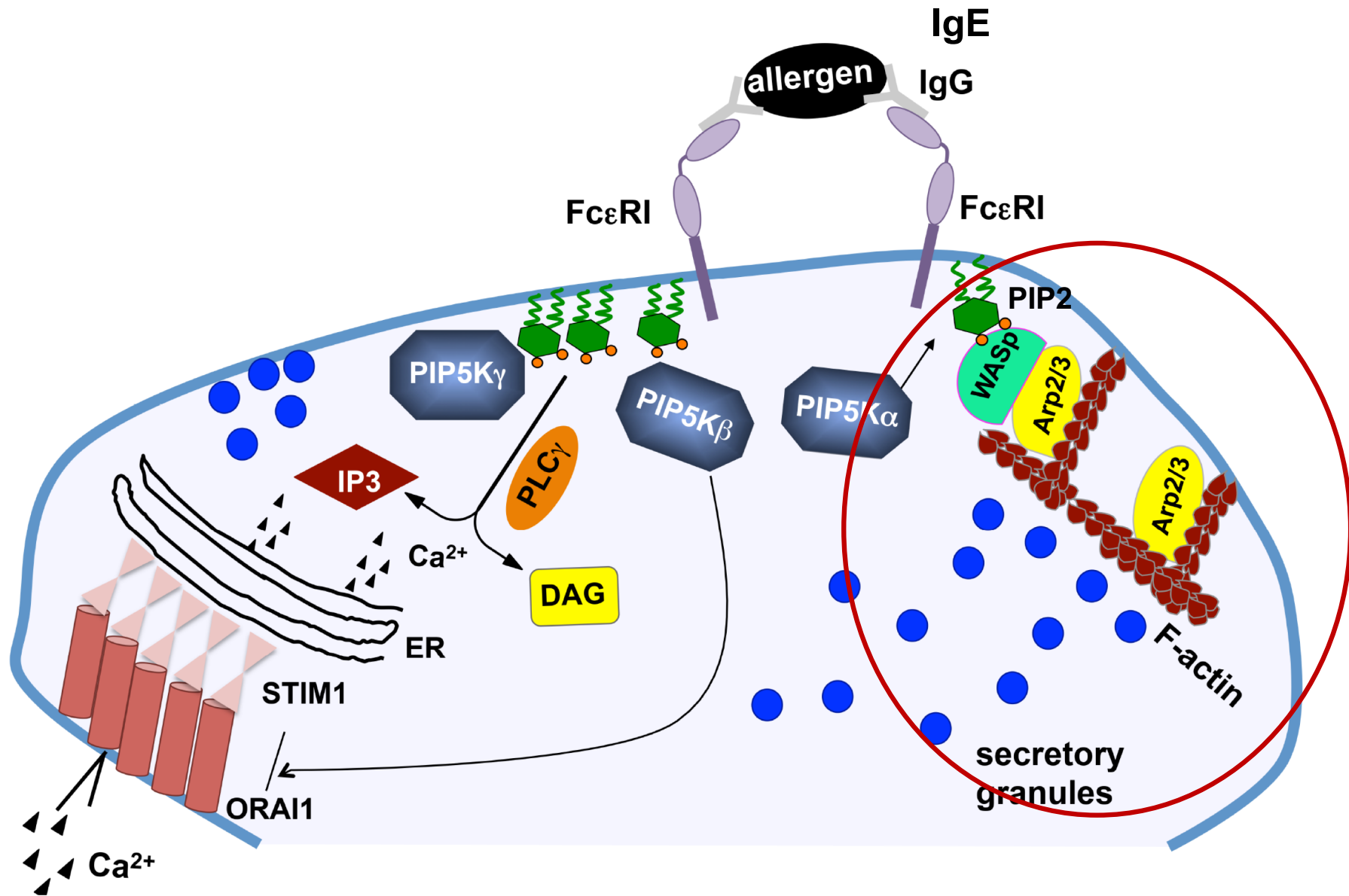

La dinamica dell'actina rappresenta un aspetto primario del processo di degranulazione dei mastociti.

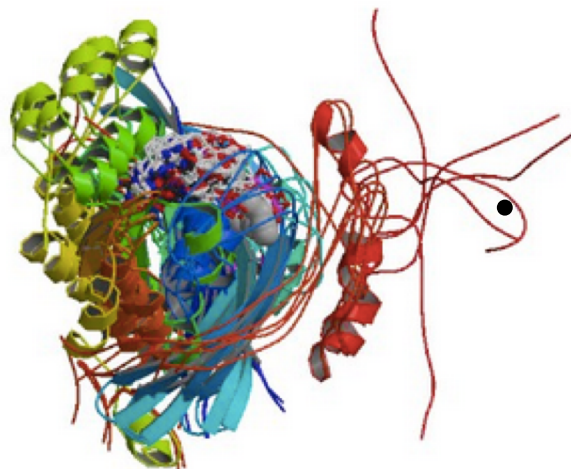

Proteina WASP

- Gene responsabile della comparsa della **sindrome di WISKOTT–ALDRICH (WAS; una immunodeficienza complessa)** che è stato identificato nel 1994 mediante clonaggio posizionale (Derry et al. 1994)
- Localizzato sul cromosoma X (Xp11.23-p11.22)
- Sono state identificate circa 200 mutazioni che colpiscono sia le regioni codificanti che i siti di splicing
- Le diverse mutazioni si associano ad eterogeneità delle manifestazioni fenotipiche nella WAS.

Disease	Mutation type	Effect of mutation	WASP expression	Clinical features	Complications
Classical WAS	Nonsense, deletions, insertions, splice anomalies and missense mutations, especially outside exons 1–3	Loss of function	Usually absent	Microthrombocytopenia, moderate to severe eczema and recurrent or severe infections	Autoimmunity and haematopoietic cell malignancy
XLT	Most commonly missense mutations, especially in exons 1–3, or splice anomalies	Loss of function	Usually present at low levels	Microthrombocytopenia, mild to moderate eczema and no increased infections or recurrent minor infections	Autoimmunity
XLN	Missense mutations in the VCA binding domain	Disrupted autoinhibition	Present	Neutropenia, monocytopenia, NK cytopoenia and myelodysplasia	Not determined

NK, natural killer; VCA, verprolin homology domain–cofilin homology domain–acidic region; WAS, Wiskott–Aldrich syndrome; WASP, WAS protein; XLN, X-linked neutropenia; XLT, X-linked thrombocytopenia.

Nella WAS: difetti a carico dell'immunità

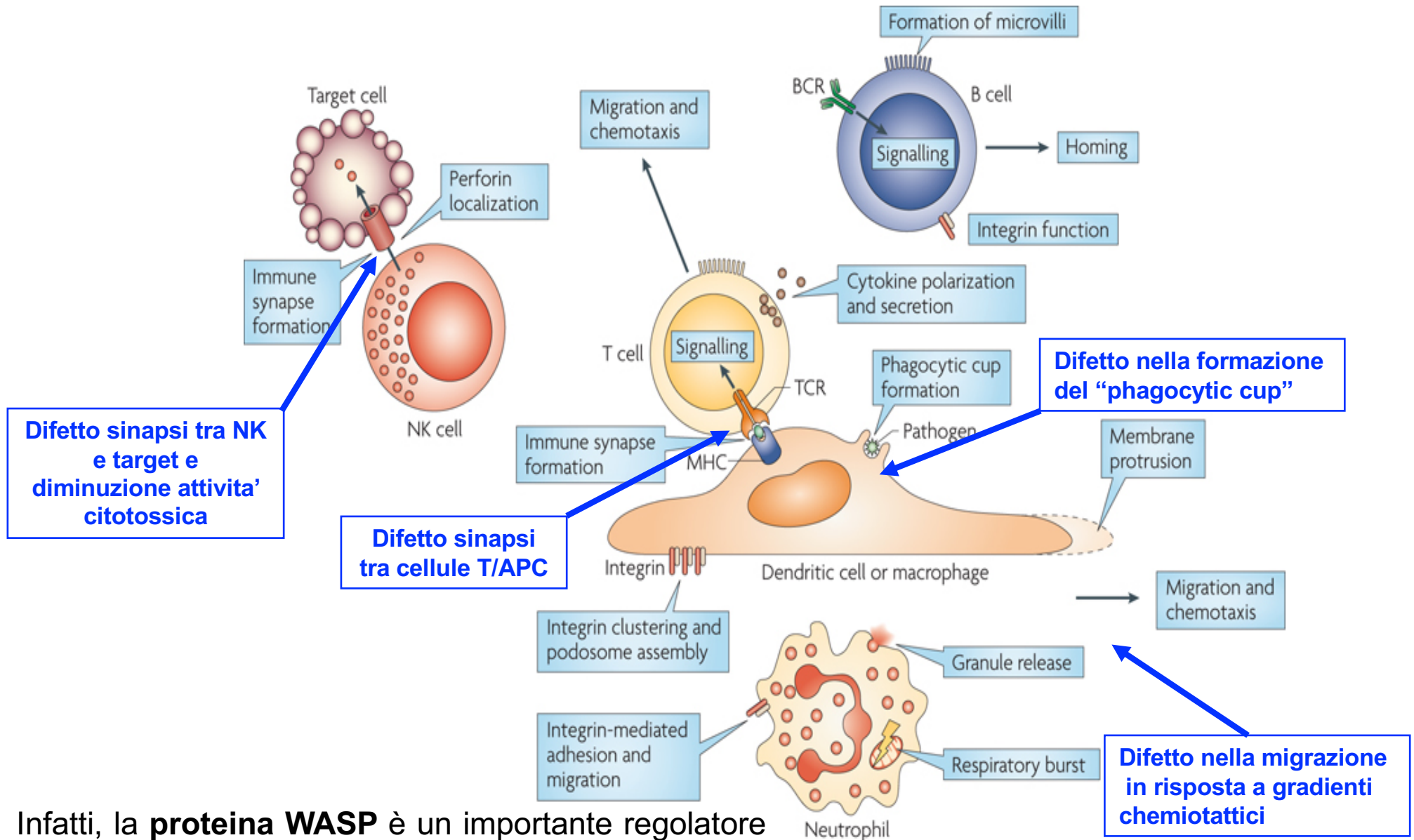

Infatti, la **proteina WASP** è un importante regolatore dell'**organizzazione dell'actina** nel citoscheletro ed è richiesta per molte funzioni ematopoietiche e del sistema immunitario tra cui **migrazione**, formazione di **sinapsi immunologica** e **fagocitosi**.

WASP: espressa esclusivamente dalle cellule ematopoietiche

WASP family members:

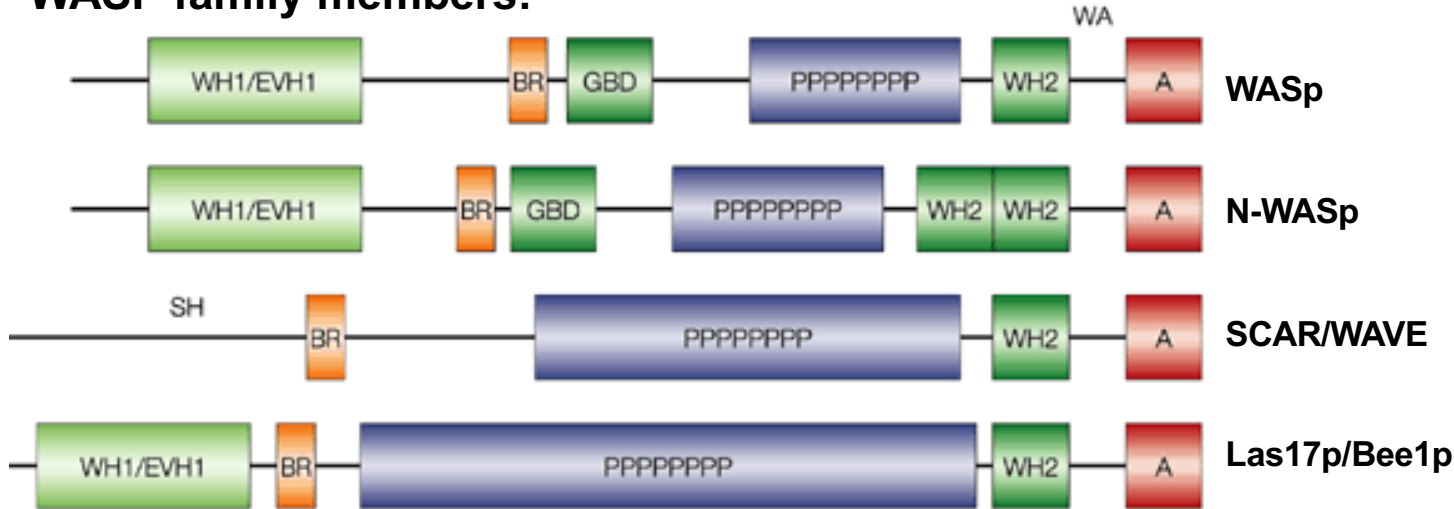

WASP è una proteina "scaffold"

di 502 aa priva di attività catalitica che trasducendo segnali da altre proteine e dalla membrana induce cambiamenti dinamici del citoscheletro di actina.

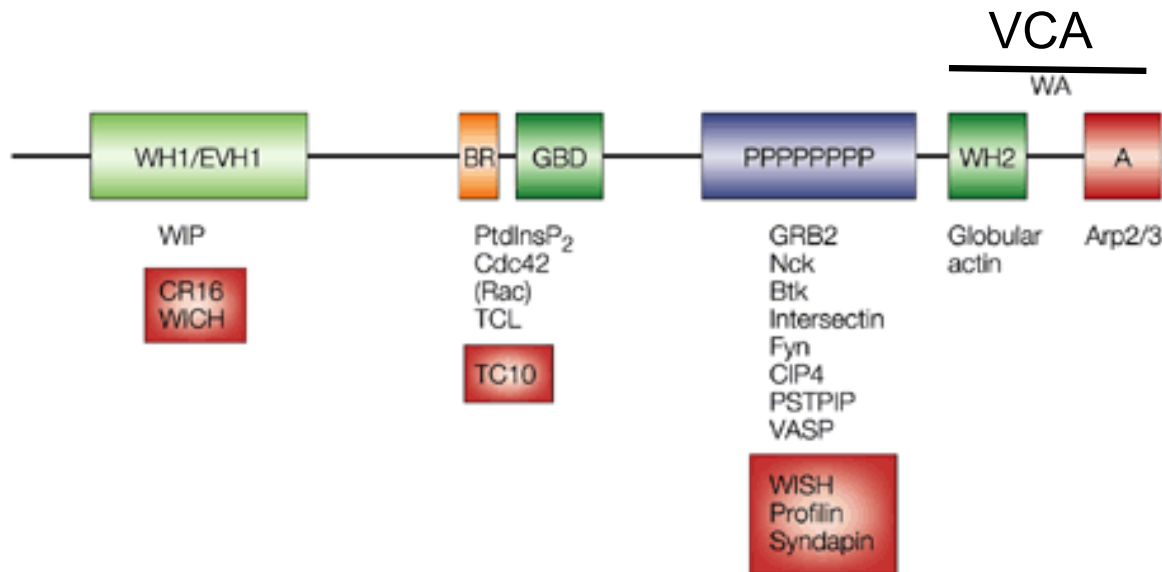

WH1: WASP homology 1

BR: basic region → PIP2

GBD: GTPase binding domain

PPPPP: polyproline region

VCA: Verprolin-Central-Acidic region composto da **WH2** (WASP homology 2) e **A** (acidic region)

Mechanism of WASP activation and Arp2/3-induced actin polymerization

In its inactive state WASP assumes a closed conformation. Following the interaction with active **Cdc42** (small G protein, WASP can interact and activate Arp2/3.

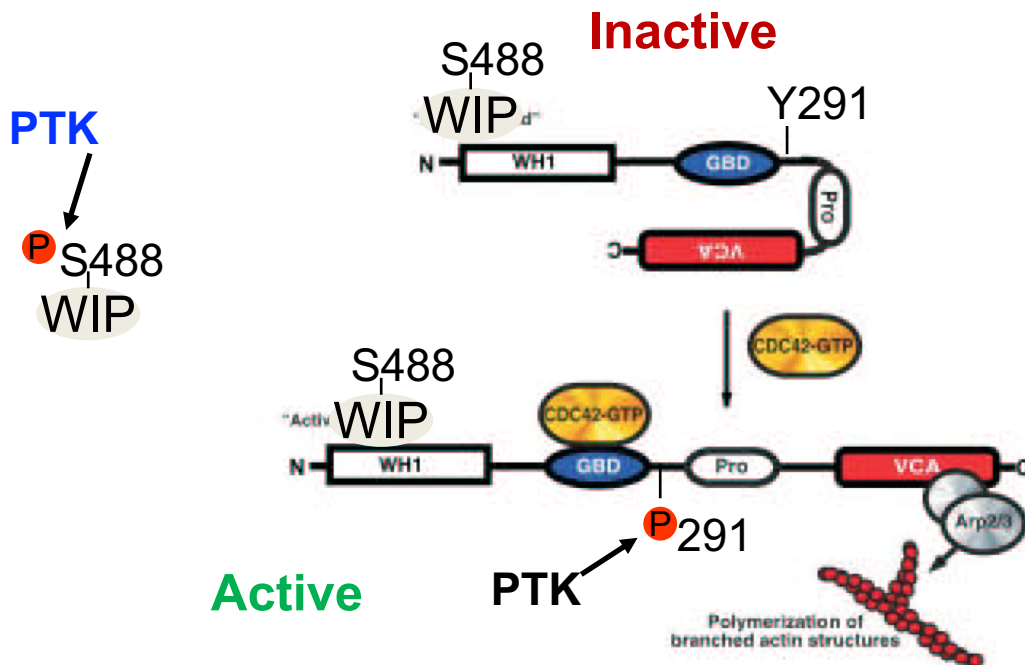

Interaction with **WIP** (WASP interacting protein) protects WASP from degradation. Tyr phosphorylation of WIP is a trigger for release of WASP.

Actin remodeling during T-cell-APC conjugate formation

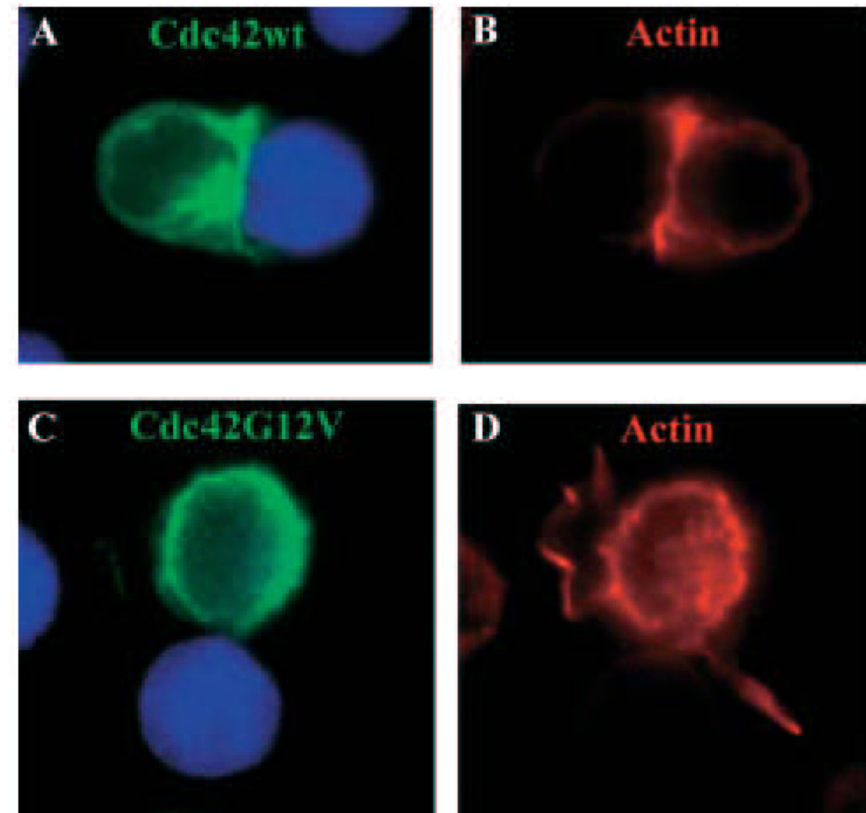

Actin structure is abnormal in T cells (Jurkat T cells) transfected with constitutively active Cdc42

Mechanism of WASP activation

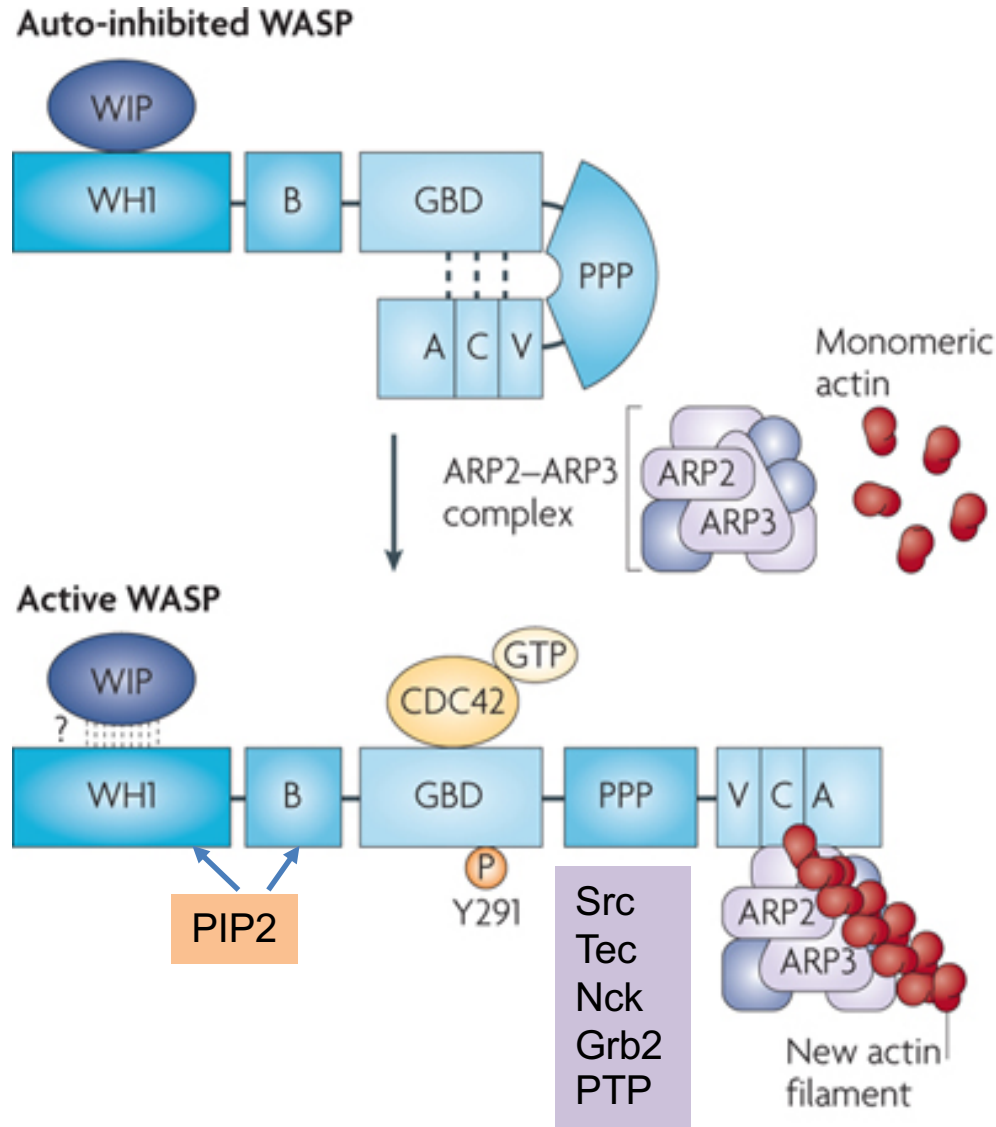

- In its normal state, **WASP** has an **auto-inhibited conformation** in which an **intramolecular interaction between VCA and GBD** prevents binding of the ARP2–ARP3 complex and monomeric actin to the carboxyl terminus.
- **CDC42** a member of Rho family GTPase is the main WASP activator. By binding to the GBD, it causes allosteric release of the VCA from the GBD.

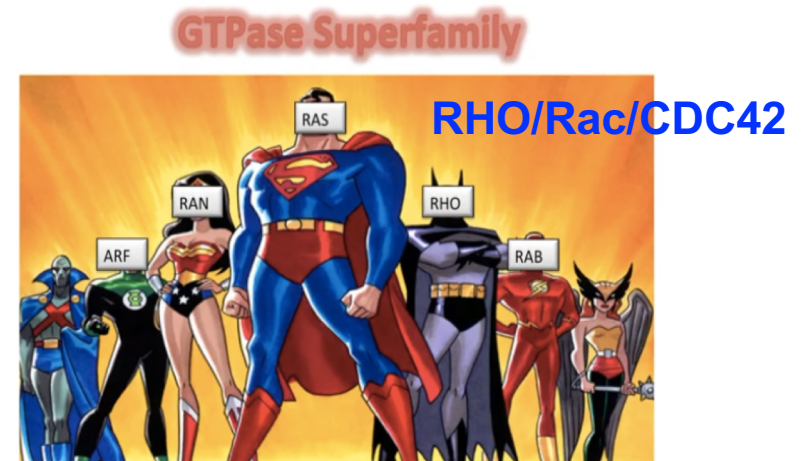

- **Binding with ARP2/3 complex** and polymerization of F-actin.
- **Y291 phosphorylation** by **src kinases** positively regulates WASP activity in a CDC42-independent manner *in vitro*.

WASP binding partners

WASP binding partner	WASP binding domain	Effect on WASP
WIP	WH1	Stabilizes WASP through formation of the WIP–WASP complex, which protects WASP from proteasomal degradation; may chaperone WASP to localize its activity; may have independent activity during cytoskeletal regulation
PtdIns(4,5)P ₂	WH1 and/or basic domain (exact binding site unclear)	Potential WASP activator functioning synergistically with CDC42 and cooperatively with NCK1
ARP2 and ARP3	WH1 and VCA	Main effector complex for WASP activity through nucleation of branching actin polymerization; physiological relevance of binding to WH1 is not clear
GTP-bound CDC42	GBD	Activates WASP in GTP-bound state through disruption of autoinhibited conformation
TOCA1	Basic domain	May be required to dock CDC42 for WASP activation
Other GTPases: TC10 and RAC1	GBD	May contribute to WASP activation, although they bind with lower affinity than CDC42
SRC family tyrosine kinases: HCK, LCK, LYN, FYN and FGR	Polyproline	Activate WASP through tyrosine phosphorylation (Y291) and destabilization of autoinhibited conformation
TEC family kinases: BTK, ITK and TEC	Polyproline	May activate WASP
Adaptors: NCK, GRB, CRKL, syndapin, intersectin 2 and PSTPIP1	Polyproline	Activate WASP; NCK may be independent of CDC42 but interdependent with PtdIns(4,5)P ₂ ; intersectin 2 and PSTPIP1 also localize WASP activity
PTPN12	Polyproline	Inactivates WASP through dephosphorylation of Tyr291
VASP	Polyproline	Activates WASP and localizes WASP activity
CK2	VCA	Activates WASP through serine phosphorylation
Monomeric actin	VCA	Activates ARP2–ARP3 complex



ARP, actin-related protein; BTK, Bruton's tyrosine kinase; CDC42, cell division cycle 42; CK2, casein kinase 2; GBD, GTPase-binding domain; GRB, growth factor receptor-bound protein; HCK, haematopoietic cell kinase; ITK, IL-2-inducible T cell kinase; NCK, non-catalytic region of tyrosine kinase; PSTPIP1, proline-serine-threonine phosphatase-interacting protein 1; PtdIns(4,5)P₂, phosphatidylinositol-4,5-bisphosphate; PTPN12, tyrosine-protein phosphatase non-receptor type 12; TEC, tyrosine kinase expressed in hepatocellular carcinoma; TOCA1, CDC42-dependent actin assembly 1; VASP, vasodilator-stimulated phosphoprotein; VCA, verprolin homology domain-cofilin homology domain-acidic region; WASP, Wiskott–Aldrich syndrome protein; WH1, WASP homology 1; WIP, WASP-interacting protein.

RHO/RAC/CDC42: subfamily of GTPases

Mainly implicated in the control of cytoskeletal events, they coordinate diverse cellular functions, including cell polarity, vesicular trafficking, cell cycle and transcriptomal dynamics.

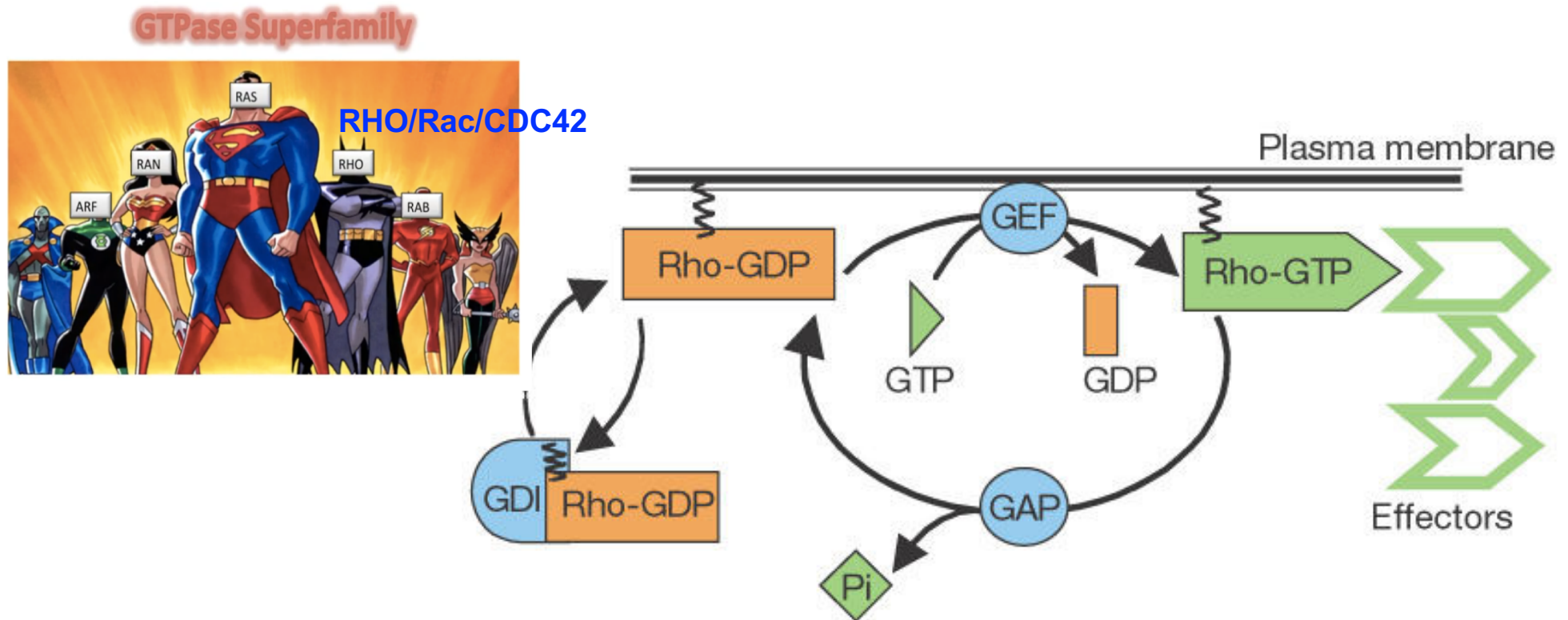

20 Rho GTPases have been identified:

Rho: three isoforms: A, B, C

Rac: 1, 2, 3

Cdc42: TC10; TCL; Chp (1, 2); RhoG; Rnd (1, 2, 3); RhoBTB (1, 2); RhoD; Rif and TT

VAV: fattori di scambio GDP-GTP per RhoA, RAC1 e CDC42 ma anche proteine scaffold

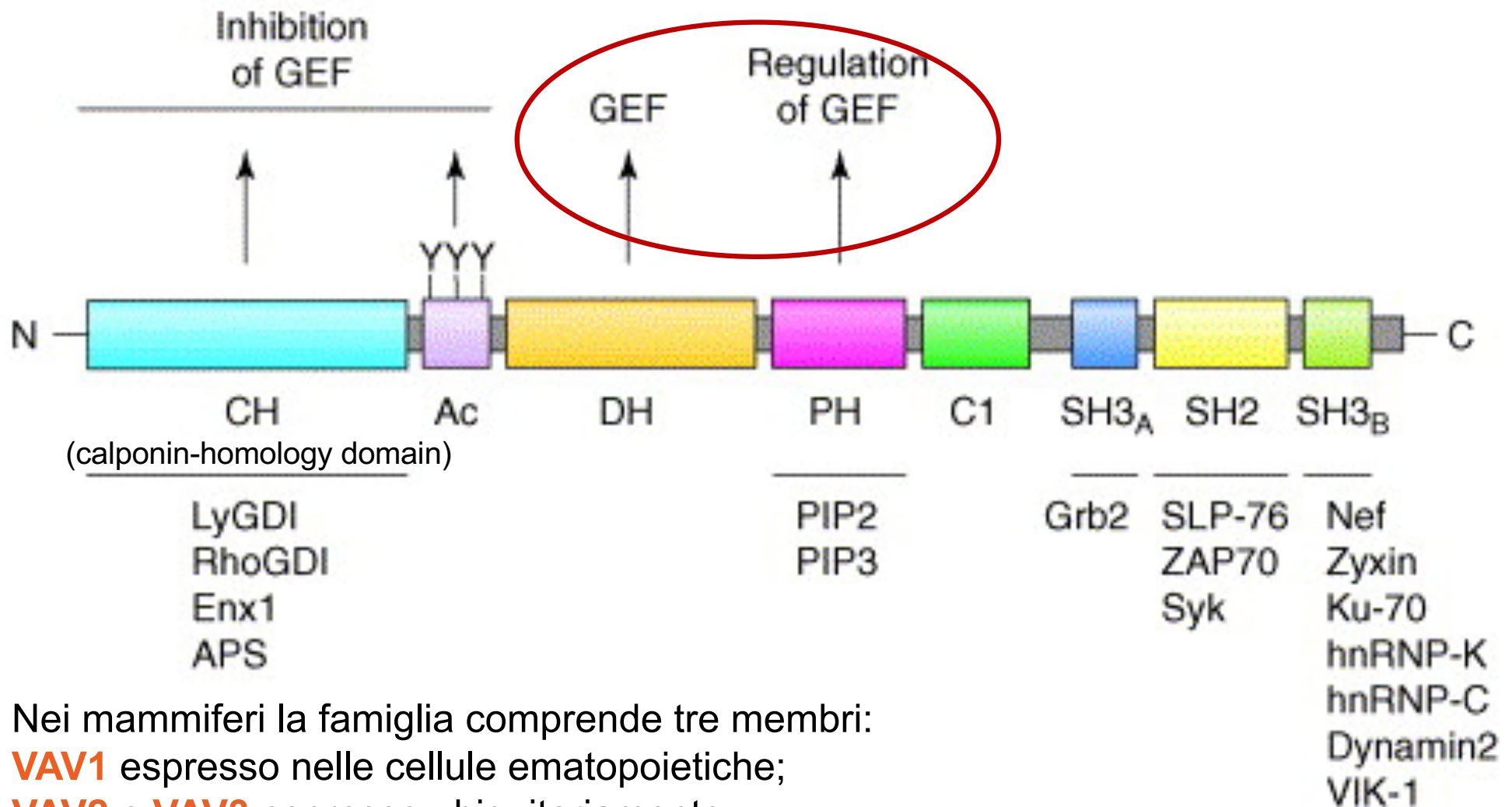

Nei mammiferi la famiglia comprende tre membri:

VAV1 espresso nelle cellule ematopoietiche;

VAV2 e **VAV3** espresse ubiquitariamente.

Queste proteine "**signal transducer**" sono implicate in molti processi che richiedono riorganizzazione del citoscheletro → formazione sinapsi immunologica; fagocitosi; aggregazione delle piastrine.

Attivazione di VAV che agisce come GEF (guanine nucleotide exchange factor) di Rho/RAC/CDC42

Activation of VAV may involve at least three different events to relieve this auto-inhibition.

1. Phosphorylation of the tyrosines in the acidic domain by Syk and Src-family tyrosine kinases
2. Binding of a ligand to the CH domain
3. Binding of PIP₃ to PH domain may alter its conformation

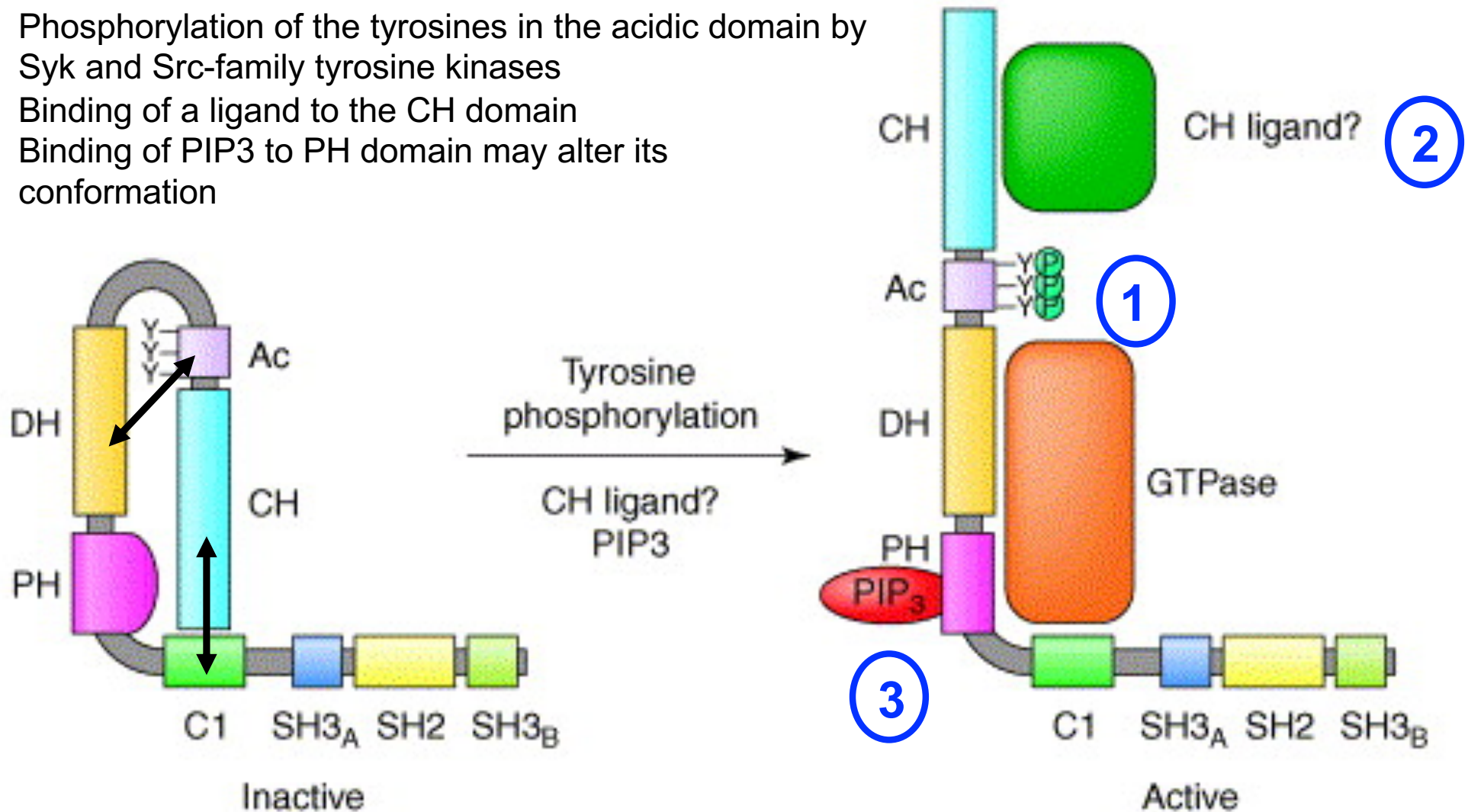

Adattatori e GEFs

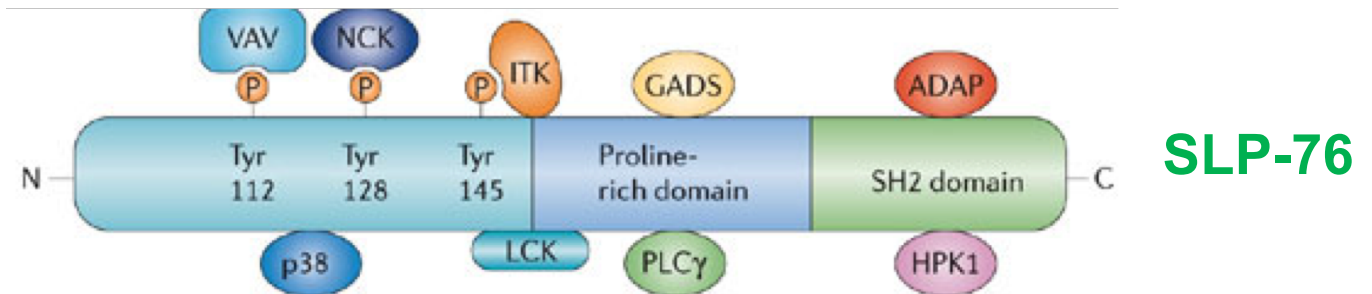
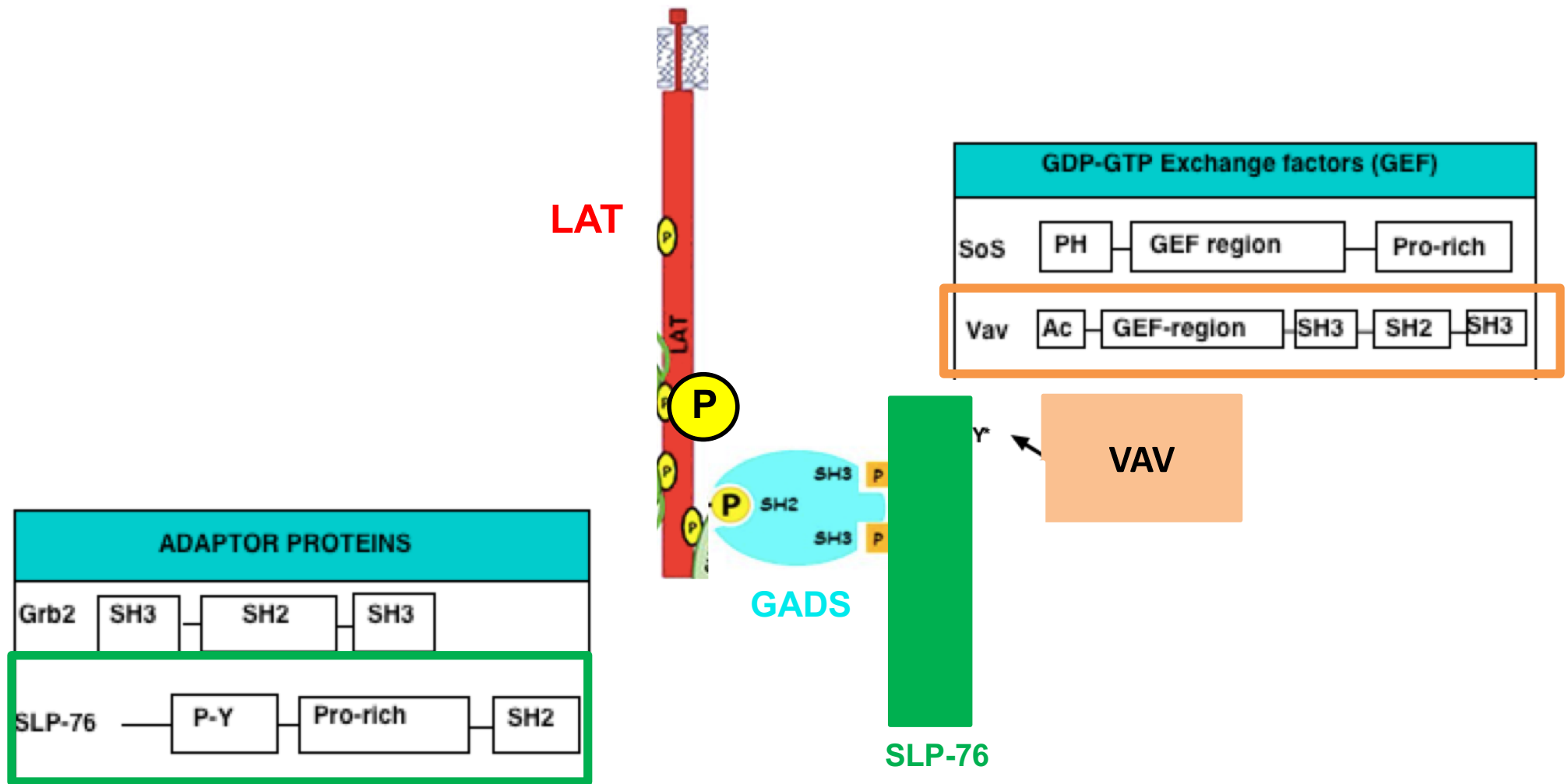

LAT e reclutamento di VAV nei linfociti T

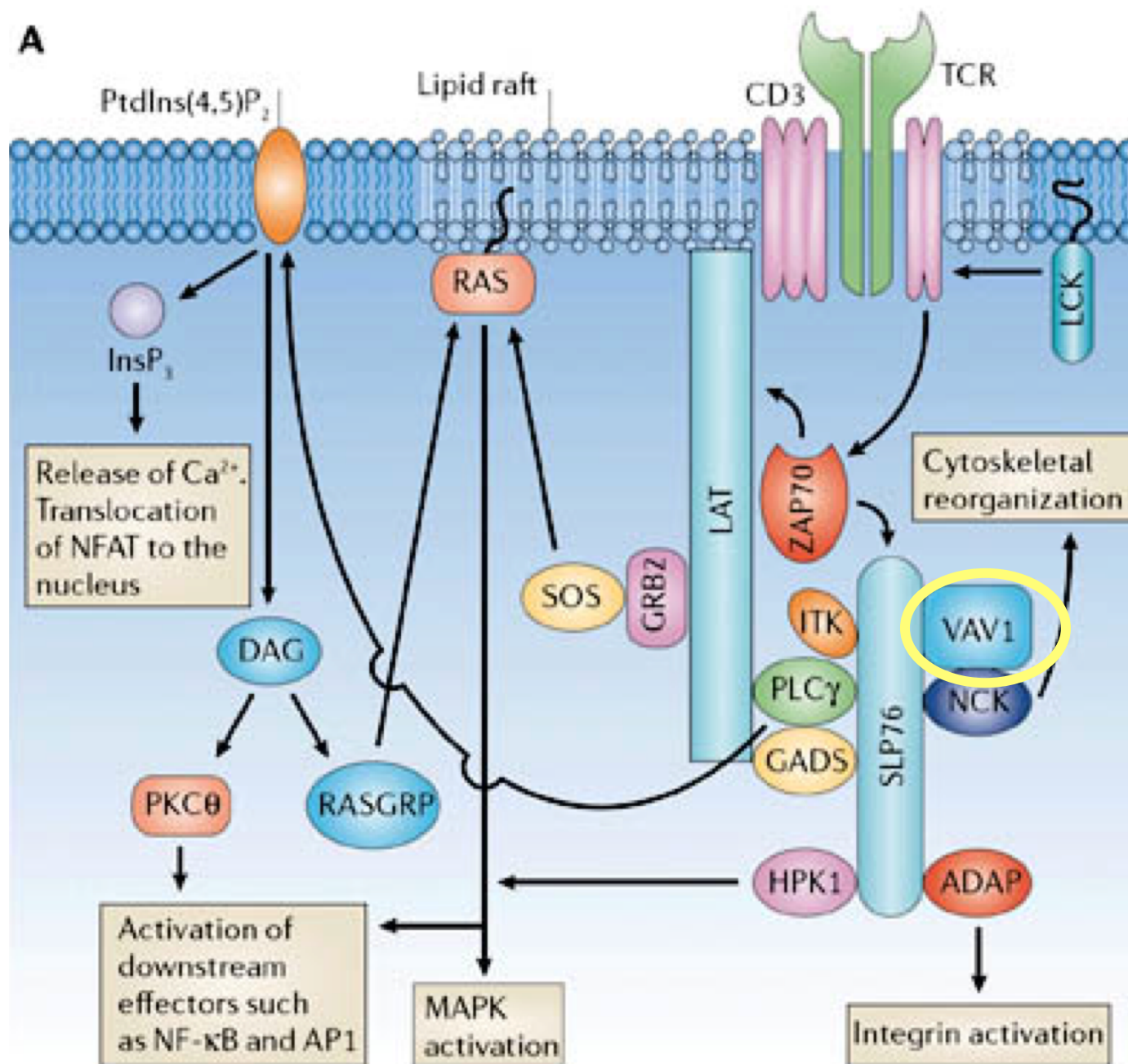

CD28 e reclutamento di VAV nei linfociti T

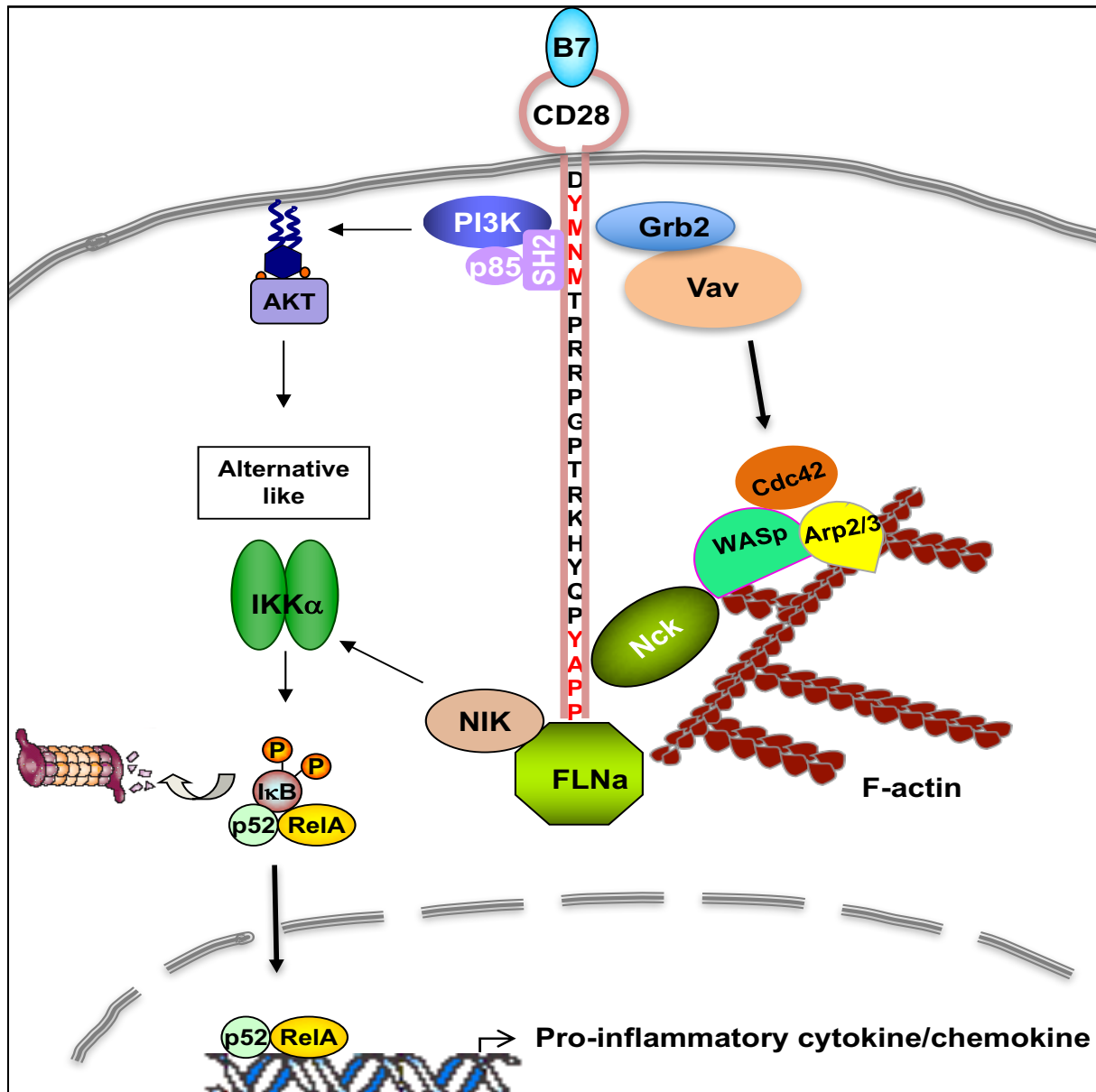

1. La sequenza YMNM fosforilata del **CD28** lega il dominio SH2 di **Grb2** che a sua volta lega **Vav** tramite i domini SH3 → Vav attiva Cdc42
2. La sequenza fosforilata YAPP di **CD28** lega il dominio SH2 di **Nck** che a sua volta lega WASP portandolo in membrana
3. **Cdc42** attiva **WASP** → ARP2/3 e polimerizzazione dell'actina

CD19 e reclutamento di VAV nei linfociti B

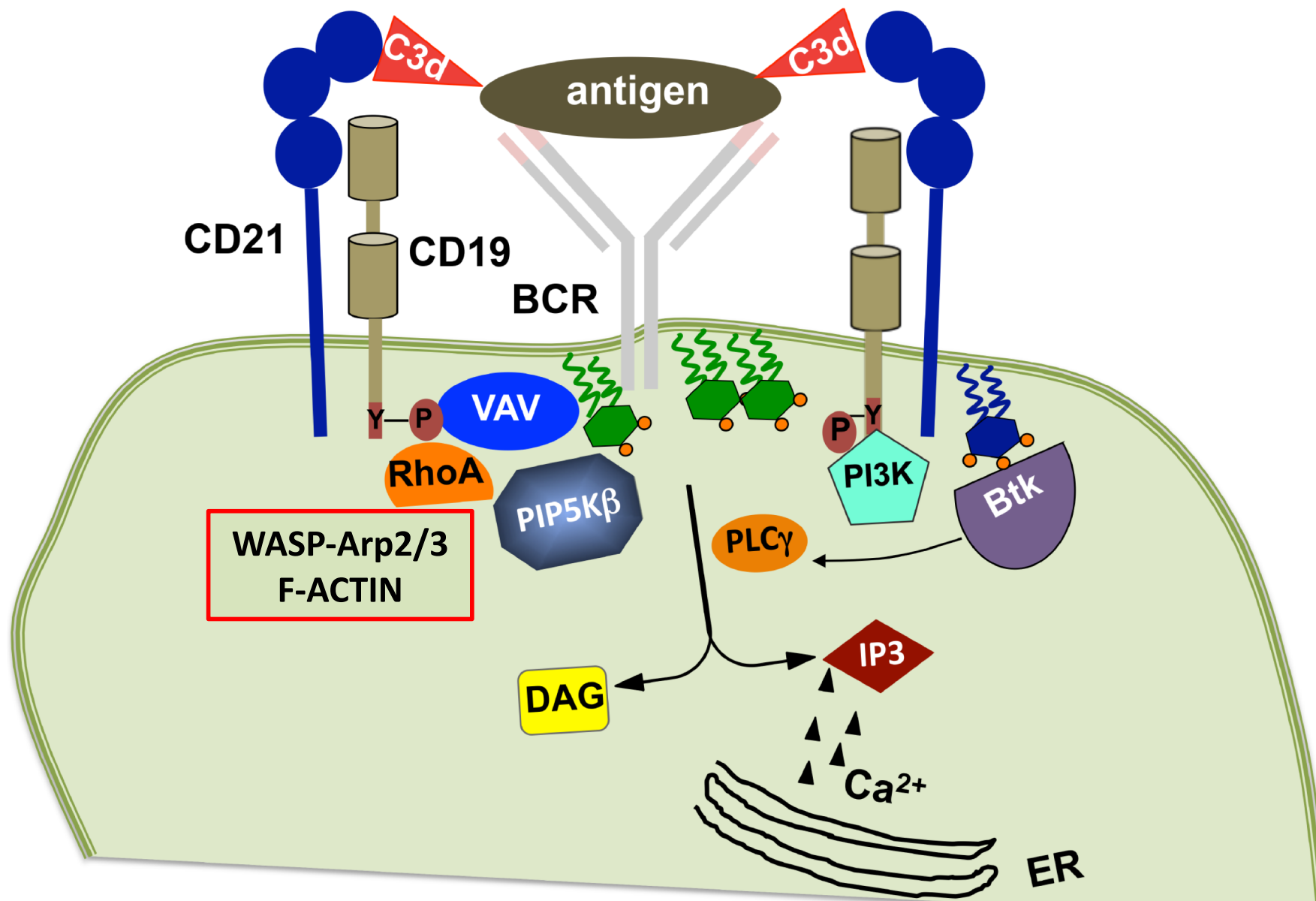

FcεR e reclutamento di VAV nei mastociti

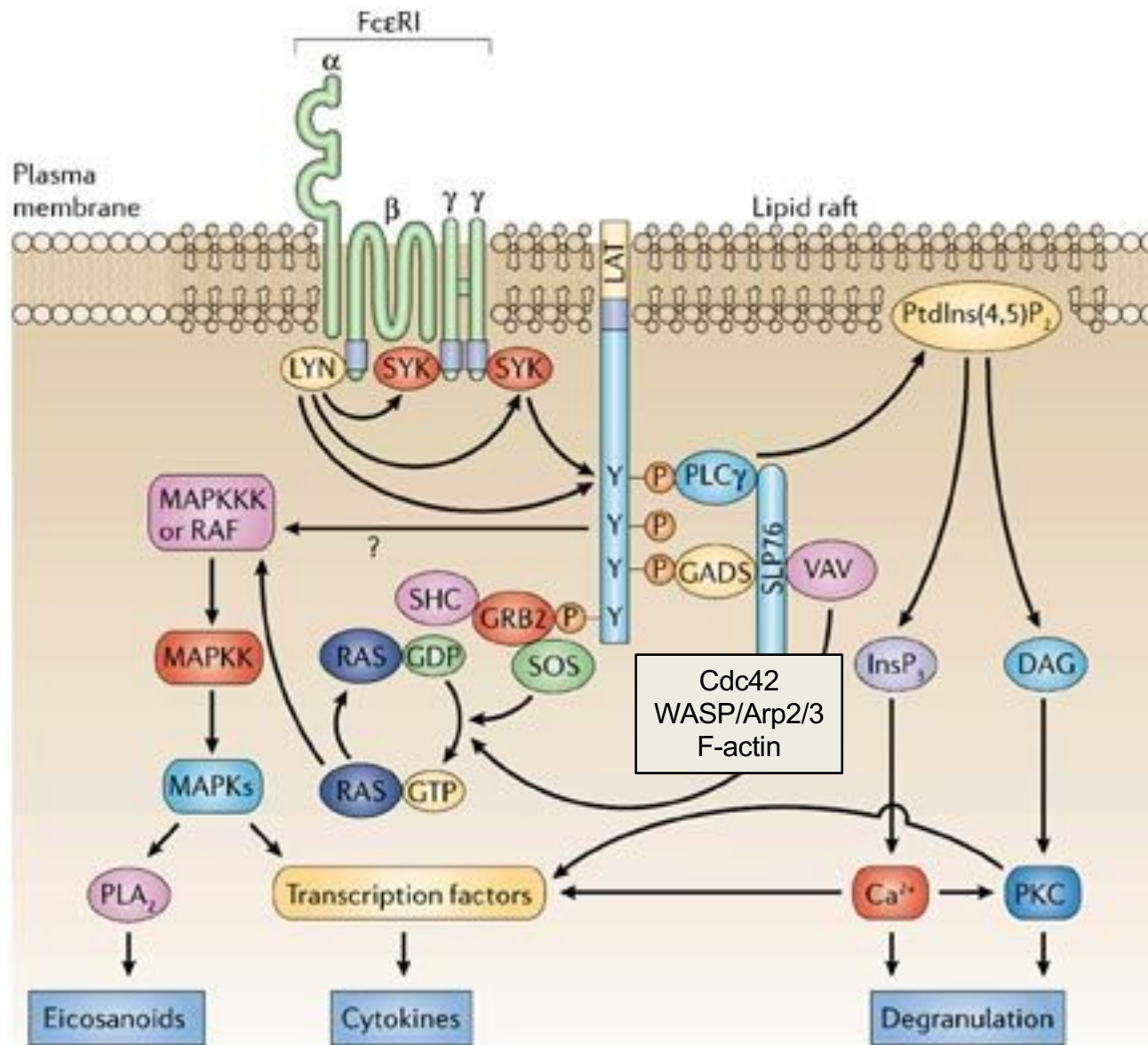

Fc γ R e reclutamento di VAV nei fagociti

