

Parti del testo “Introduzione alla Virologia Moderna” da consultare per questa lezione

- **Capitolo 25 – 25.1, 25.2, 25.3, 25.4, 25.7**

Diversi effetti dell' infezione virale

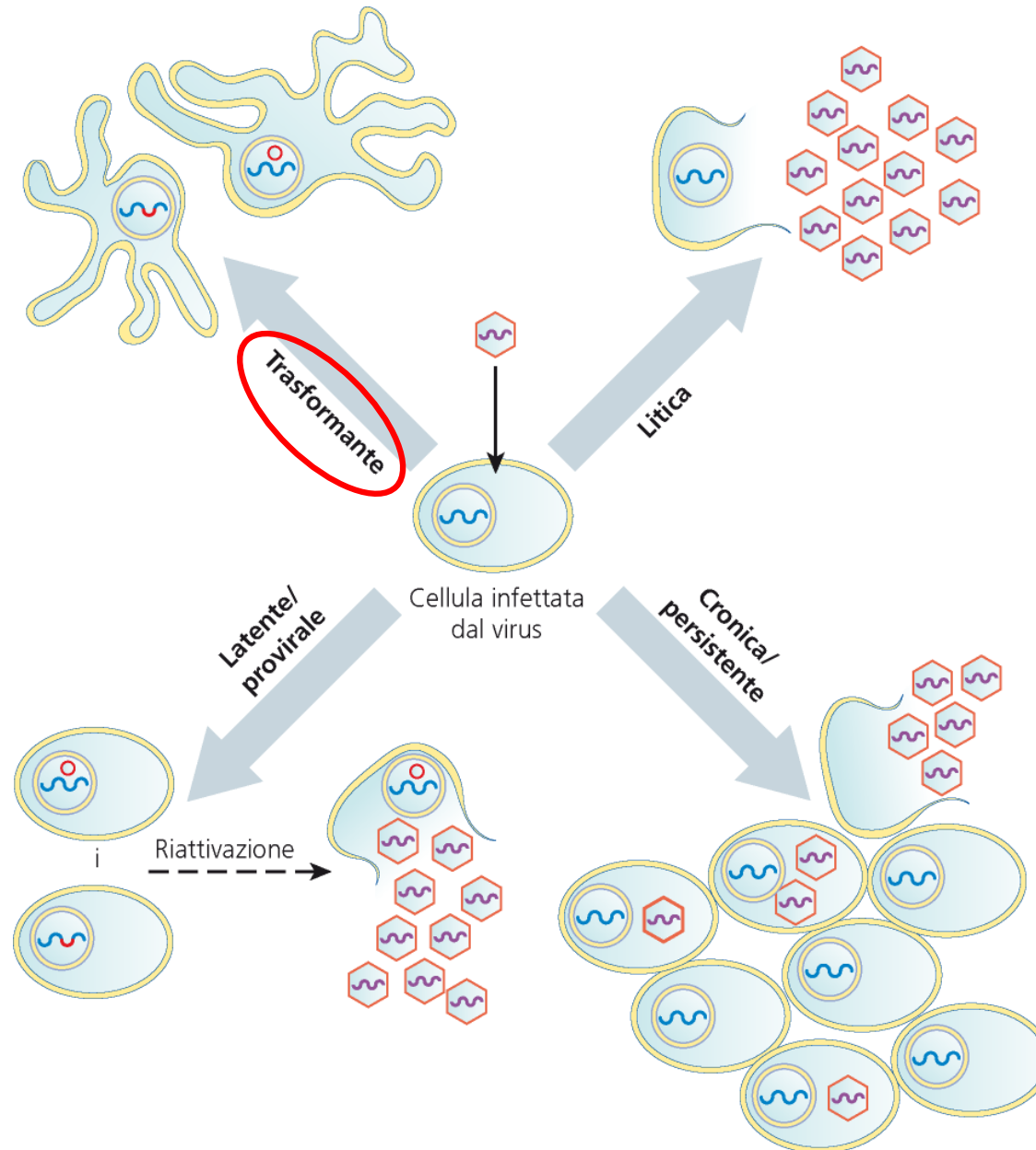

Trasformazione cellulare

La trasformazione cellulare è un processo che può coinvolgere un singolo evento, i.e., un singolo virus trasforma una singola cellula. Il processo di oncogenesi (crescita neoplastica) è un processo che richiede eventi trasformanti successivi che si sommano, **multi-step process**.

Alterazione di tre meccanismi di regolazione fondamentali operanti nelle cellule normali:

- inibizione della proliferazione dovuta al contatto cellula-cellula,
- dipendenza dai fattori di crescita per la proliferazione;
- dipendenza dall' ancoraggio per la proliferazione (molti tipi cellulari)

Trasformazione da retrovirus trasformanti acuti

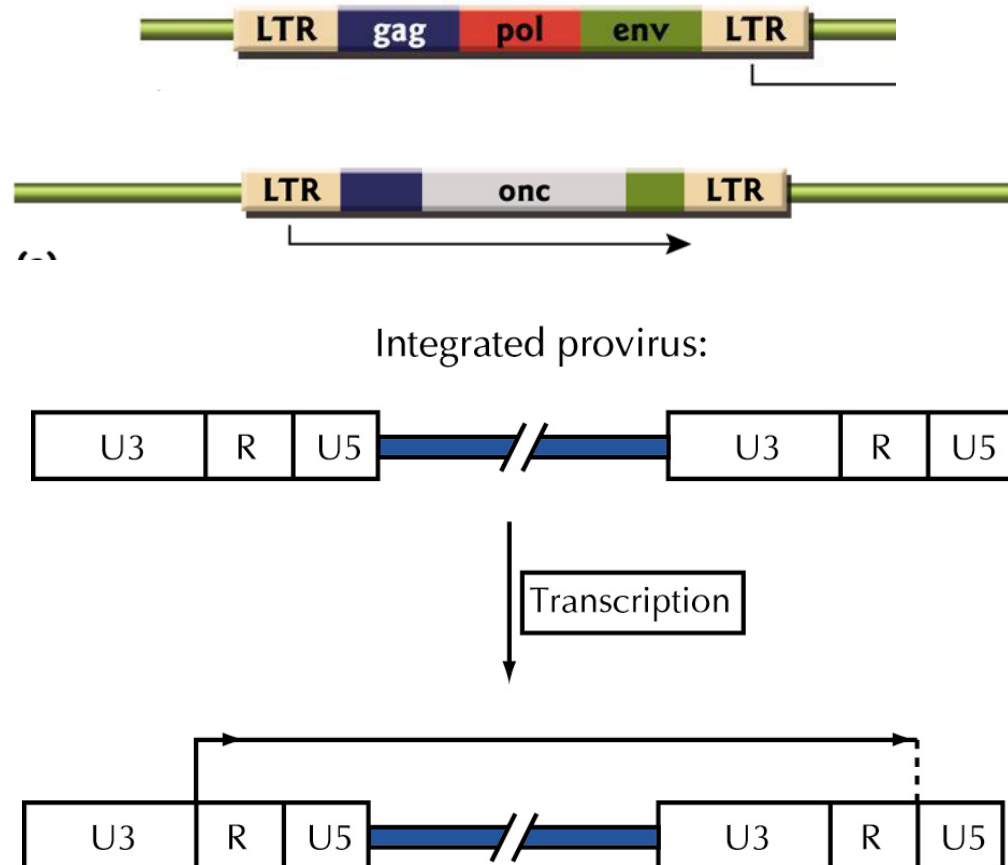

“typical retrovirus”



R U5 GAG POL ENV U3 R

Rous Sarcoma Virus



R U5 GAG POL ENV SRC U3 R

Avian Myeloblastosis Virus



R U5 GAG POL MYB U3 R

Feline Sarcoma Virus (FSV)



R U5 dGAG FMS dENV U3 R

Avian Myelocytoma Virus (MC29)

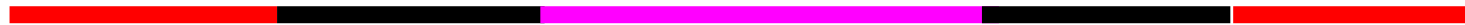

R U5 dGAG MYC dENV U3 R

Trasformazione indotta da retrovirus trasformanti acuti, i.e., che portano oncogeni all'interno del loro genoma

Localizzazione subcellulare di oncoproteine

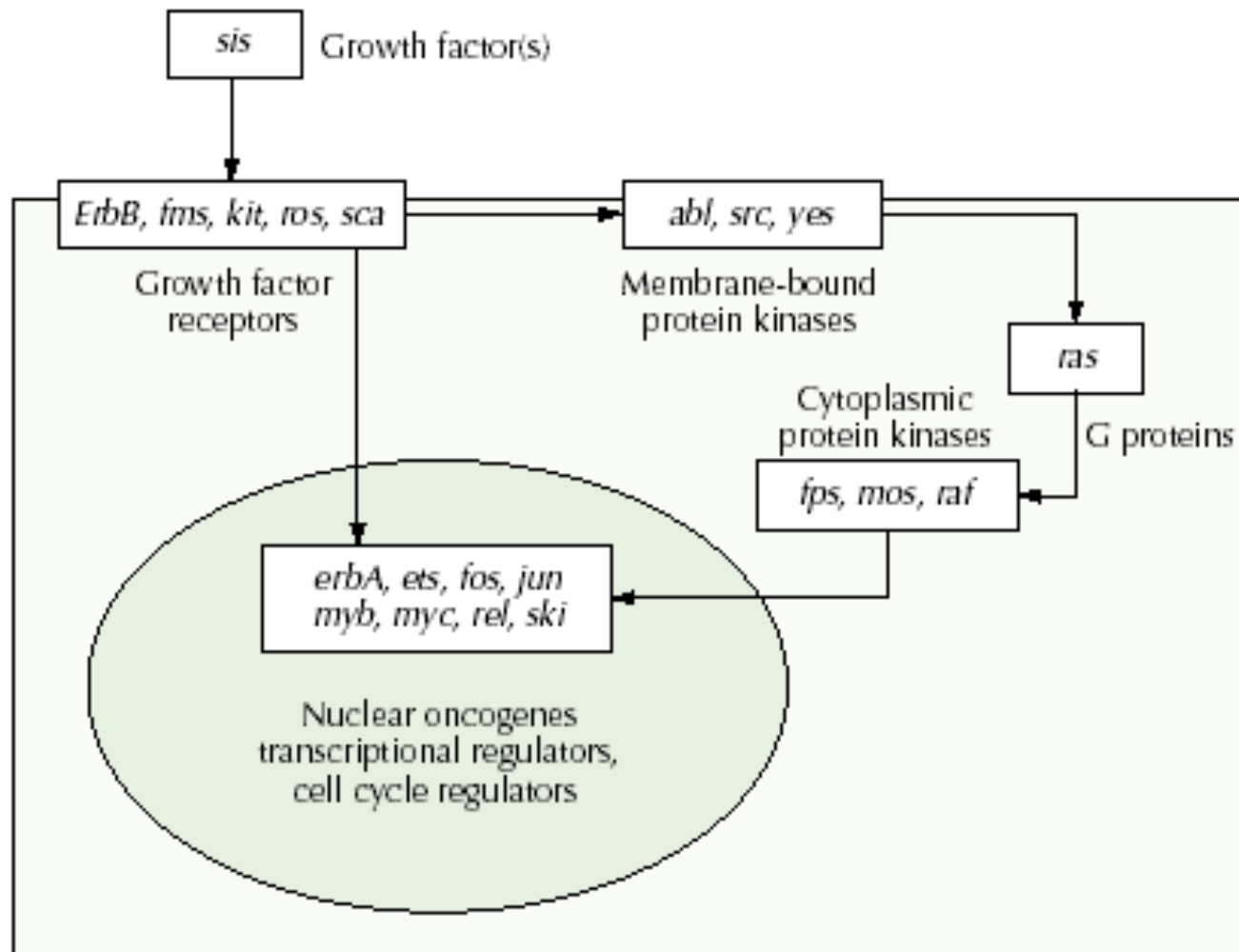

Trasformazione dovuta a mutagenesis inserzionale

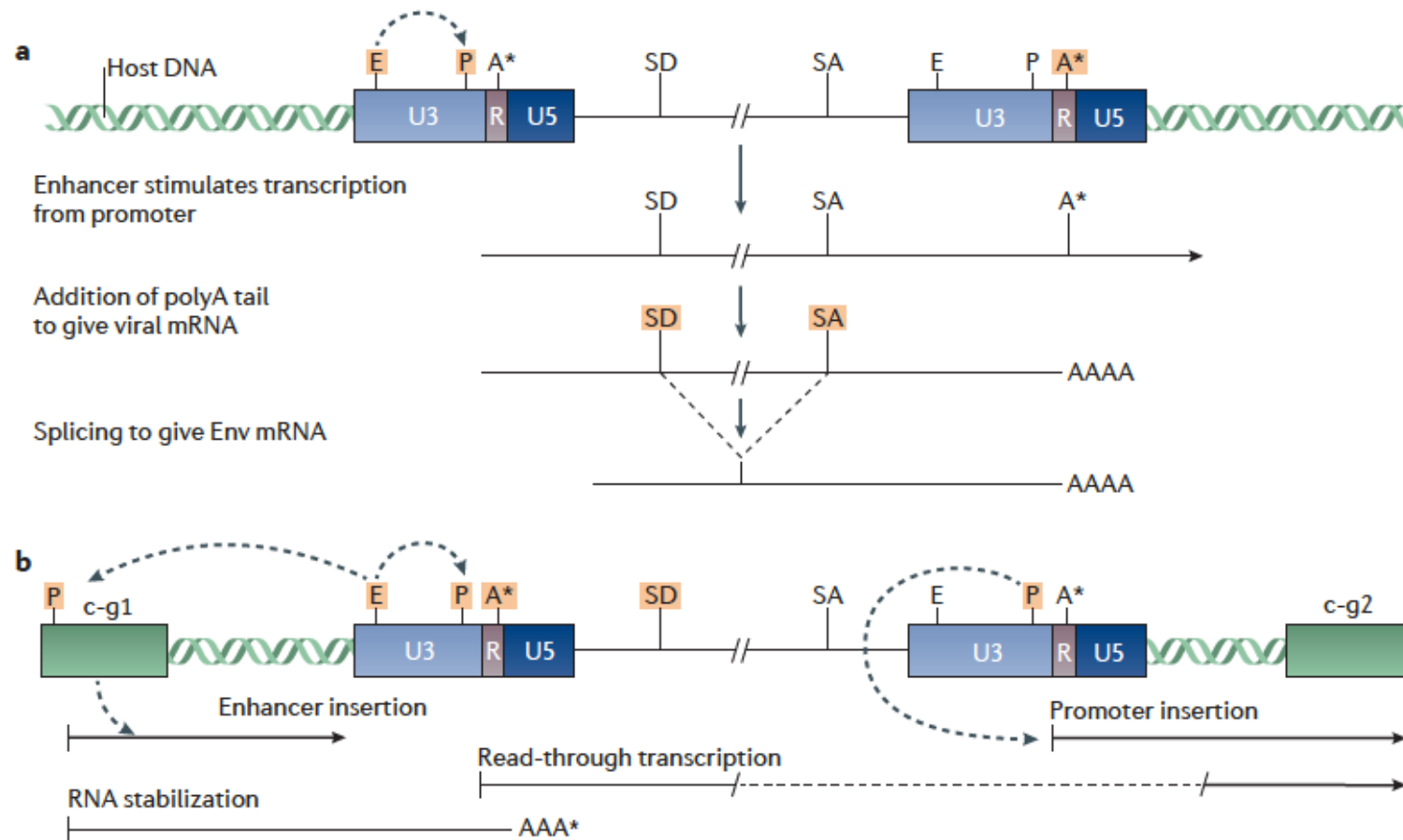

Slowly transforming retroviruses: insertional mutagenesis

Promoter insertion

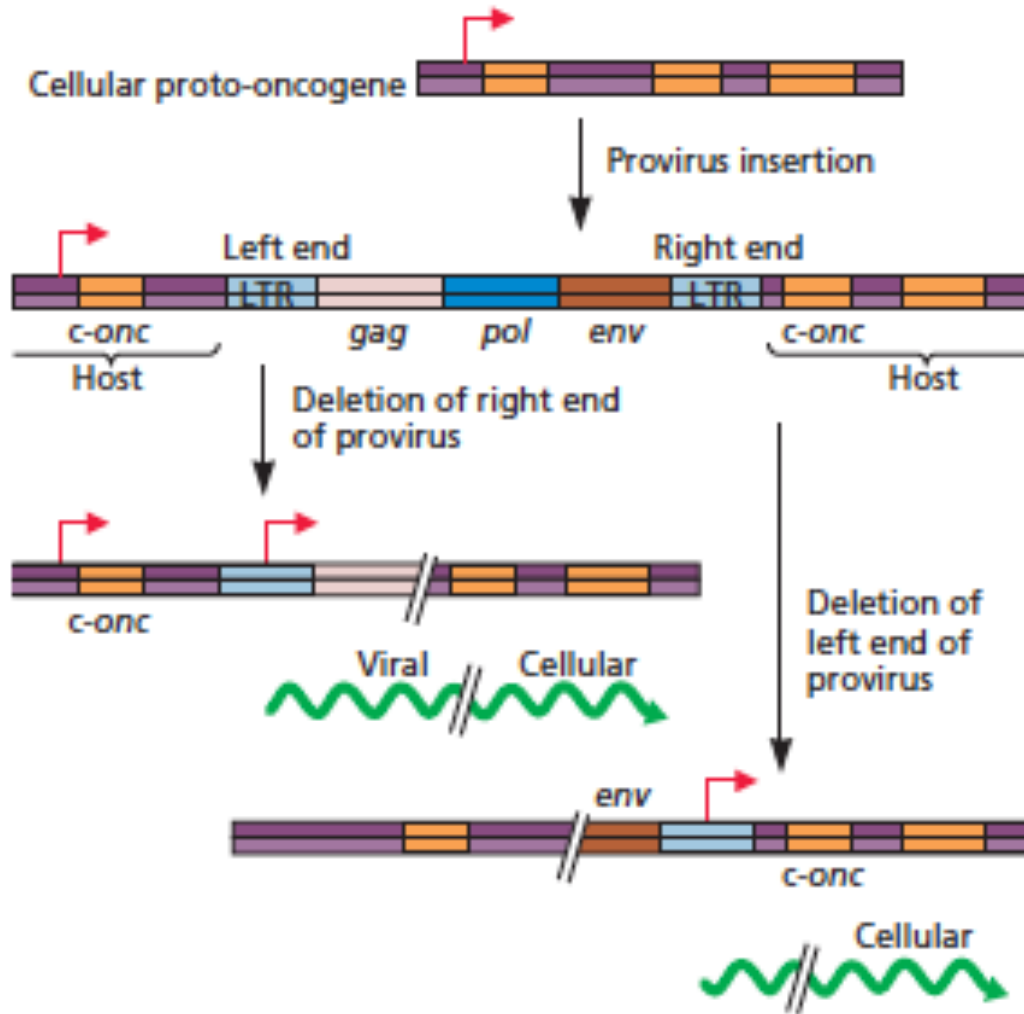

The first mechanism, promoter insertion, results in production of a chimeric RNA in which sequences transcribed from the proviral LTR are linked to cellular proto-oncogene sequences. If transcription originates from the left-end LTR, some viral coding sequences may be included. However, transcription from the right-end LTR seems to be more common, and in these cases the proviral left-end LTR has usually been deleted. Proviral integration often occurs within the cellular proto-oncogene, truncating cellular coding sequences and eliminating noncoding domains that may include negative regulatory sequences. Some chimeric transcripts formed in this way are analogous to the intermediates that give rise to oncogene capture by the transducing retroviruses. Indeed, it has been possible to isolate newly generated, oncogene-transducing retroviruses from tumors arising as a result of promoter insertion.

Slowly transforming retroviruses: insertional mutagenesis

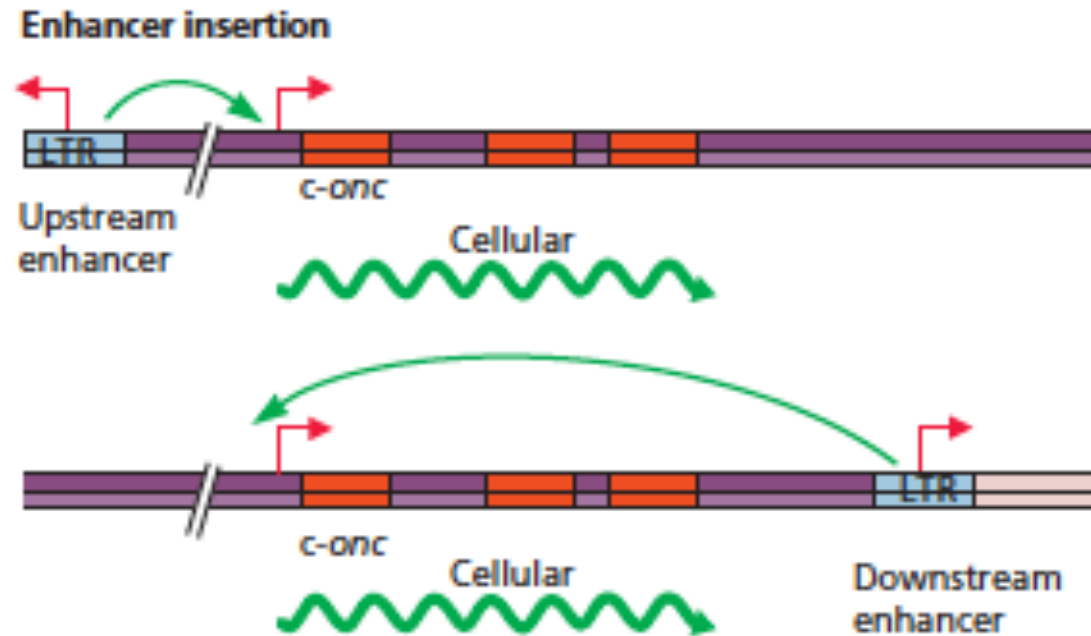

In the second type of insertional activation, enhancer insertion, viral and cellular transcripts are not fused. Instead, activation of the cellular gene is mediated by the strong viral enhancers, which increase transcription from the cellular promoter. Because enhancer activity is independent of orientation and can be exerted over long distances, the provirus need not be oriented in the same direction as the proto-oncogene, and may lie downstream of it.

DNA Tumor Viruses

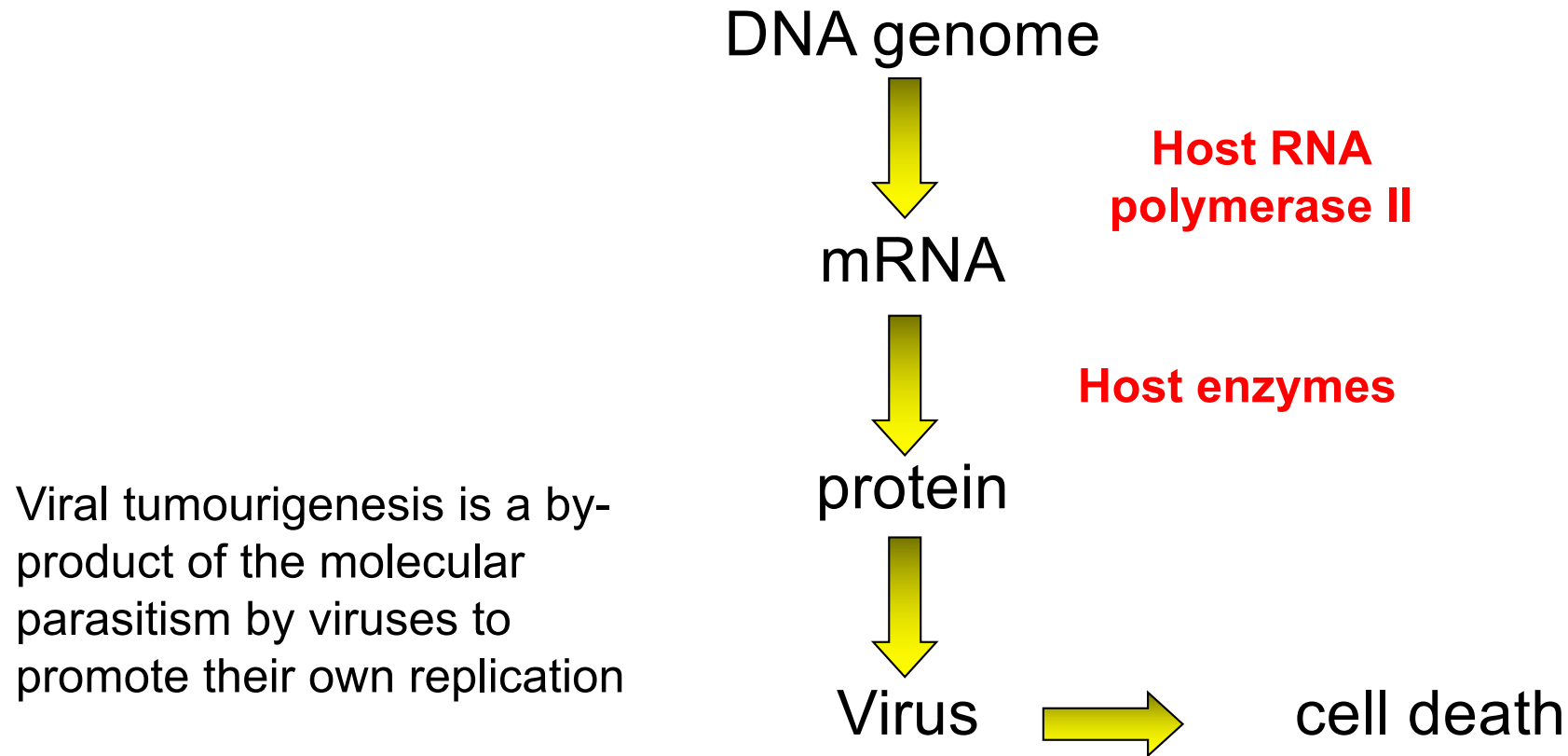

OR TRANSFORMATION

In transformation usually only **EARLY functions are expressed**

DNA virus expression timing

1 Early mRNAs synthesized prior to DNA replication

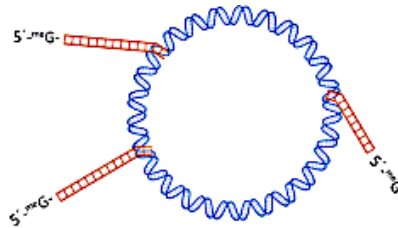

2 Early proteins expressed from early mRNAs

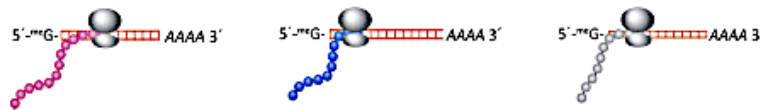

3 Early proteins reprogram cell metabolism and direct genome replication

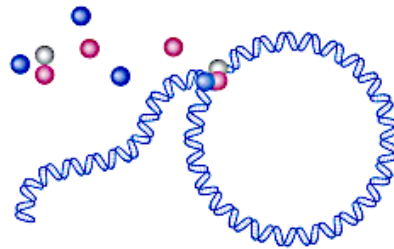

4 Late mRNAs synthesized after genome replication

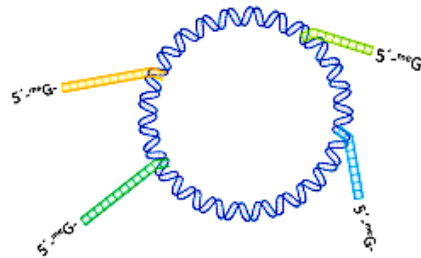

5 Late proteins expressed from late mRNAs

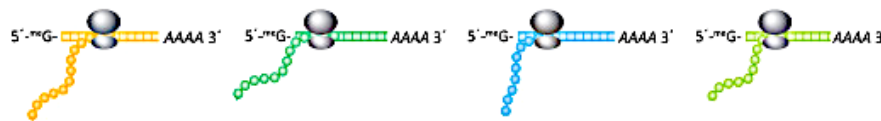

Upon uncoating, the genomes of DNA viruses are transcribed to produce an “early” set of mRNAs. Early mRNAs typically encode for proteins that modulate the host cell environment and/or are required for viral genome replication. After genome replication another set of mRNAs, the “late” mRNAs are expressed. Late genes encode structural proteins (and other proteins that are packaged within virions).

Early gene expression

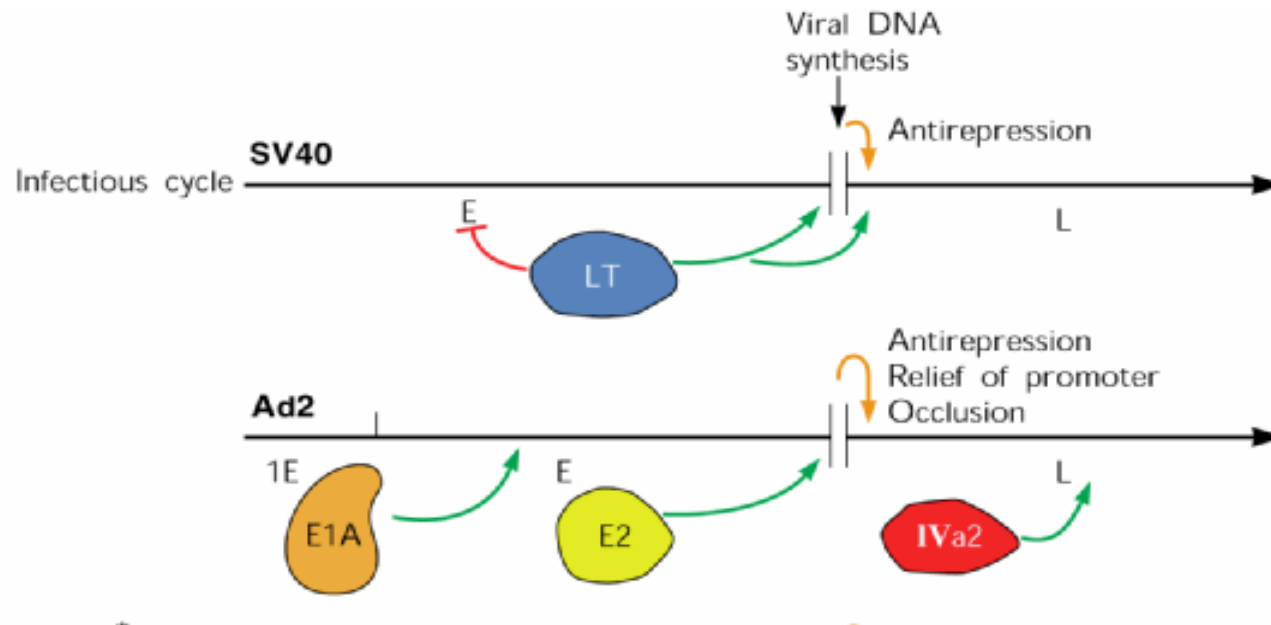

Trasformazione da virus a DNA

Table 7.5 Transforming proteins of DNA tumour viruses

Virus	Transforming protein(s)	Cellular target
Adenoviruses	E1A + E1B	Rb, p53
Polyomaviruses (SV40)	T antigen	p53, Rb
Papillomaviruses:		
BPV-1	E5	PDGF receptor
HPV-16, 18	E6	p53
	E7	Rb

A. Adenovirus

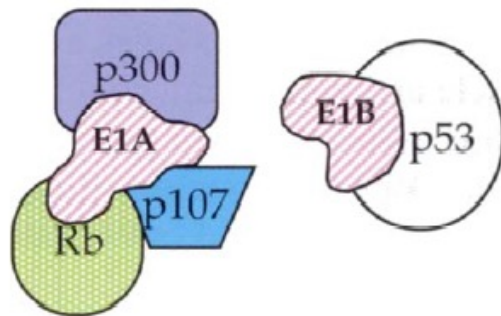

B. SV40

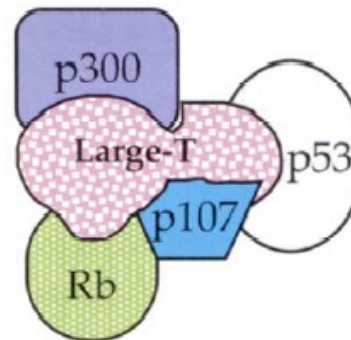

C. Papillomavirus

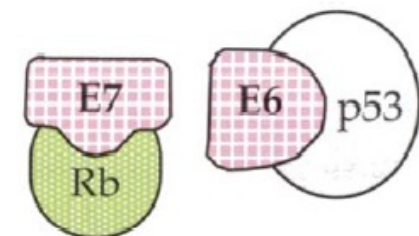

Trasformazione da virus a DNA

(virus tumorali a DNA)

Oncosoppressori

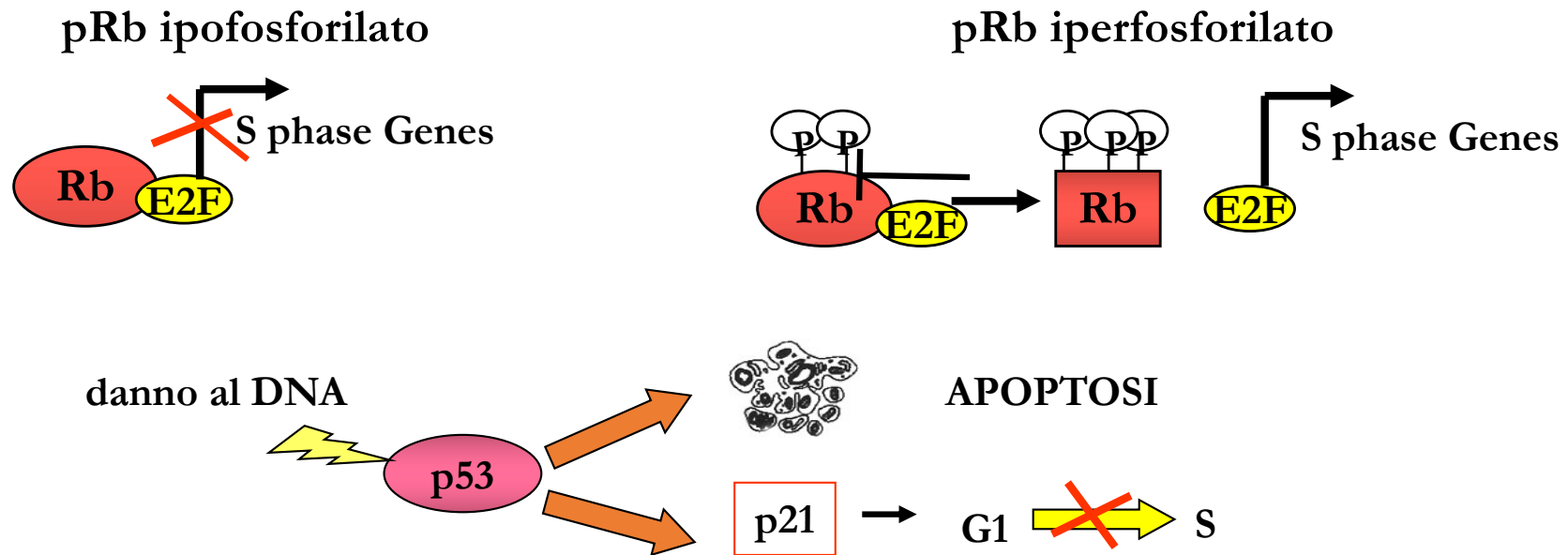

Normal cells

A

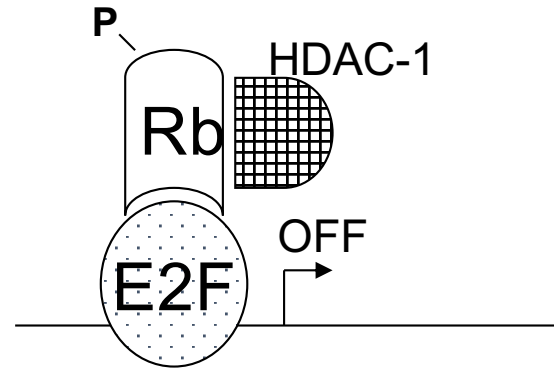

B

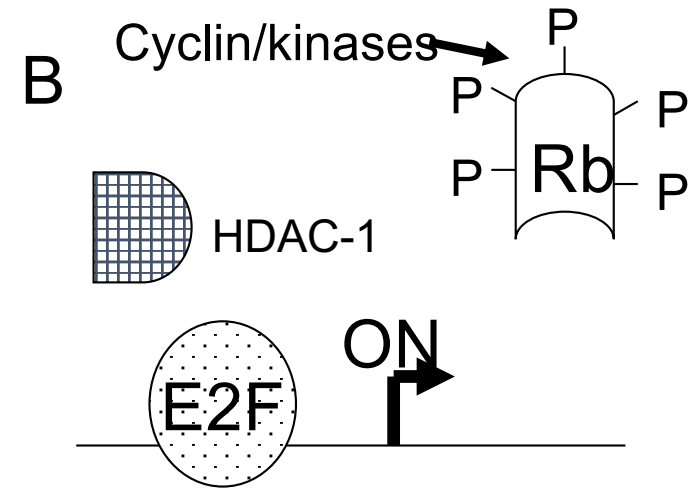

HPV-infected cells

C

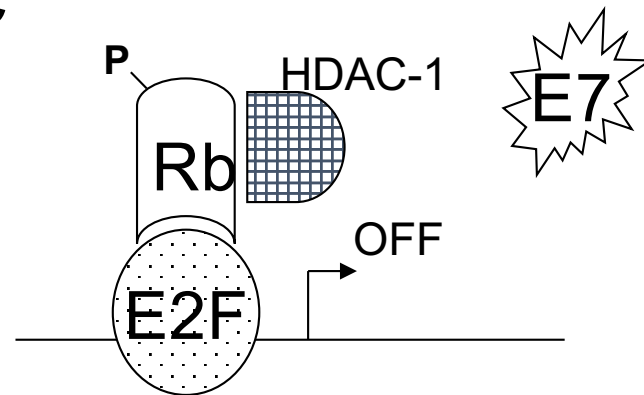

D

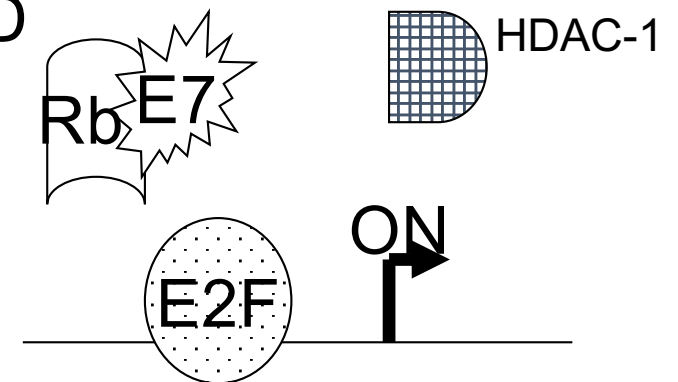

Permissive cells: Replication, lysis and death

Non-permissive cells: transformation. Usually DNA is integrated. Early functions only are expressed.
Control information, rather than structural proteins

SV40 life cycle, infection of permissive cells

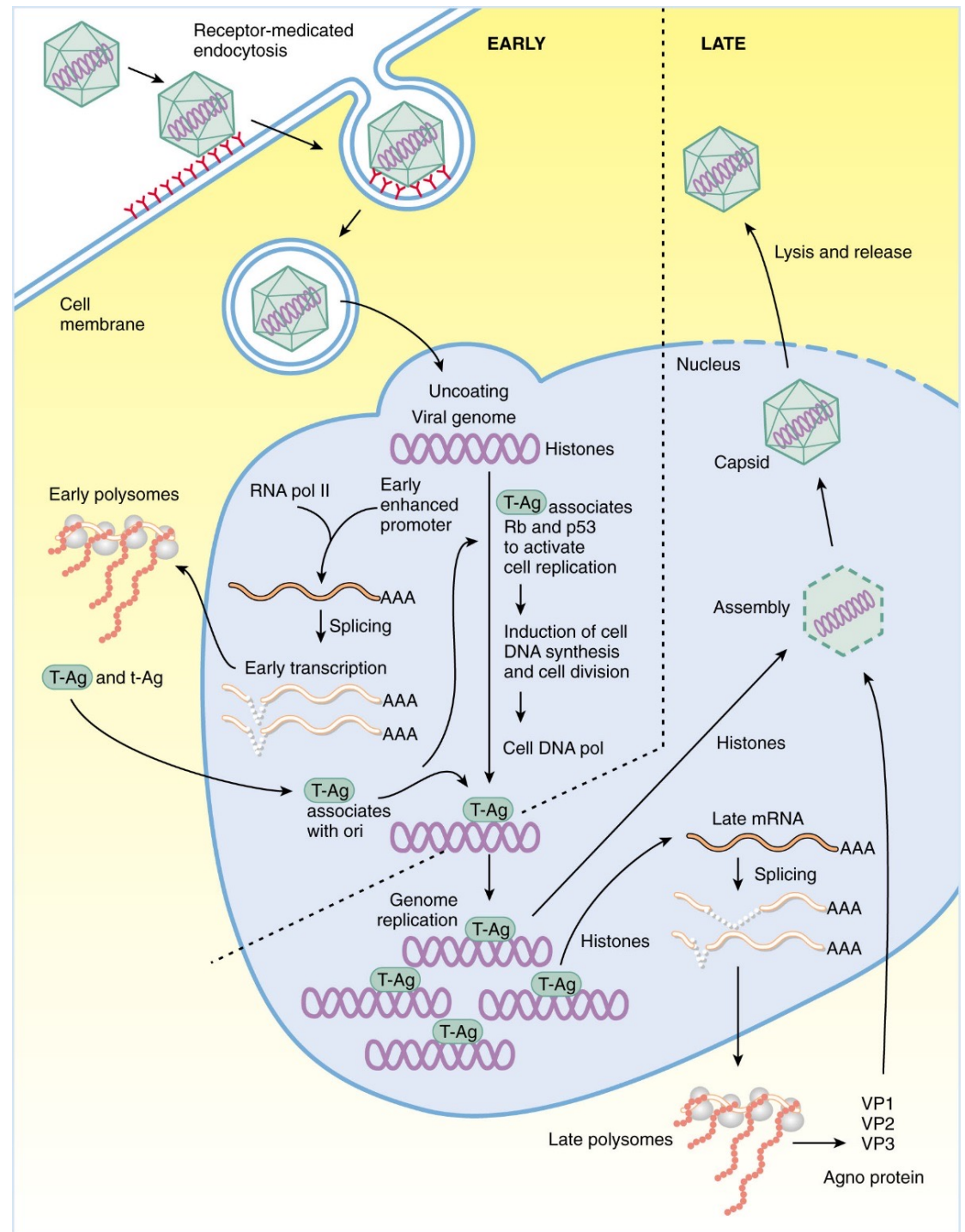

SV40 life cycle, infection of **non-permissive** cells

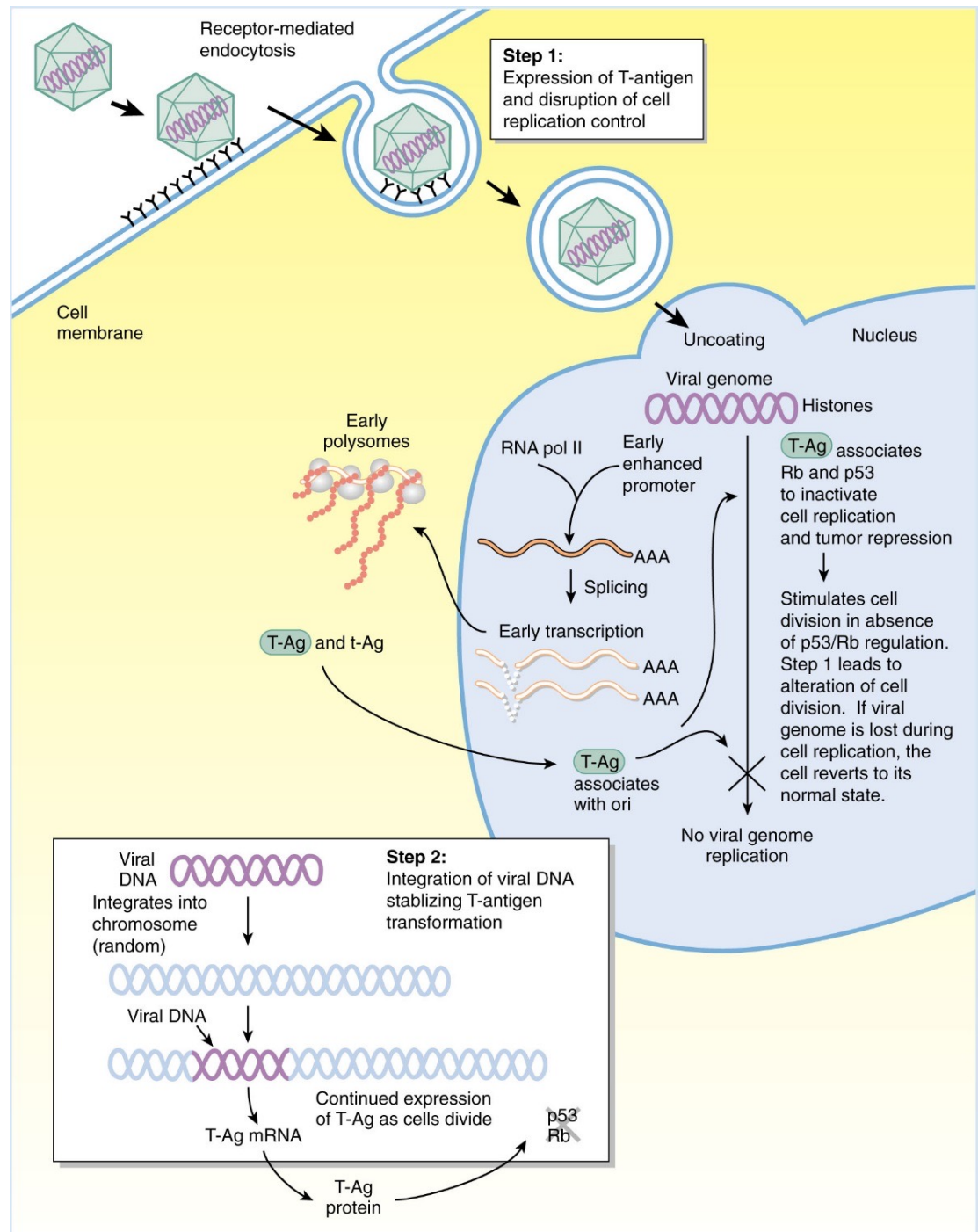

HPV life cycle

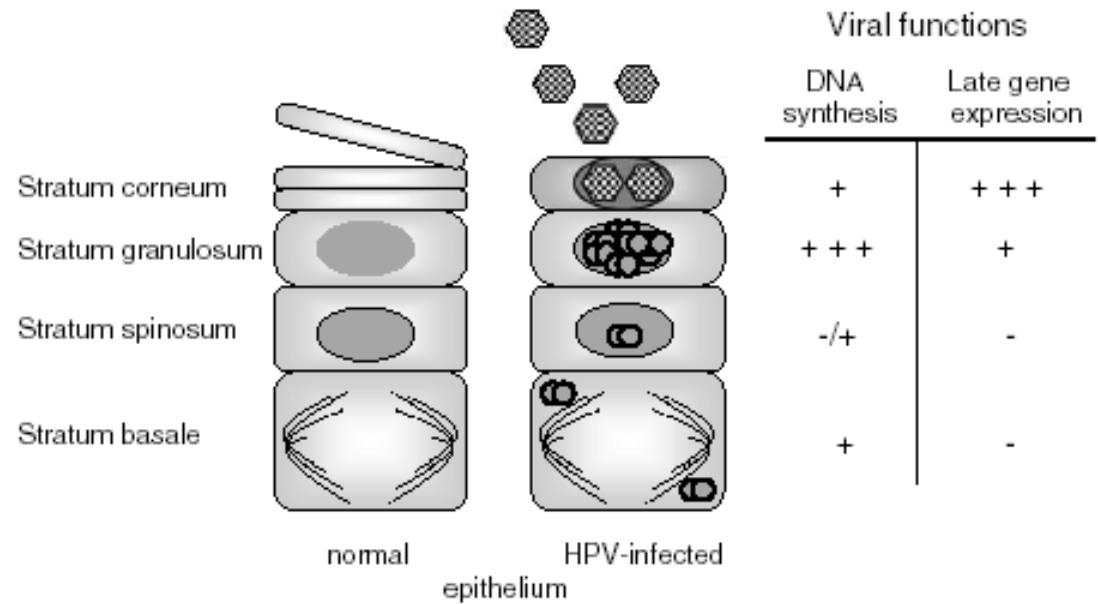
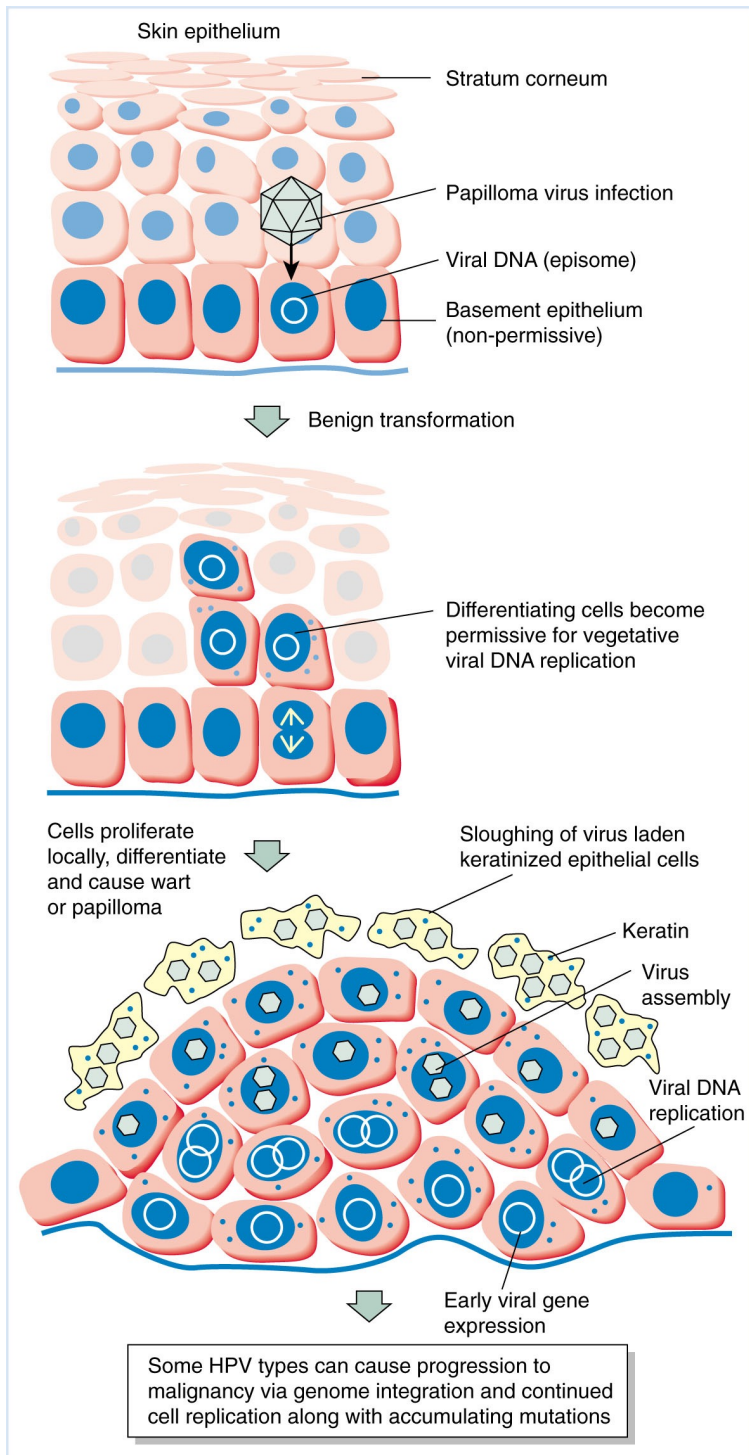

From Wagner and Hewlett *Basic virology* (2003) Blackwell Science Press