

Codice OPIS 2023-24

L88JNELD

**MECCANISMI CELLULARI E MOLECOLARI
DELLA RISPOSTA IMMUNE (1047783)**

SCIENZE BIOLOGICHE (30857)

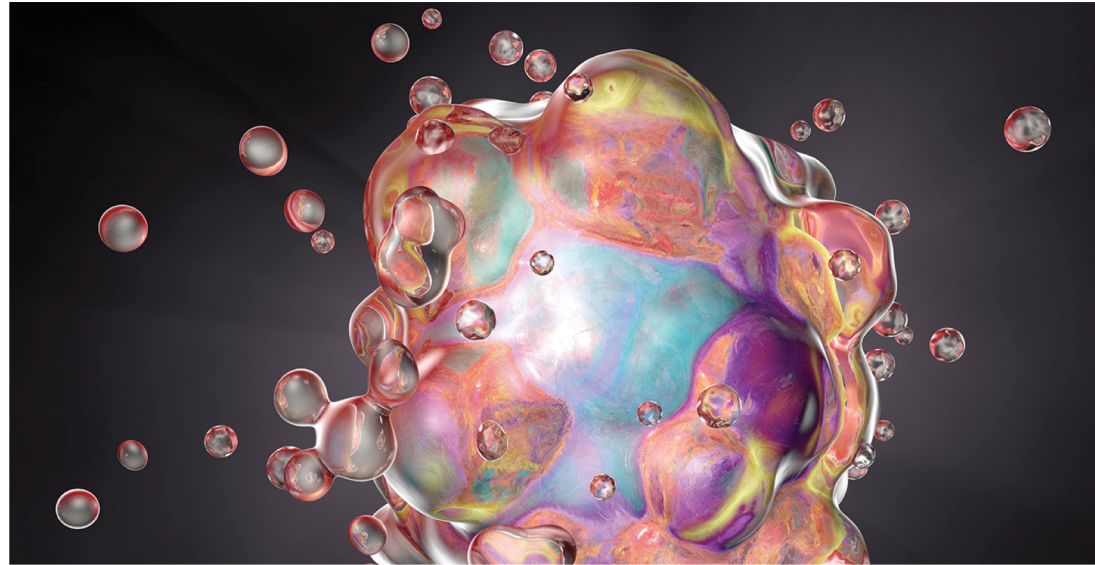
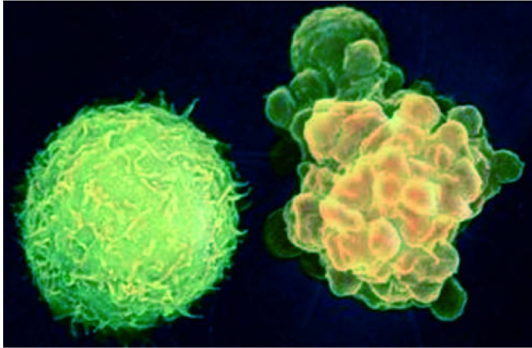

Morte cellulare e sistema immunitario

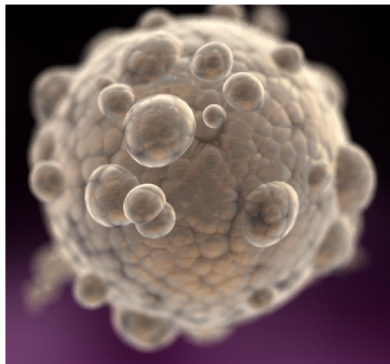

Final stage of apoptosis

White blood cell

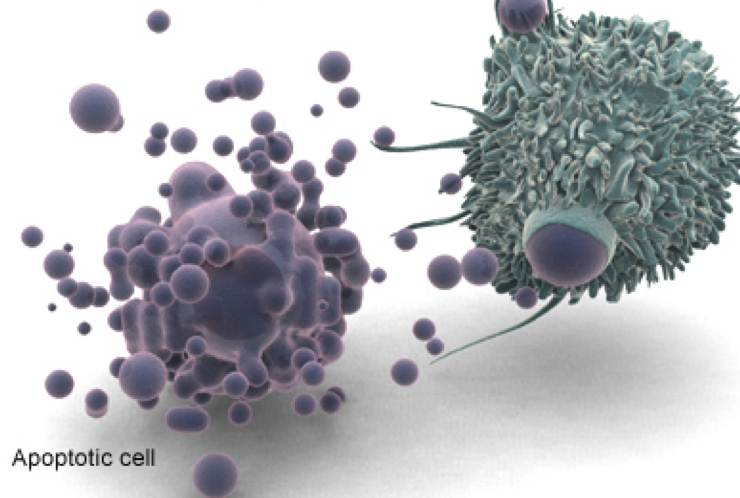

Apoptotic cell

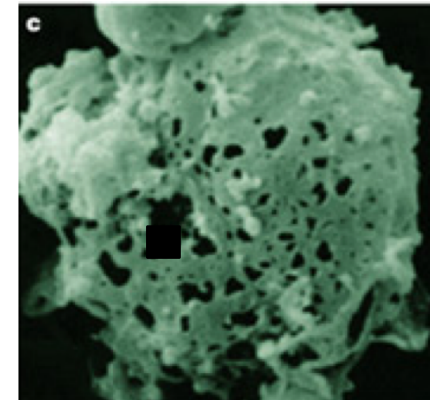

Fase di declino delle risposte linfocitarie

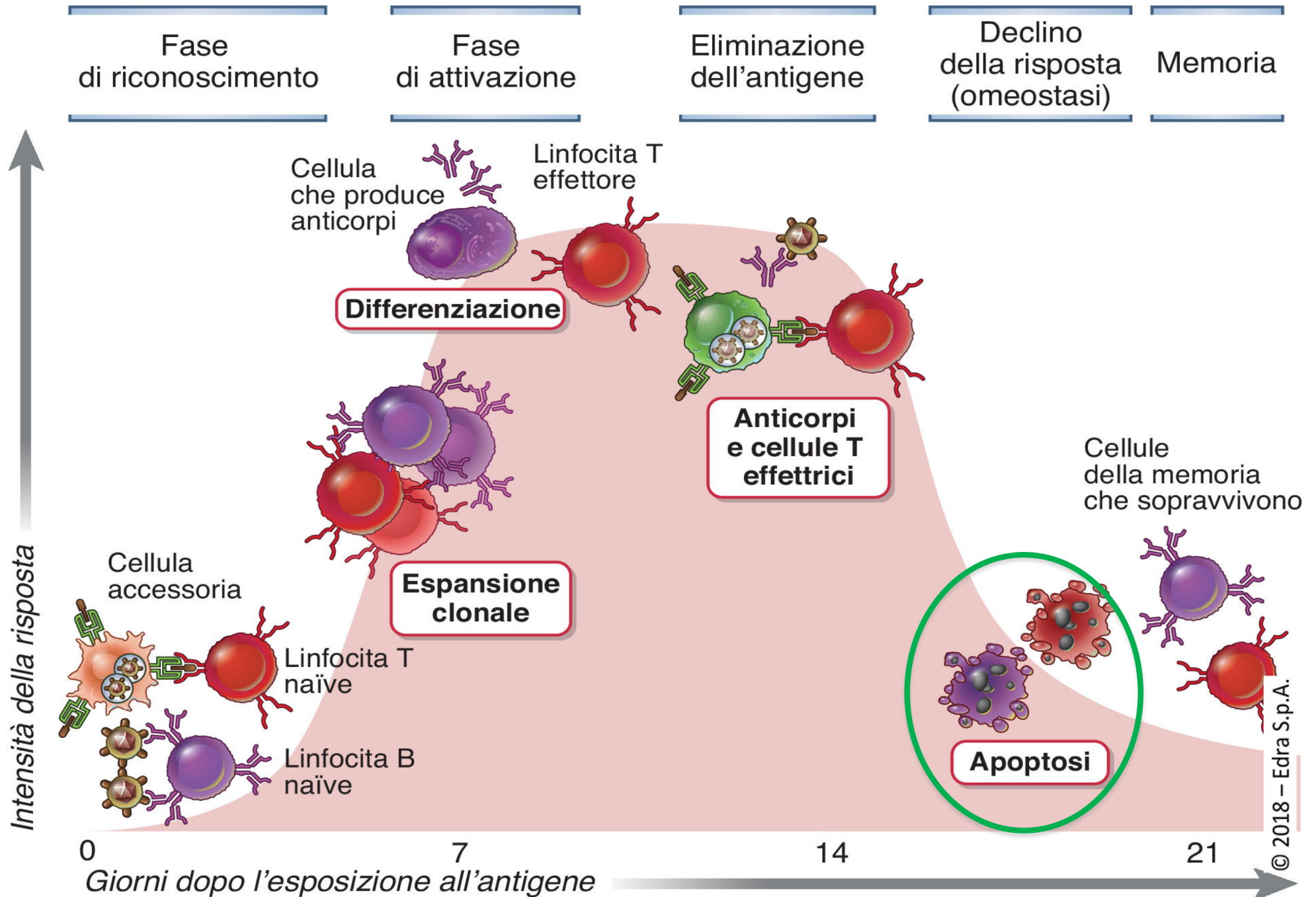

Cell death in immunological processes

a Contraction of effector cell populations

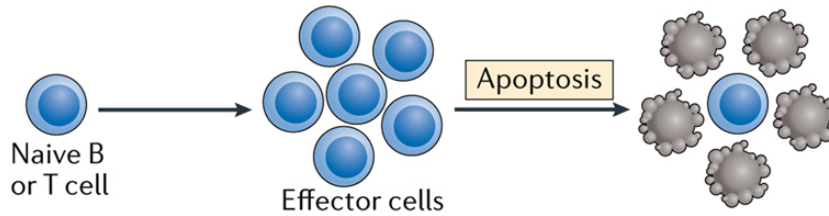

b Lymphocyte development

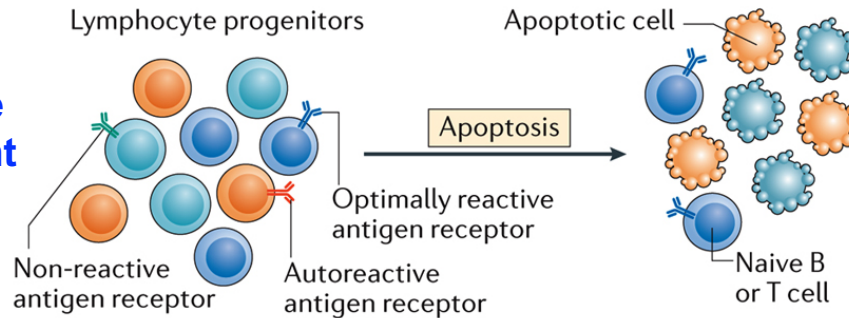

a| When naive lymphocytes encounter pathogens, they proliferate and are activated to combat the pathogens. These activated lymphocytes will subsequently die after the pathogens have been removed. A similar situation can be found with **neutrophils** during inflammation (not shown). That is, when our body is infected by bacteria, neutrophil populations expand, and neutrophils are activated to phagocytose bacteria, but they quickly undergo apoptosis after the infection has been cleared.

b| During lymphocyte development, a large number of lymphocyte progenitors that express antigen receptors with a high affinity for self-antigens or that cannot respond to antigens are eliminated by apoptosis. The lymphocytes that survive this stage of development remain in the periphery and form the naive T cell and naive B cell compartments.

c Elimination of infected or transformed cells by apoptosis

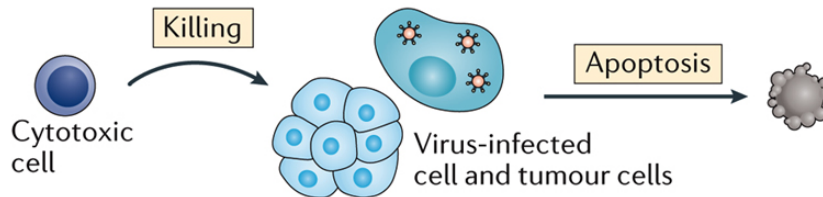

c| Cytotoxic T lymphocytes and natural killer cells recognize virus-infected, bacteria-infected and transformed cancer cells, and induce these cells to die by apoptosis.

d Elimination of infected cells by necrosis

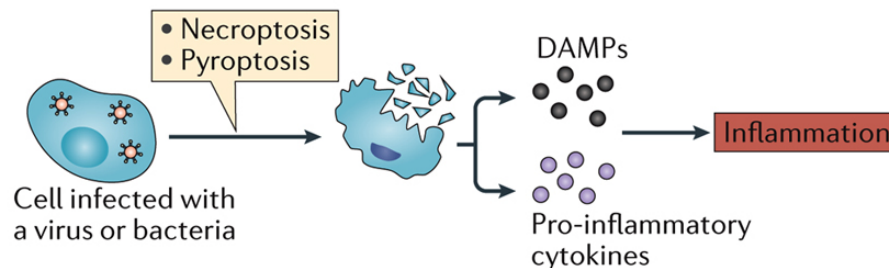

d| Bacteria-infected cells, particularly phagocytes, often undergo necrosis to prevent bacteria from proliferating further inside the cell. Unlike apoptosis, **necrosis is an inflammatory form** of cell death and can lead to further tissue inflammation. DAMPs, damage-associated molecular patterns.

Fase di contrazione della risposta linfocitaria

© 2022 Edra SpA per uso didattico

Mancanza di:
-Antigene
-Costimolazione
-citochine (IL2)

Espressione di
recettori costimolatori
inibitori
-CTLA4
-PD1

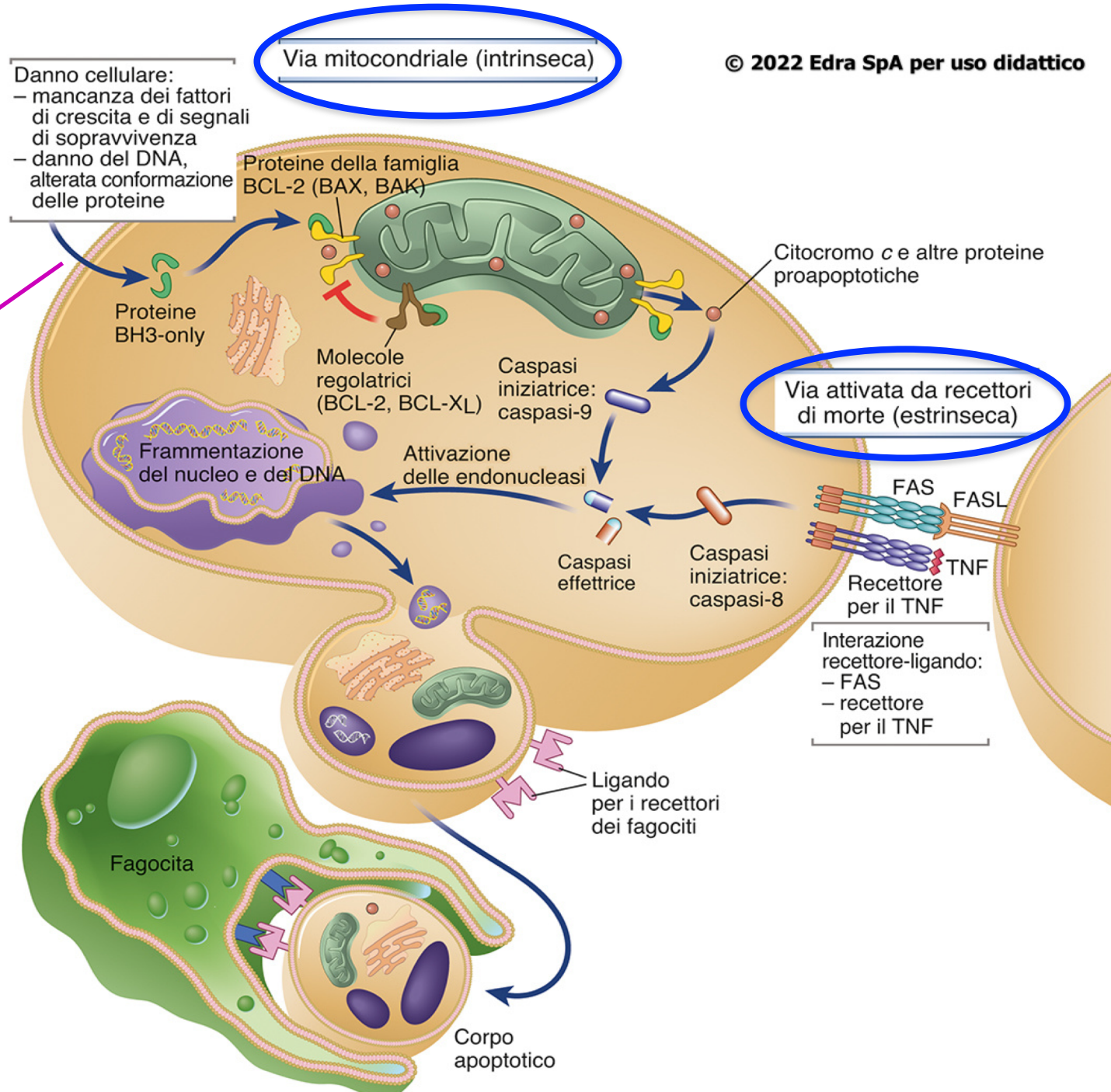

Vie intrinseca ed estrinseca dell'apoptosi

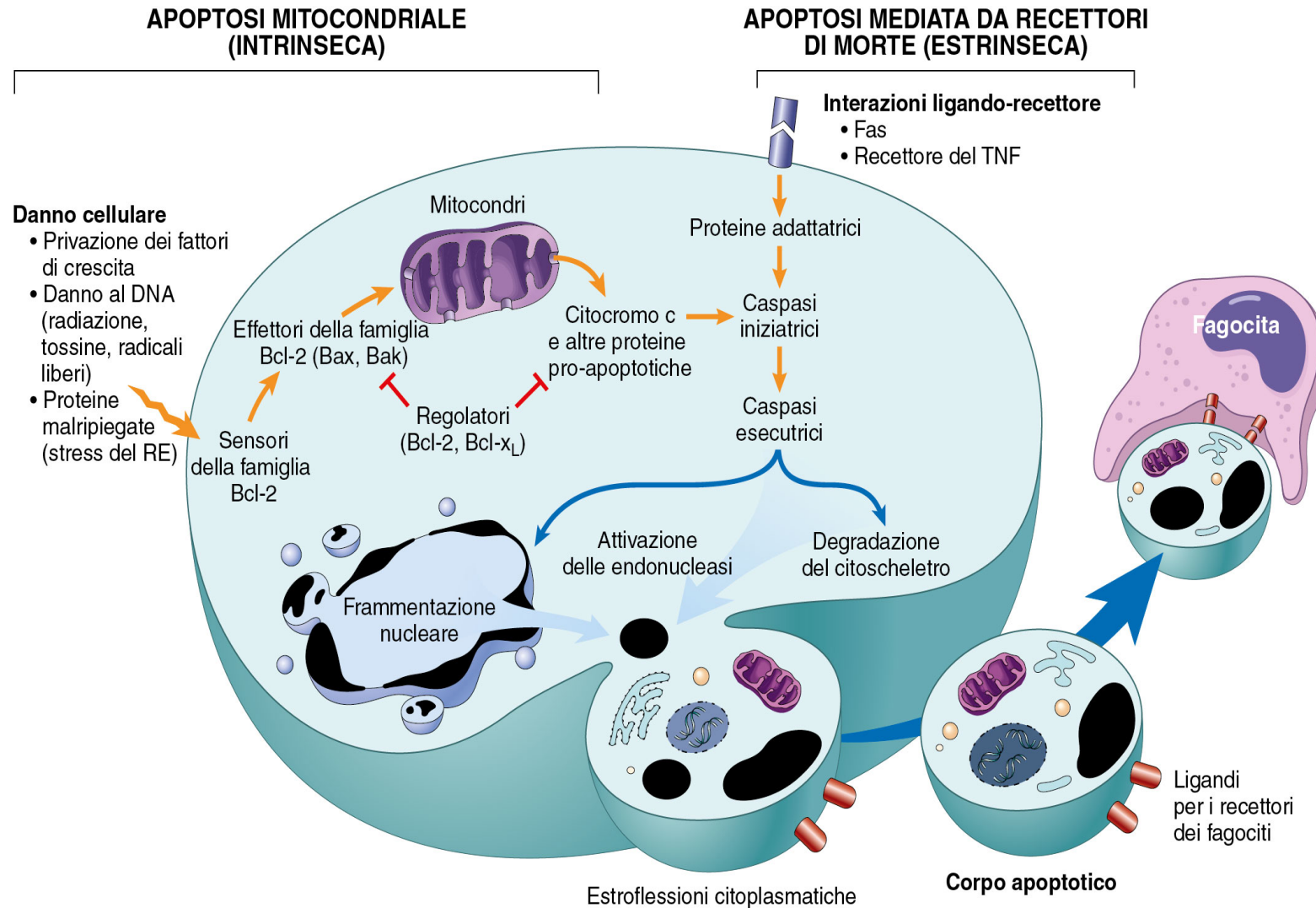

Meccanismi di apoptosi. Le due vie di induzione dell'apoptosi differiscono nei meccanismi di attivazione e regolazione, ma convergono nell'attivazione delle caspasi. Nella via mitocondriale, lo sbilanciamento nelle proteine della famiglia Bcl-2, che regolano la permeabilità mitocondriale, causa la fuoriuscita di varie sostanze dai mitocondri, attivando le caspasi. Nell'apoptosi indotta dai recettori di morte, l'attivazione di recettori presenti sulla membrana plasmatica induce il reclutamento di proteine adattatrici per assemblare complessi che trasducono segnali di morte, attivando le caspasi, con lo stesso risultato finale.

Cell proliferation = cell death → homeostasis

proliferation

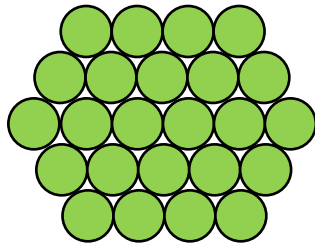

Cell death

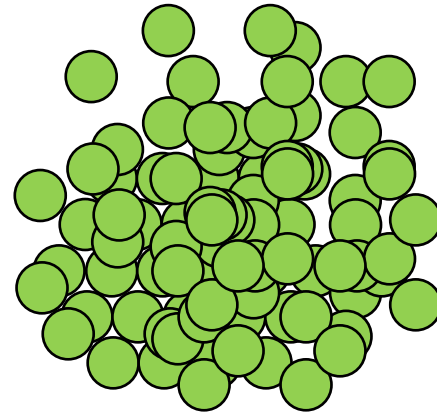

disorders of cell accumulation

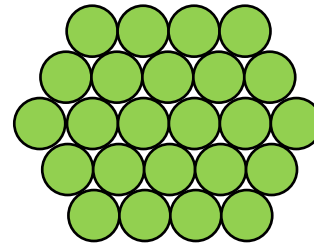
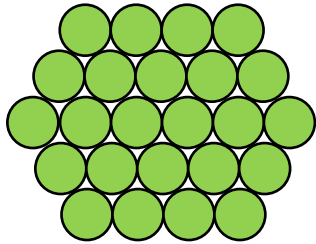

homeostasis

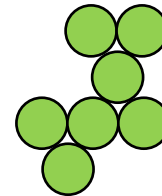
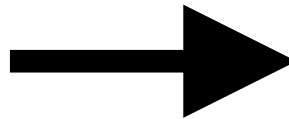
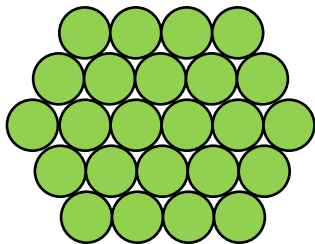

disorders of cell loss

time



Caenorhabditis elegans: modello di studio per l'apoptosi

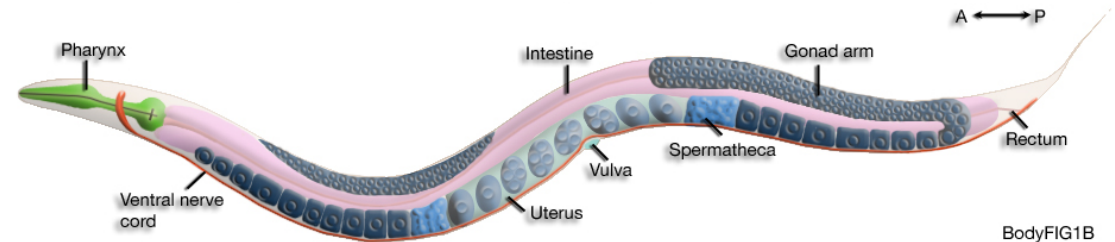

	AB Ectoderm Nervous system	MS mesoderm muscle	E gut endoderm	C misc	D muscle	P4 germ cells
survivors	606	252	34	47	20	variable
deaths	116	14	0	1	0	variable

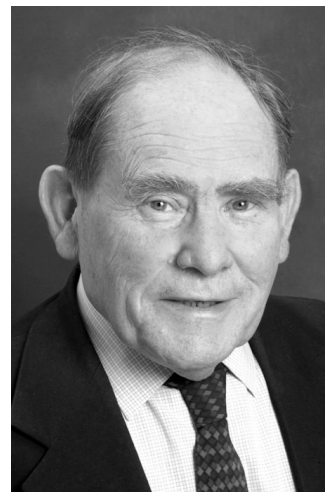
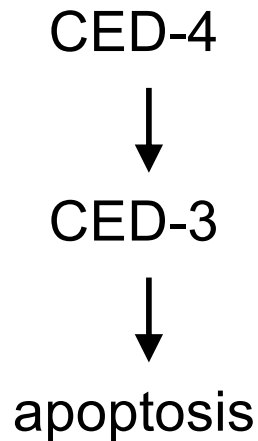

Brenner S,



Sulston J,



Horvitz HR

Nobel prize in Physiology or Medicine (2002)

Modificazioni morfologiche di una cellula apoptotica e di una cellula necrotica

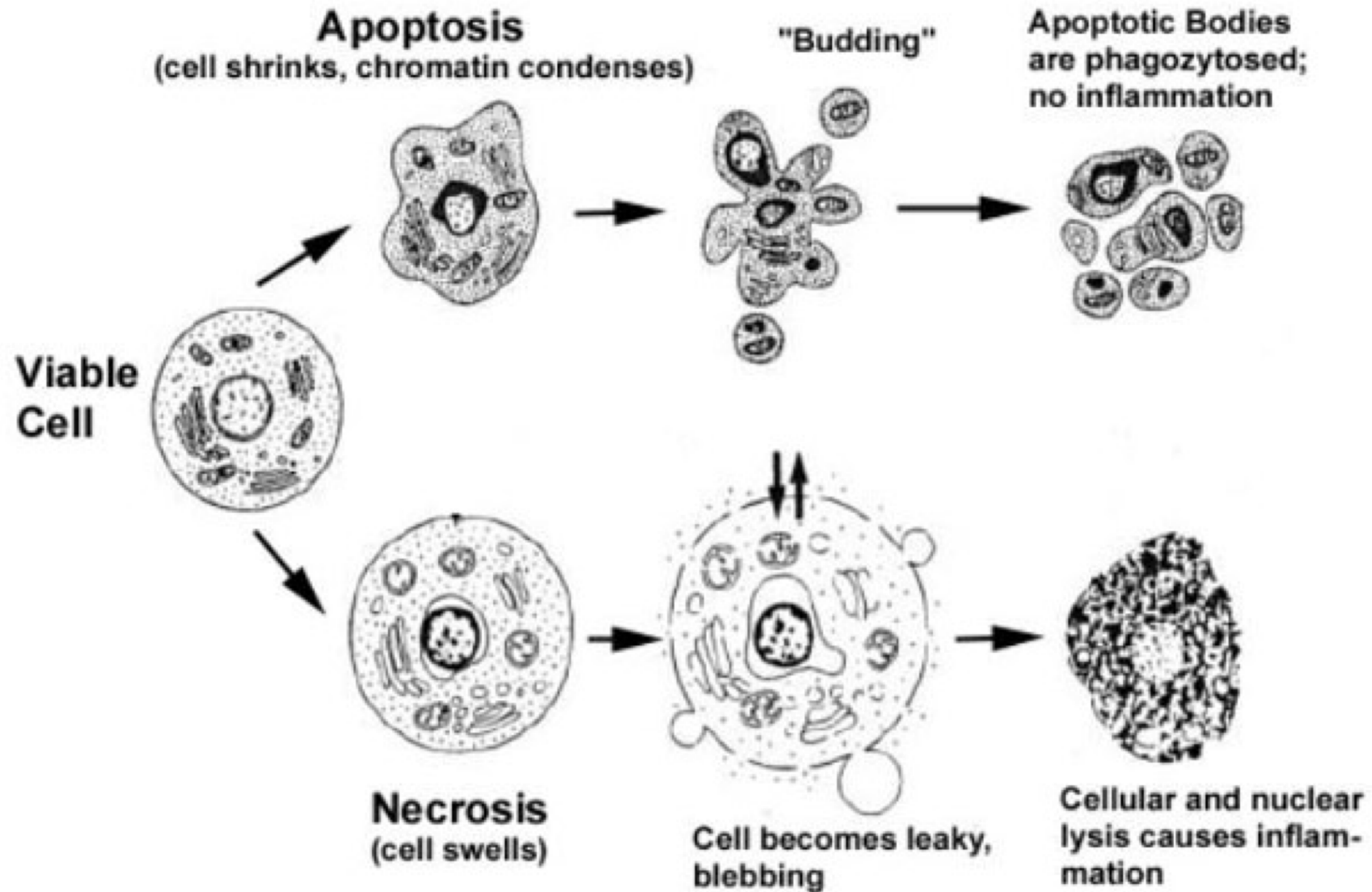

Apoptosi

- L'apoptosi è un processo attivo e altamente controllato che gioca un ruolo importante nello sviluppo degli organismi multicellulari e nella regolazione della popolazione cellulare nei tessuti in condizioni fisiologiche e patologiche.
- Il termine fu introdotto nel 1972 da Kerr, Currie e Wyllie per descrivere una serie di modificazioni morfologiche che accompagnavano la morte cellulare in diversi tessuti.
- La parola ha origini greche e indica “caduta” (riferita a quella delle foglie o dei petali dei fiori). Il termine è stato scelto perchè sottolinea che tale forma di morte cellulare è un meccanismo naturale, necessario e caratteristico del ciclo vitale degli organismi.
- Gli stimoli includono il signaling innescato dai recettori della superficie cellulare, mancanza di fattore di crescita, ipossia, danno al DNA, infezioni virali, agenti chemioterapici
- Meccanismo coinvolto in molti eventi fisiologici: embriogenesi, differenziazione, omeostasi, invecchiamento, rimozione di cellule difettose e/o dannose
- Alterazioni del processo causano una varietà di disturbi patologici: malattie neurodegenerative, immunodeficienza, malattie autoimmuni e cancro

APOPTOSI



Processo **attivo** caratterizzato da collasso delle strutture cellulari per digestione proteolitica selettiva con:

- aumento della densità cellulare
- disintegrazione del citoscheletro
- frammentazione del genoma
- formazione di corpi apoptotici
- **assenza di infiammazione** riducendo il danno tissutale

NECROSI

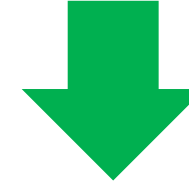

Processo accidentale indotto da lesioni/trauma e caratterizzato da:

- aumento del volume cellulare
- rottura delle membrane degli organelli e membrana plasmatica
- rilascio del contenuto cellulare nello spazio esterno
- **induzione di infiammazione**

Schematic view of a nucleus in a cell undergoing apoptosis

Healthy

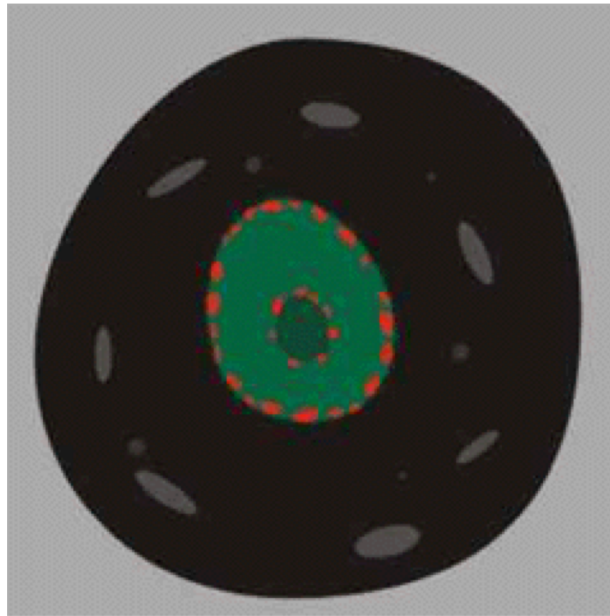

Early apoptosis

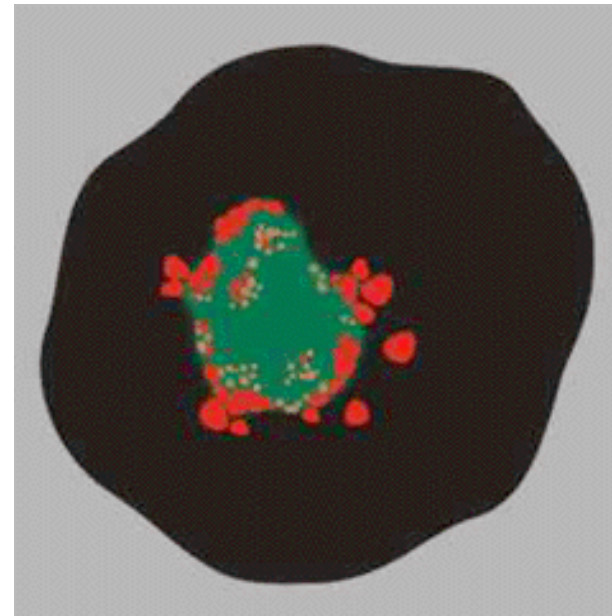

Advanced apoptosis

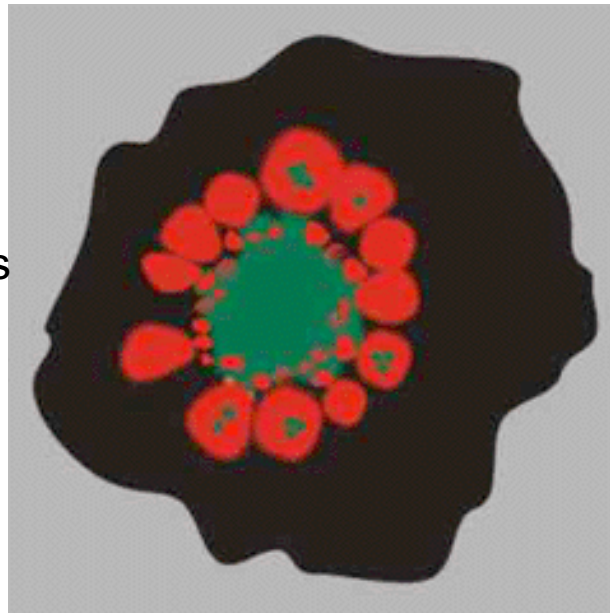

Late apoptosis

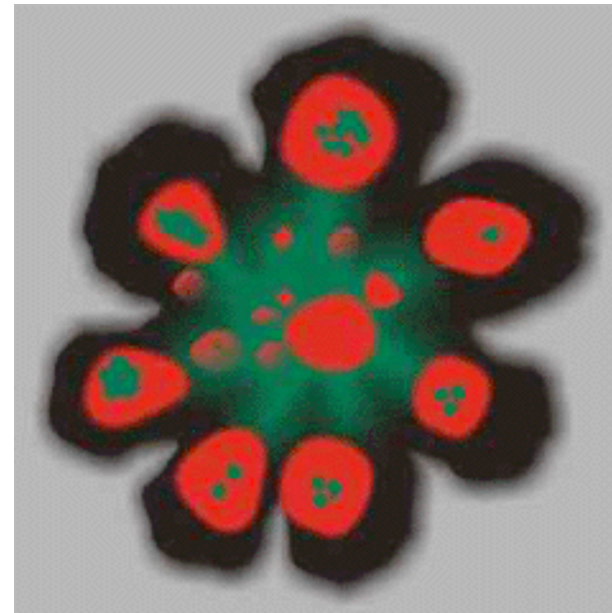

Caratteristiche biochimiche dell'apoptosi

- **Esposizione di fosfatidilserina sulla superficie cellulare**
- **Frammentazione endonucleosomica del DNA genomico**
- **Taglio proteolitico del citoscheletro e delle proteine nucleari**

Colorazione della membrana plasmatica con annessina V come metodo di rilevazione di eventi apoptotici precoci

Annessina V lega specificamente la fosfatidilserina

Phosphatidylserine "Flip"

Scramblase(XKR8)

phosphatidylserine redistribution

membrane asymmetry

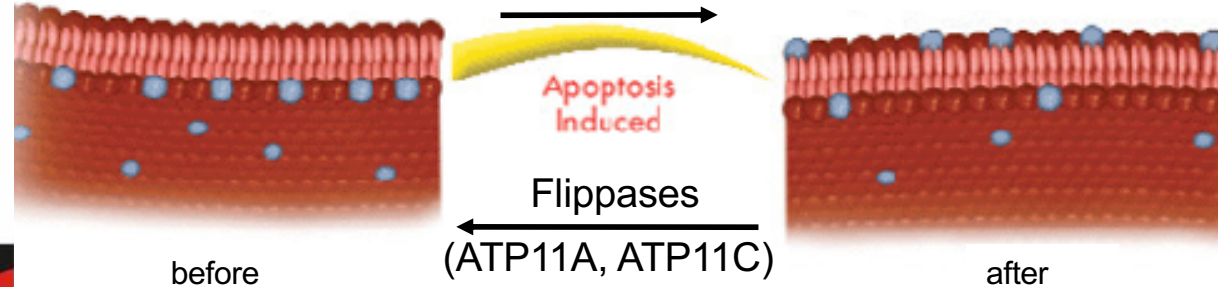

- Phospholipid
- Phosphatidylserine
- Annexin with a green fluorescent label

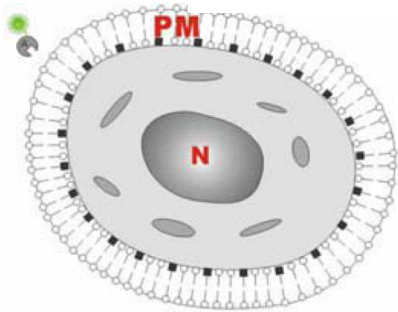

Normal, healthy cell

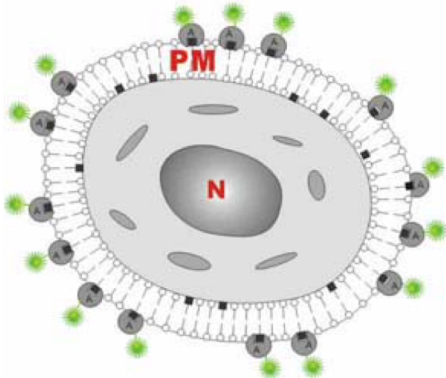

Apoptotic cell

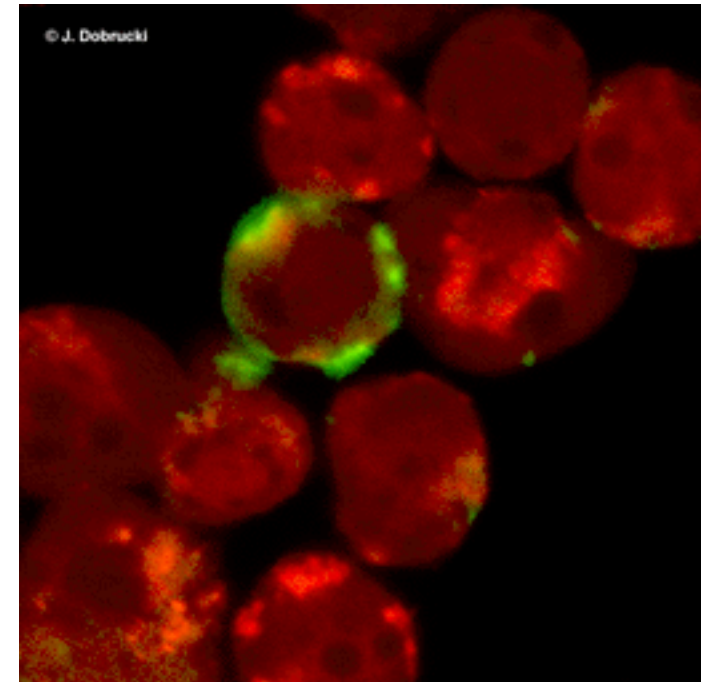
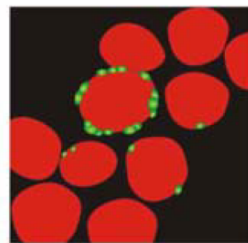

microscope image

Colorazione con annessina V e ioduro di propidio per discriminare le cellule apoptotiche dalle cellule necrotiche

Eat me signals

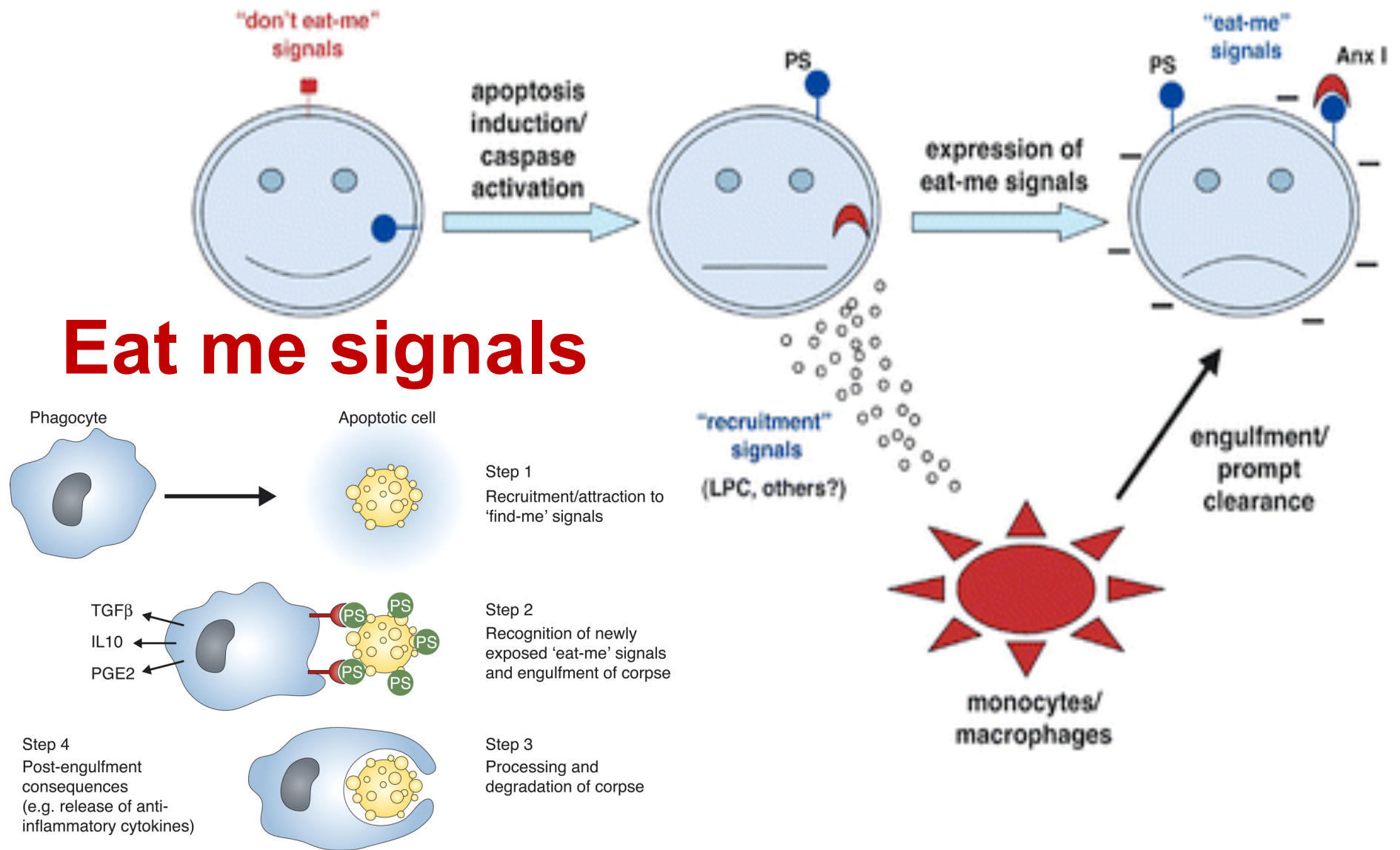

Different steps involved in efficient apoptotic cell clearance. The find-me signals (such as low levels of nucleotides ATP and UTP, fractalkine, lysophosphatidylcholine, or sphingosine 1-phosphate) released by apoptotic cells help attract motile phagocytes to the proximity of the cell undergoing apoptosis. The phagocytes then use engulfment receptors on their surface to engage eat-me signals on apoptotic cells. For clarity, only the PtdSer on the apoptotic cells engaged by cognate receptors is depicted. Engagement of the engulfment receptors (linked to PtdSer recognition) has been shown to stimulate release of antiinflammatory cytokines such as TGF- β , IL-10, and prostaglandin E2 (PGE2). The intracellular signaling induced within the phagocyte by the ligand-receptor interactions leads to cytoskeletal rearrangements and internalization of the dying cell. The phagocyte processes the engulfed corpse through a series of steps, and proper digestion seems to be important for continued uptake of other dying cells by phagocytes

Attivazione del processo apoptotico

Pathway estrinseco

Legame dei membri della famiglia del TNF:

-TNF -Linfotossina - FasL -TRAIL etc

ai rispettivi recettori

-TNFR1 -Fas -TRAILR etc*



Formazione del **DISC**
(Death-Inducing Signaling Complex)
dopo reclutamento di molecole
adattatrici (es. **FADD e TRADD**) e
delle pro-caspasi 8 (o 10)

* Death receptors:

- TNFR1
- Fas
- DR3
- TRAILR
- DR5
- DR6

**Attivazione delle caspasi iniziatrici
e poi delle caspasi effettrici**

Pathway intrinseco

“Stress or danger conditions”



(sensori interni)

esempio **p53**



Propagazione del segnale attraverso i
membri proapoptotici della famiglia
Bcl-2 (**Bid; Bad; Bax; Bak**)



Aumento della permeabilità della
membrana mitocondriale esterna

rilascio di
citocromo c

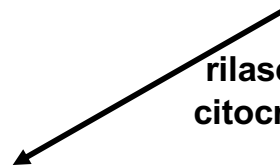

Pathways molecolari dell'apoptosi

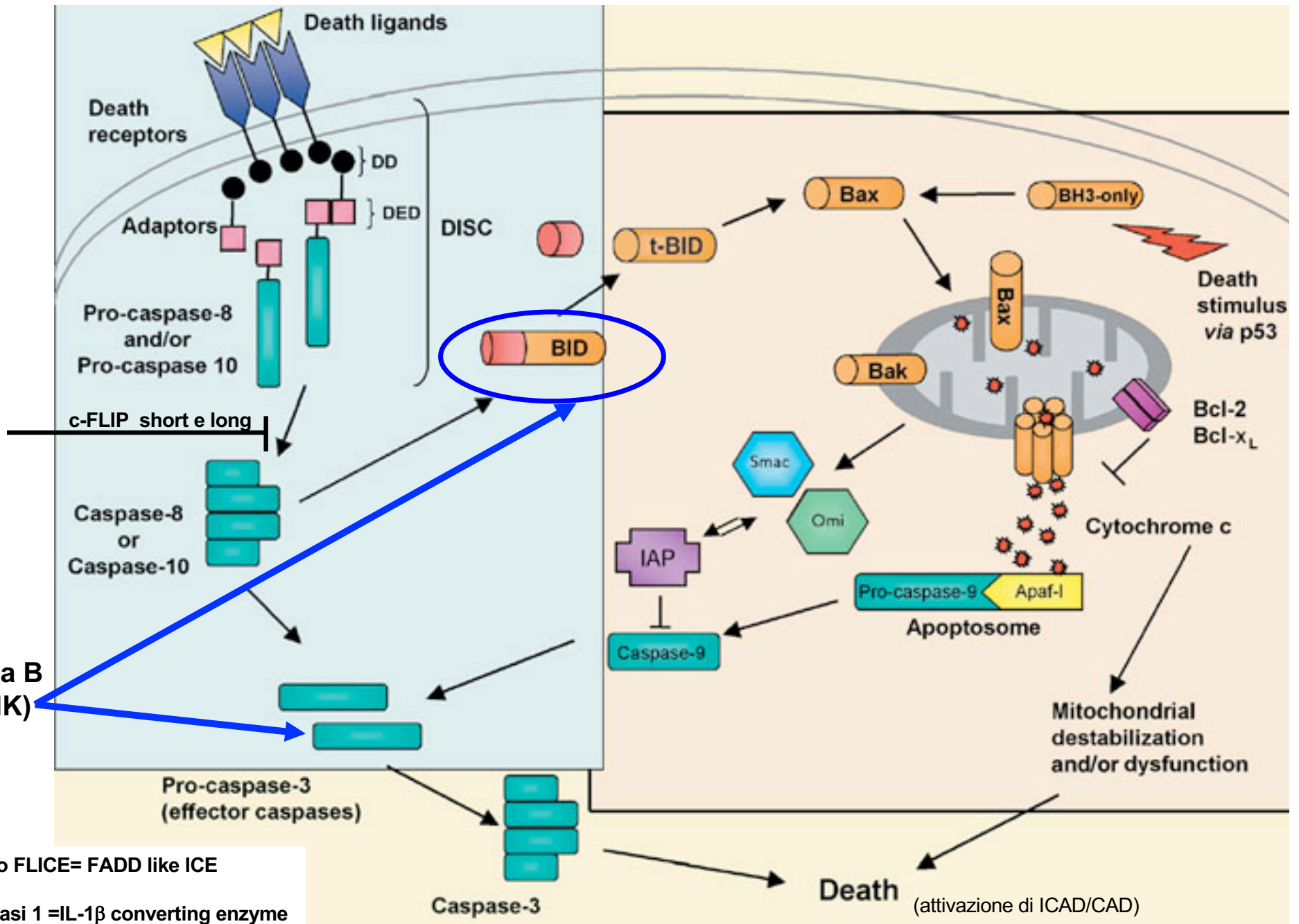

Caspi 8 o FLICE= FADD like ICE

ICE o caspi 1 =IL-1 β converting enzyme

FLIP= FLICE-like inhibitory protein

The two major apoptotic pathways

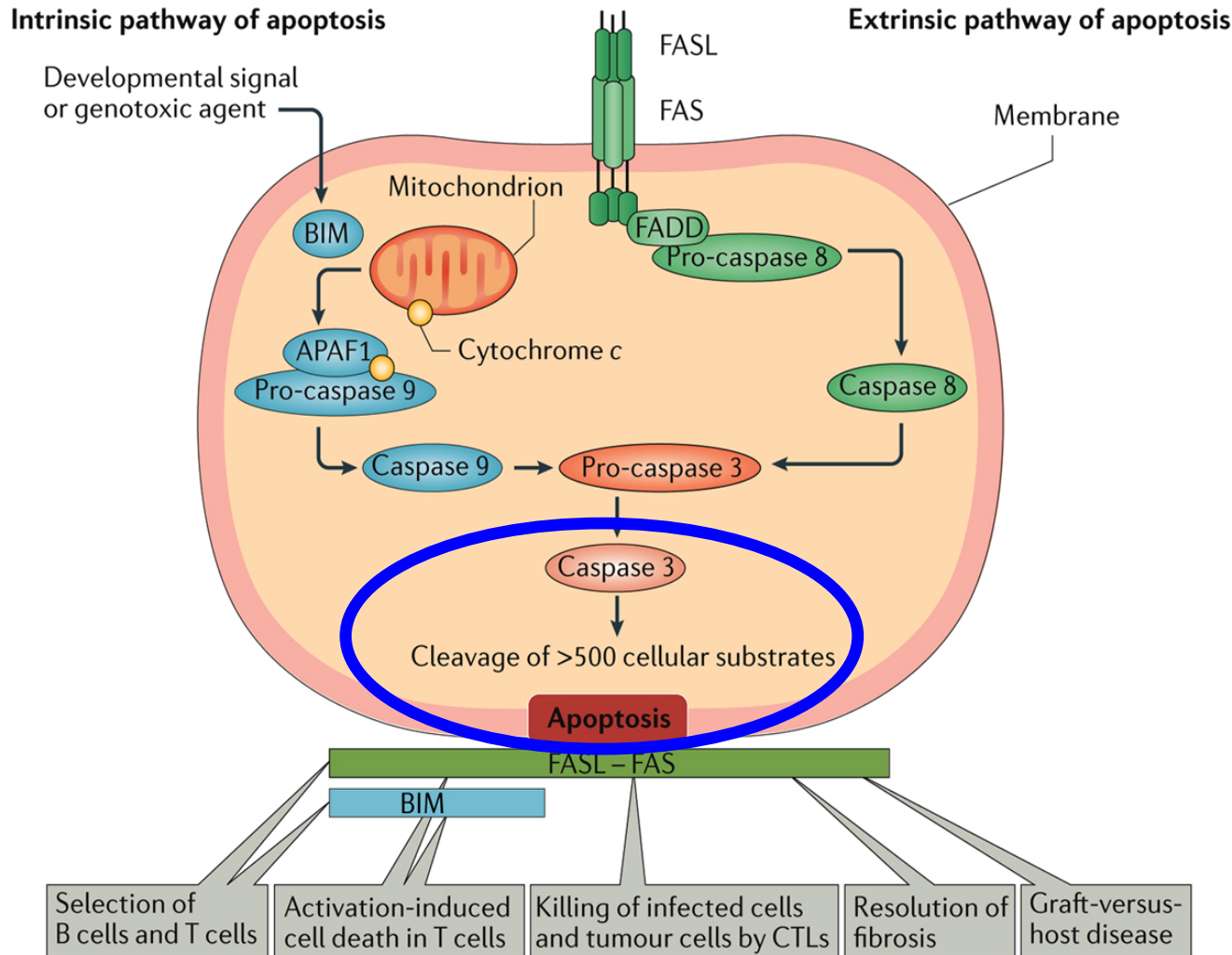

In the **extrinsic pathway** of apoptosis, a death-inducing factor such as FAS ligand (FASL) binds its receptor (FAS) and recruits the adaptor FAS-associated death domain protein (FADD) and pro-caspase 8 to form the death-inducing signalling complex (DISC). The cleavage and activation of pro-caspase 8 in the DISC then activates a downstream caspase cascade that typically involves caspase 3.

In the **intrinsic pathway** of apoptosis, a developmental programme or genotoxic agent activates a B cell lymphoma 2 homology 3 (BH3)-only protein, such as BIM, which stimulates the release of cytochrome c from mitochondria. Cytochrome c promotes the assembly of the apoptosome, which is a heptameric complex that comprises apoptotic protease-activating factor 1 (APAF1), pro-caspase 9 and cytochrome c. Mature caspase 9 generated by the apoptosome then cleaves pro-caspase 3 to form mature active caspase 3.

Nagata S and Tanaka M. 17: 333–340 (2017)

Nature Reviews | Immunology

Thus, both the extrinsic and intrinsic apoptotic pathways lead to the activation of caspase 3, which cleaves more than **500 cytoplasmic proteins** to induce apoptotic cell death. The intrinsic and extrinsic pathways of apoptosis are involved in various immunological processes, including the selection of lymphocytes, activation-induced cell death in T cells, the killing of infected cells and tumour cells, the resolution of fibrosis and graft-versus-host disease. CTL, cytotoxic T lymphocyte.

Death receptors

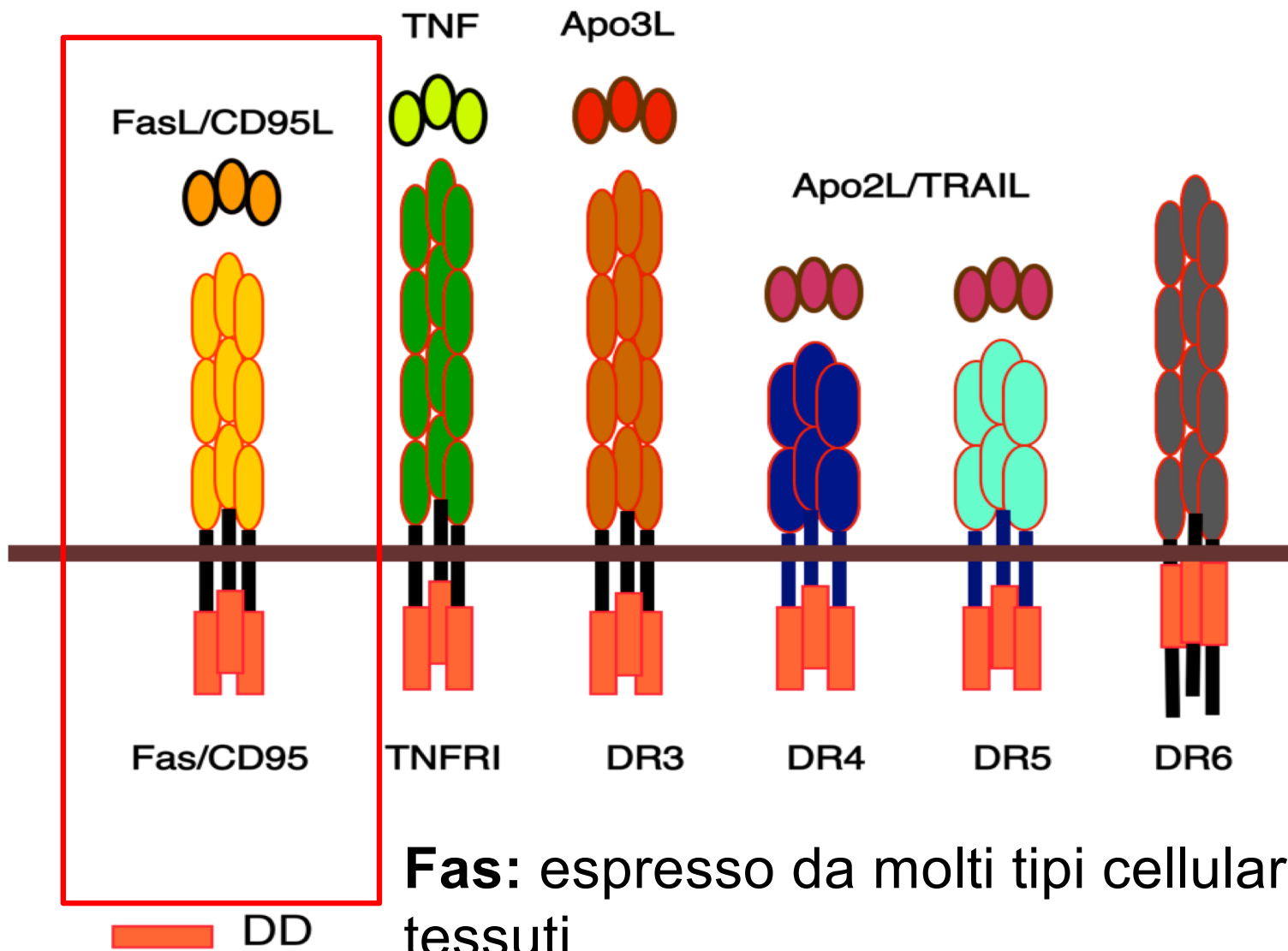

Fas: espresso da molti tipi cellulari in diversi tessuti

FasL: espresso da cellule Th1, CTL e NK

Fas come esempio di Recettore di morte “Death receptor”

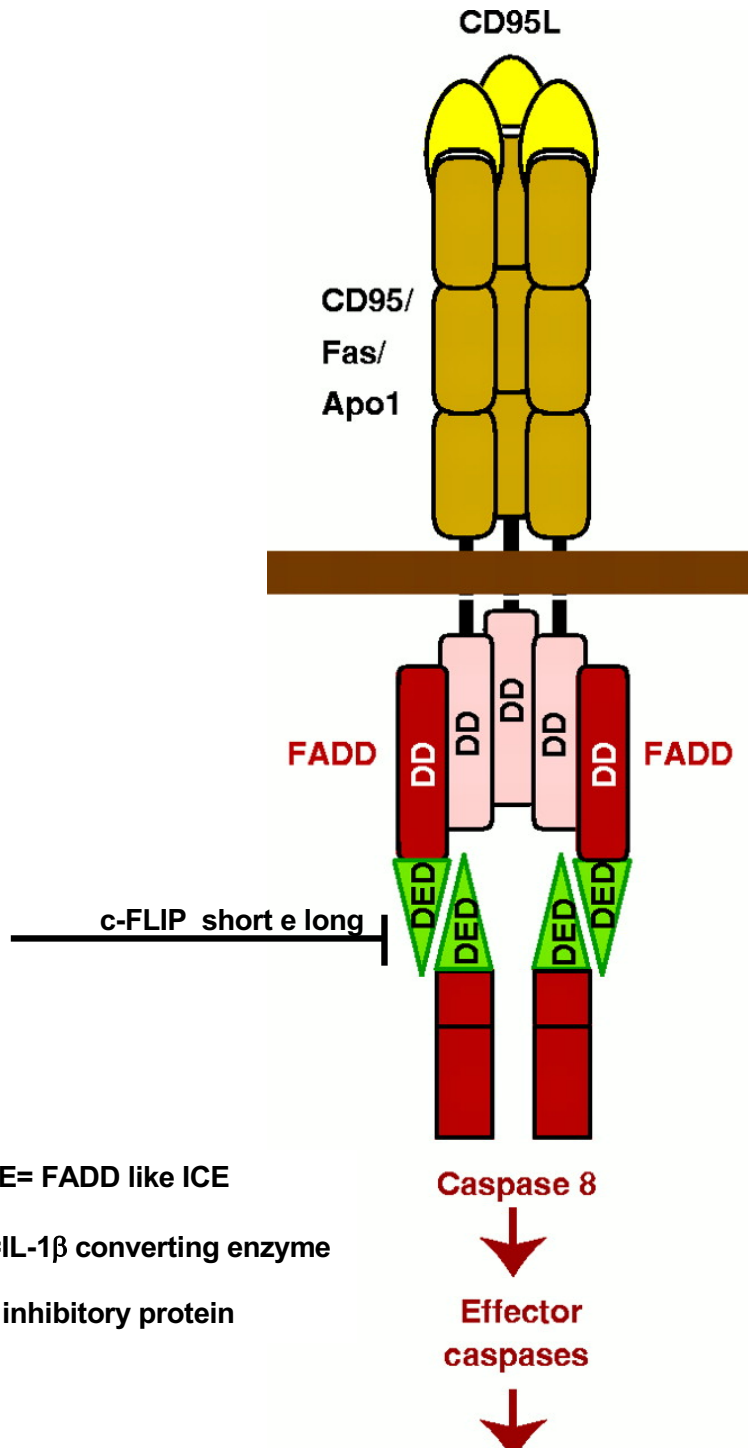

- Segnali esterni inducono i recettori di morte (DR)
- per esempio: CD95 (Fas/Apo-1)
- Ogni trimero CD95L si lega a 3 CD95 portando al clustering DD.
- FADD (dominio di morte associato a Fas) si lega tramite il proprio DD
- L'oligomerizzazione della caspasi 8 guida l'attivazione attraverso l'autoscissione
- La caspasi 8 attiva quindi le caspasi effettrici a valle
- Inizio dell'apoptosi

Caspasi 8 o FLICE= FADD like ICE

ICE o caspasi 1 =IL-1 β converting enzyme

FLIP= FLICE-like inhibitory protein

Apoptosis Signalling network

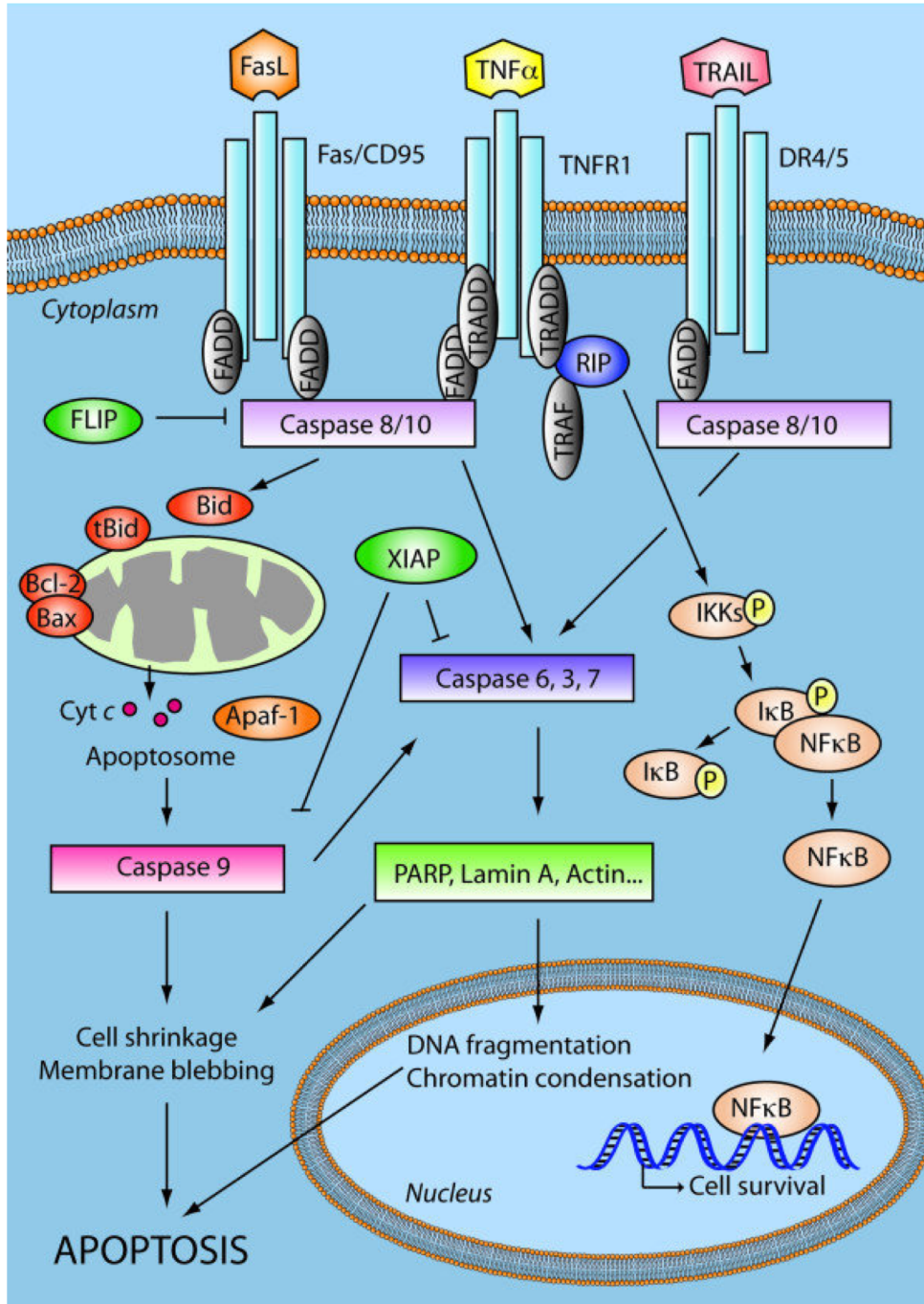

The **extrinsic apoptosis pathway** is activated upon ligand binding to death receptors (TNFR1, Fas/CD95, DR4/5). This results in activation of a caspase cascade and eventually cleavage of both cytoplasmic and nuclear substrates. TNFR1 may promote survival signalling through activation of NF κ B. The intrinsic pathway involves release of apoptotic proteins from the mitochondria, formation of the apoptosome and subsequently caspase activation. Members of the BCL-2 protein family are involved in regulation of the intrinsic apoptotic pathway. The extrinsic and the intrinsic pathways converge in a caspase cascade that results in cellular shrinkage, DNA fragmentation and eventually apoptosis. Tumour necrosis factor receptor (TNFR), Tumour necrosis related apoptosis-inducing ligand (TRAIL), TNFR type 1-associated death domain protein (TRADD), Death receptor (DR), Fas-associated protein with death domain (FADD), TNFR associated factor (TRAF), Receptor interacting protein (RIP), FLICE-like inhibitory protein (FLIP), X-linked inhibitor of apoptosis protein (XIAP), Nuclear factor kappa-light-chain-enhancer of activated B cells (NF κ B), Inhibitor of κ B (I κ B), I κ B kinases (IKKs), cytochrome c (Cyt c), Apoptotic protease activating factor 1 (Apaf-1).

Malattie autoimmuni umane a tratto mendeliano: le ALPS

(sindrome linfoproliferativa autoimmune)

Causate da mutazioni di:

Fas

FasL

Caspasi 8 o 10

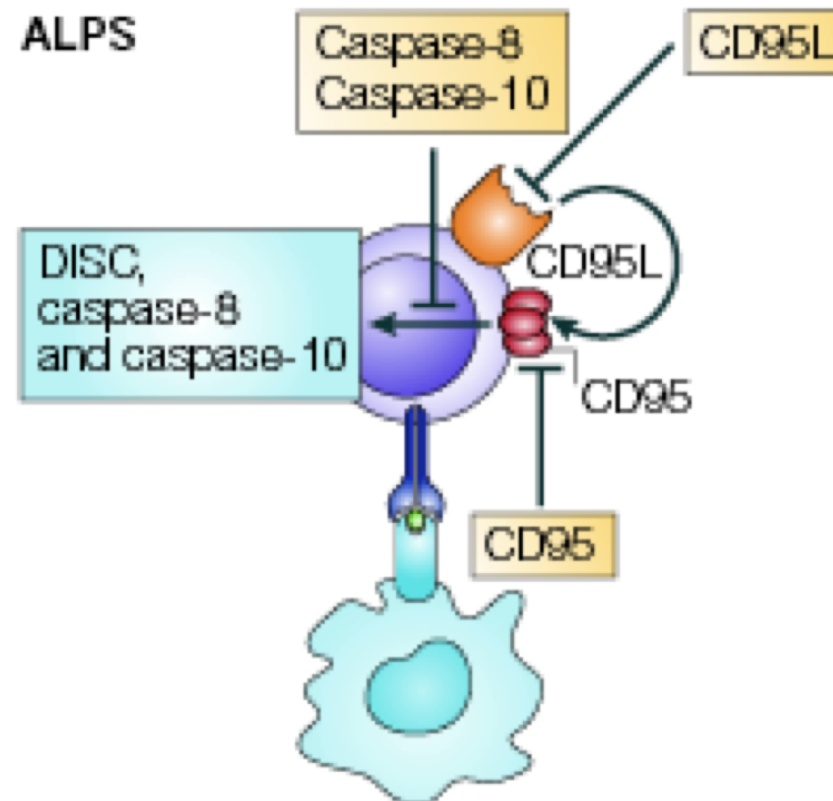

ALPS1a	Autoimmunity, hypergammaglobulinaemia, lymphoproliferation, and excessive numbers of CD3 ⁺ CD4 ⁺ CD8 ⁻ αβ-TCR ⁺ T cells	10q24.1	CD95 (heterozygous, germ line) CD95 (heterozygous, somatic)
ALPS1b	Autoimmunity, hypergammaglobulinaemia, lymphoproliferation, and excessive numbers of CD3 ⁺ CD4 ⁺ CD8 ⁻ αβ-TCR ⁺ T cells	1q23	CD95L
ALPS2	Autoimmunity, hypergammaglobulinaemia, lymphoproliferation, and excessive numbers of CD3 ⁺ CD4 ⁺ CD8 ⁻ αβ-TCR ⁺ T cells	2q33-2q34	CASP8 CASP10

Caspasi: esecutori centrali del programma di morte

sono proteasi cisteiniche altamente conservate
(distinte in **iniziatrici**/attivatrici e **effettrici**/esecutrici)
13 membri identificati nell'uomo

Riconoscono sequenze del tipo:

	P4	P3	P2	P1	TAGLIO	caspasi
Gruppo I :	idrofobico					1; 4; 5;
Gruppo II :	Asp	Glu	X	Asp		2; 3; 7
Gruppo III :	alifatico					6; 8; 9; 10

sono raggruppate per specificità del substrato, similitudine di sequenza e omologia strutturale

Sono sintetizzate come zimogeni (precursori inattivi) composti da tre domini:

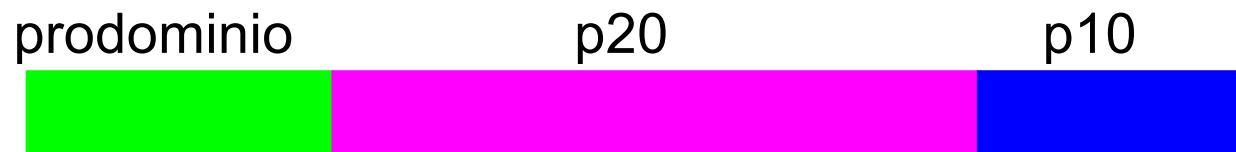

La forma matura è un eterotetramero p20/p10 + p20/p10

Caspasi apoptotiche

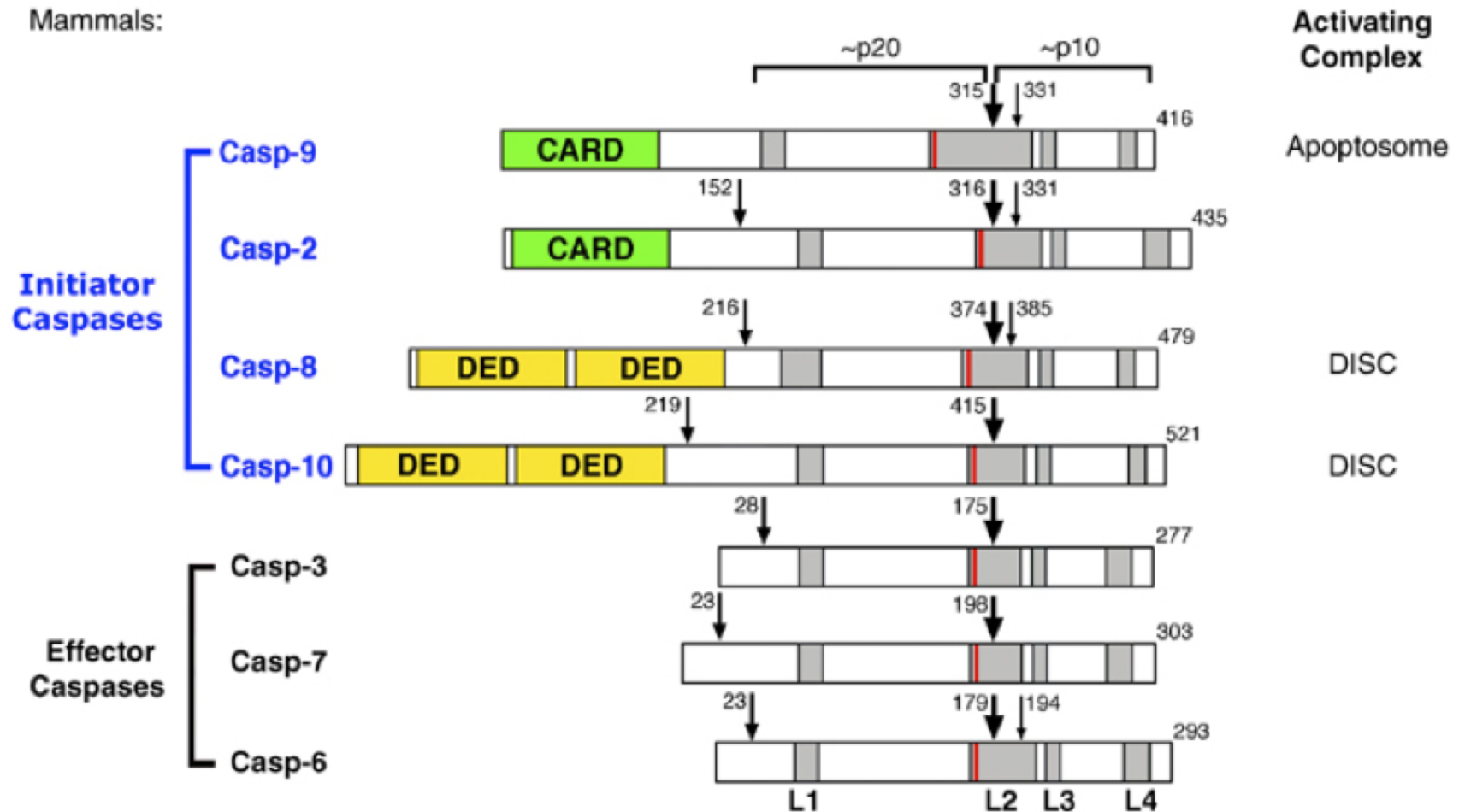

Caspasi iniziatrici: Casp-9, Casp-2, Casp-8 e Casp-10

Caspasi effettrici: Casp-3, 6 e 7

Domini di reclutamento all'N-terminale delle caspasi iniziatrici: **CARD** e **DED**

Attivazione delle caspasi

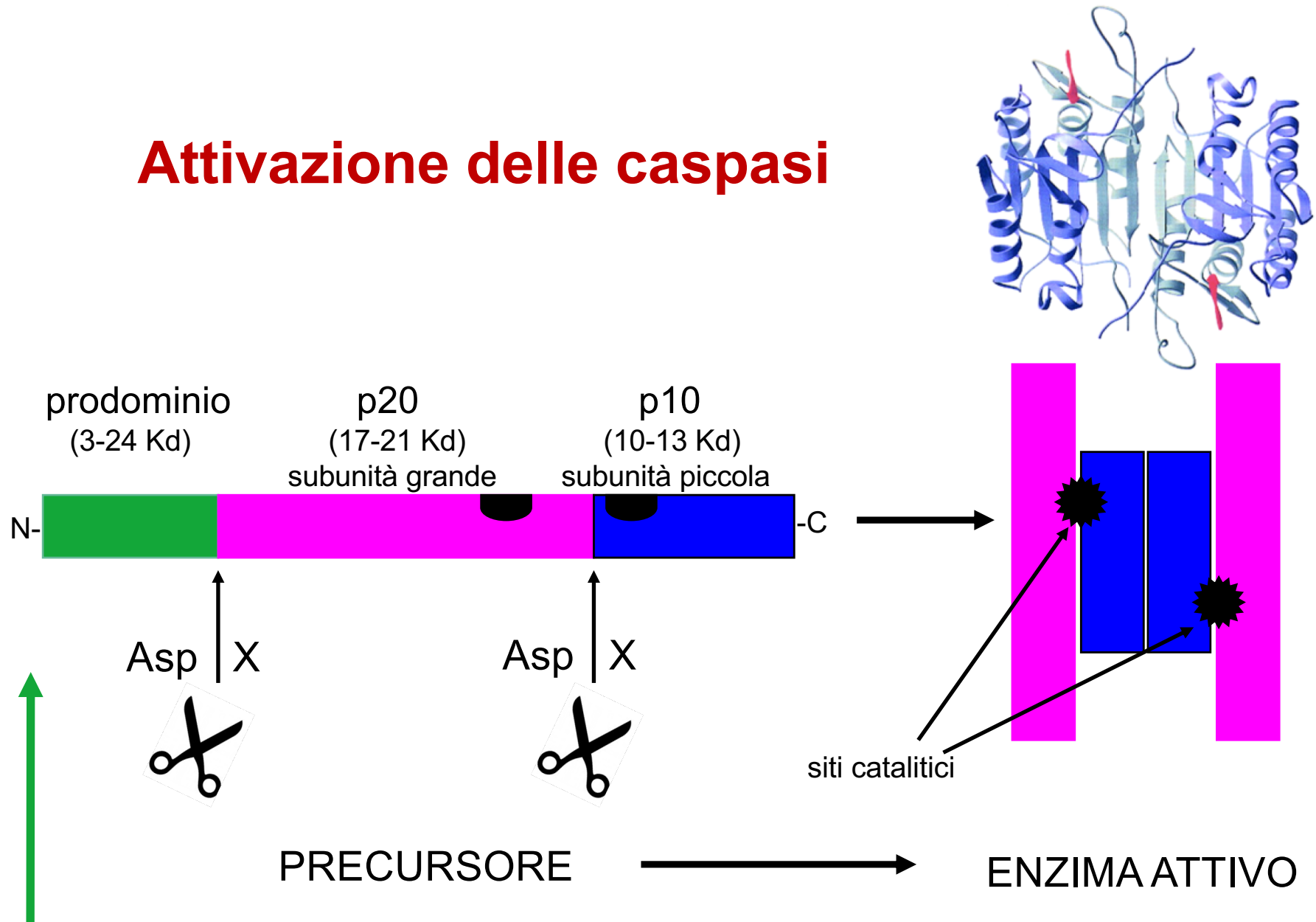

Modulo di reclutamento per l'interazione proteina-proteina

DED=death effector domain (caspasi 8 e 10)

CARD=caspase activation and recruitment domain (caspasi 2 e 9)

Meccanismi di attivazione delle caspasi

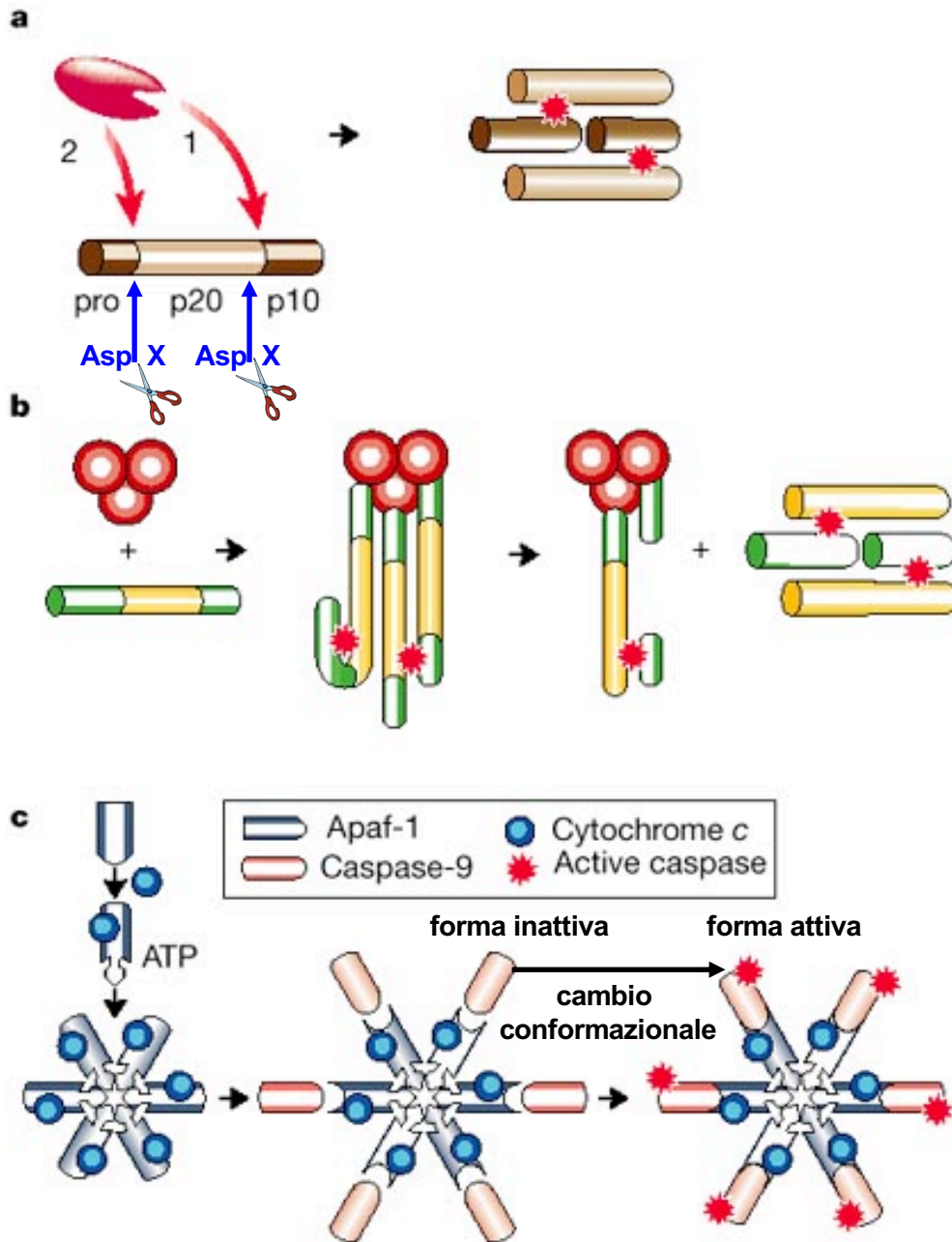

a) **Proteolisi da parte di caspasi o granzimi B (anche autocatalitica):** meccanismo di attivazione delle caspasi effettrici 3, 6, 7

b) **Attivazione autocatalitica:** meccanismo delle caspasi 8 e 2

c) **Formazione di un oloenzima:** meccanismo di attivazione della caspasi 9

apoptosoma

Processo di formazione dell'apoptosoma ed attivazione della caspasi 9

- Il citocromo c lega il monomero APAF1, portando alla sua oligomerizzazione in una struttura eptamerica simile a una ruota chiamata apoptosoma
- L'apoptosoma recluta e attiva la procaspasi 9
- La caspasi 9 attiva la caspasi 3 e 7

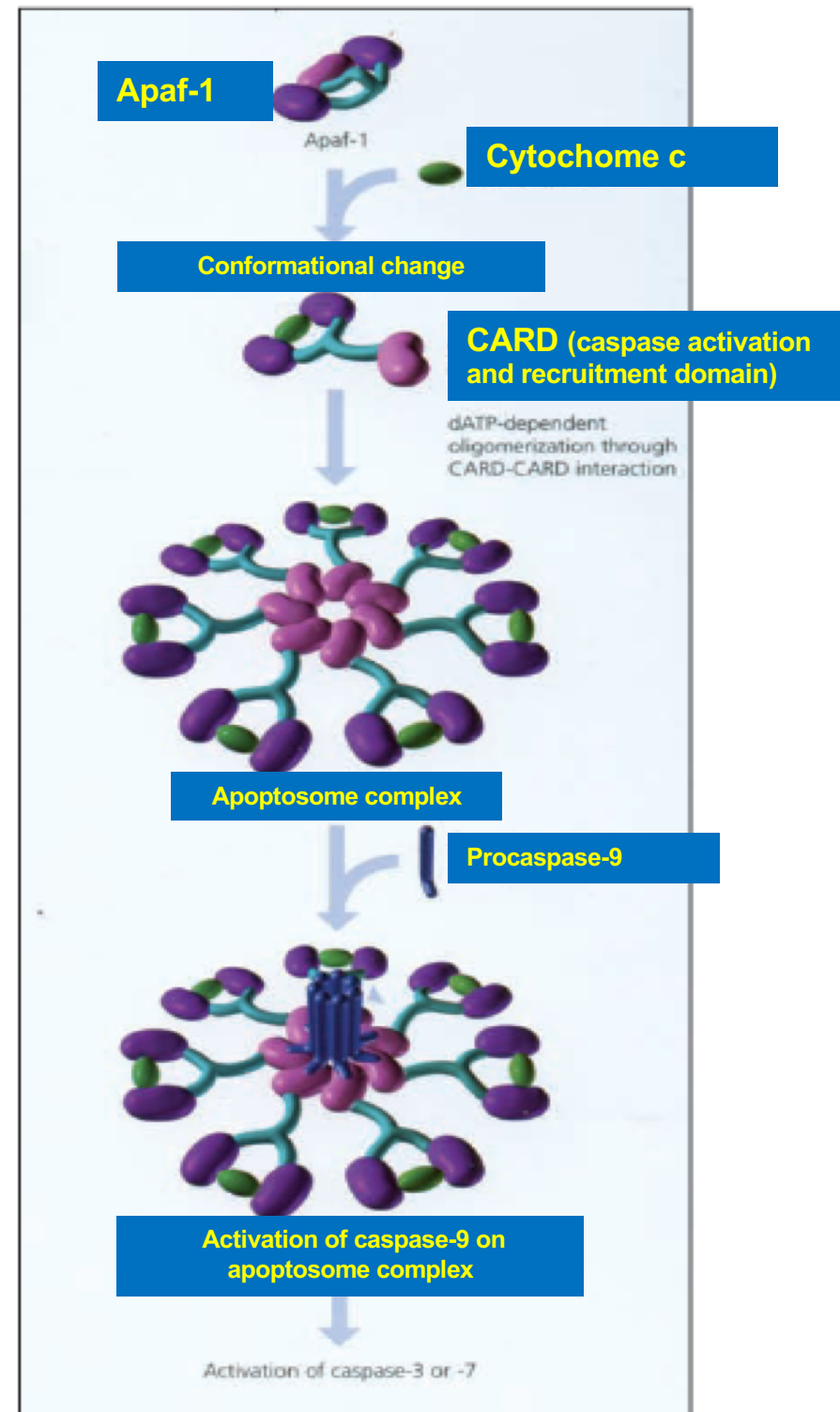
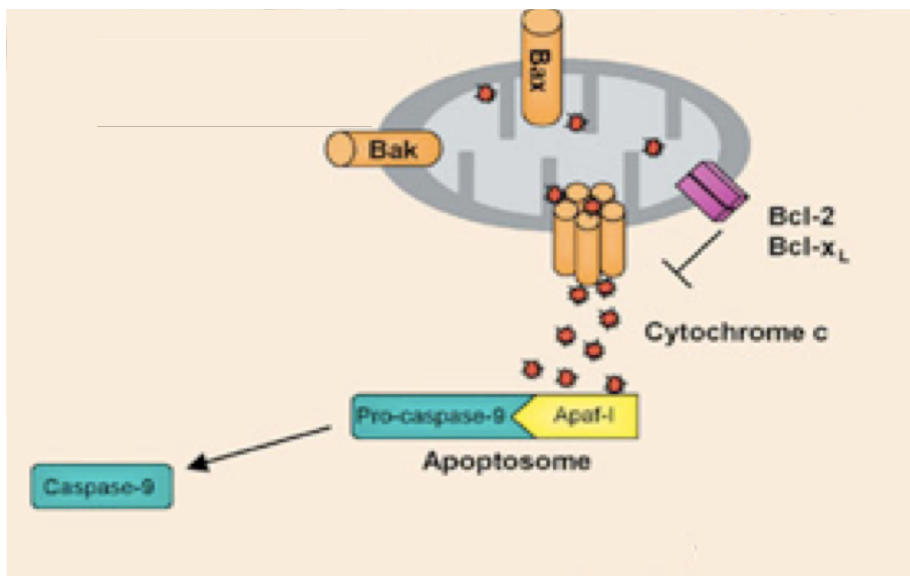

Esiti dell'azione delle caspasi: attivazione o inattivazione

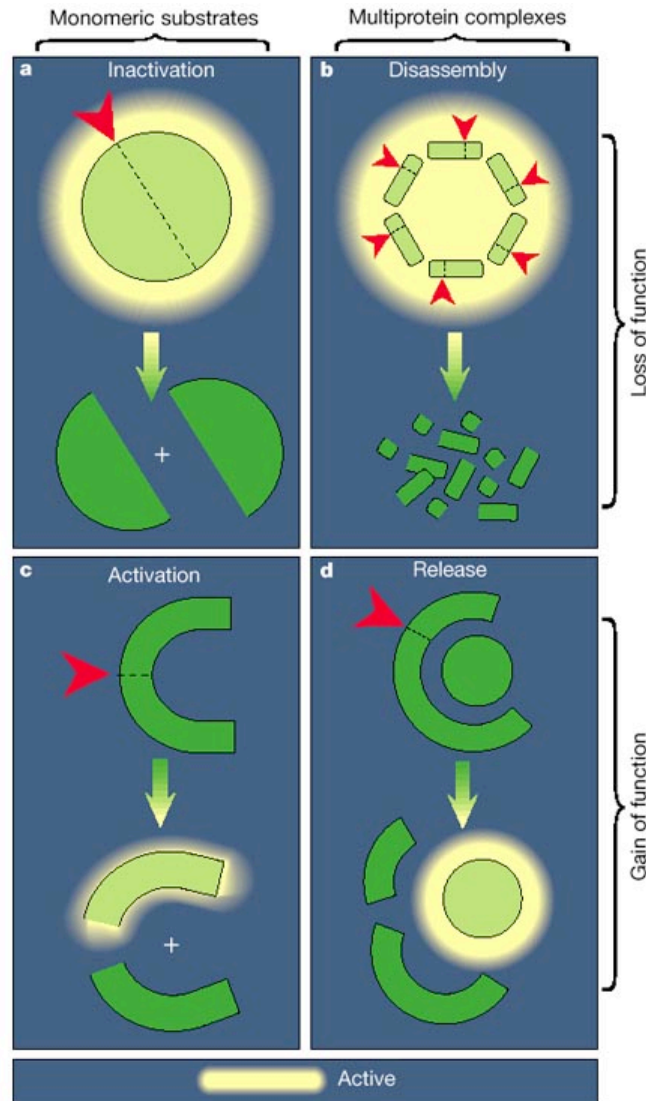

Proteolytic cleavage by caspases can lead to diverse results, depending on the nature of the substrate and the exact position of the cleavage site in the primary sequence. The simplest, and probably most frequent outcome is loss of biological activity (panels a, b in the figure below). Caspase substrates range from single polypeptide chain enzymes (for example, **poly ADP-ribose polymerase**) to complex macromolecular structures (for example, the **nuclear lamin network**). Limited proteolysis by caspases can also result in a gain of biological activity (c, d). In some cases (for example, **Bcl-2 or Bcl-xL**), the cleaved products antagonize the full-length protein (dominant-negative forms). **In other cases, removal of inhibitory domains or subunits results in increased biological activity (for example, Bid and CAD/ICAD).**

Caspases 2, 3, 6, 7, 8, 9, 10 are centrally involved in apoptosis.

Caspases 1, 4, 5, 13, 14 have as primary role the cytokine processing during inflammation and proinflammatory cell death.

Taglio del DNA nelle regioni inter-nucleosomali

Il DNA viene visualizzato come un ladder di 180-200 bp a causa della scissione del DNA nelle regioni tra i nucleosomi

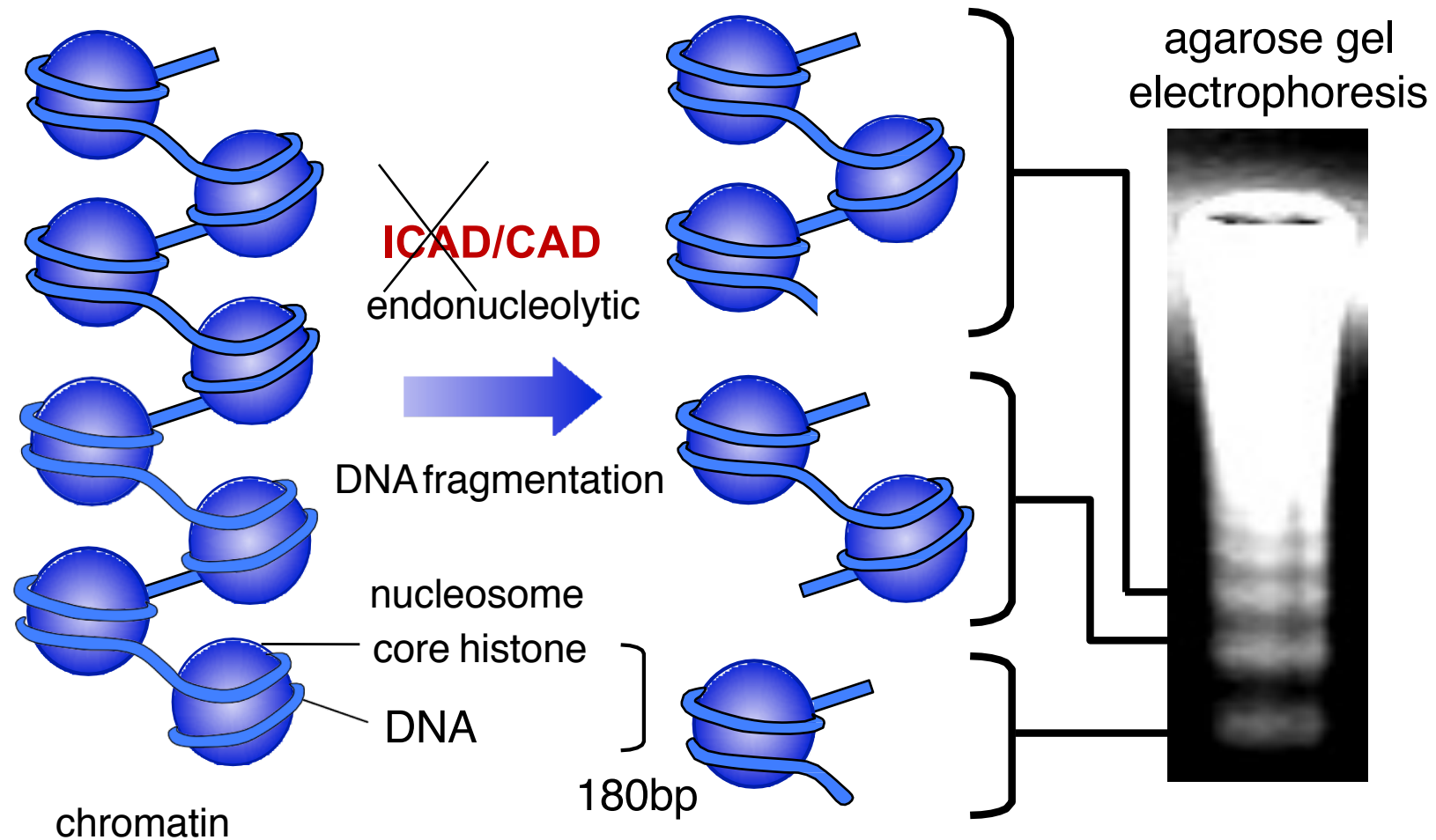

Il taglio del DNA è effettuato da CAD (Caspase-activated DNase) dopo rimozione (taglio) del suo inibitore ICAD da parte della caspase 3

I due pathway dell'apoptosi

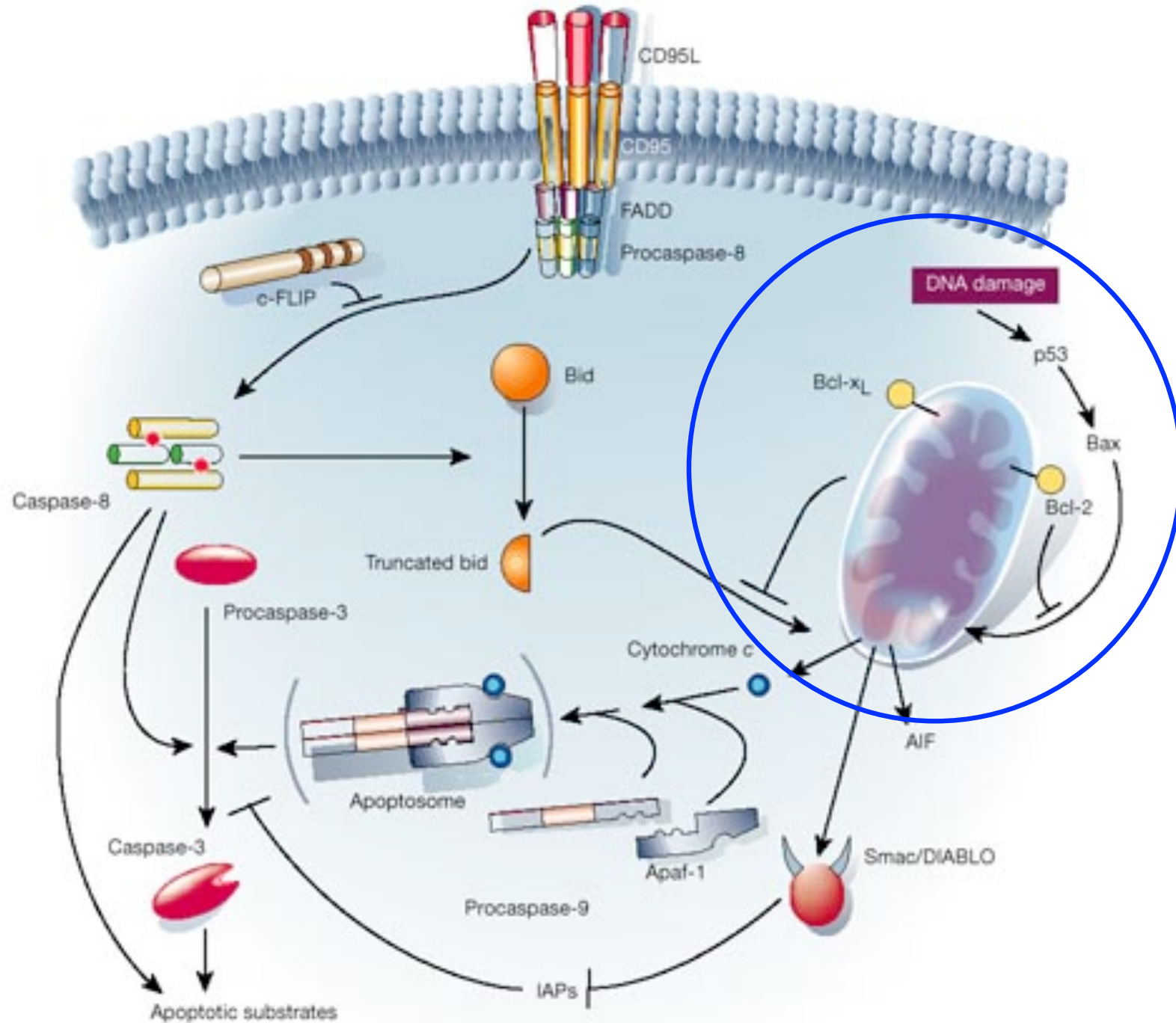

Via mitocondriale della cascata apoptotica

viene solitamente attivata in risposta a stress cellulare (danno al DNA, stress ossidativo e ipossia)



I mitocondri contengono fattori pro-apoptotici come il citocromo c (cyt c) e AIF (fattore che induce l'apoptosi).

Questi sono innocui quando sono sequestrati in modo sicuro all'interno dei mitocondri ma attivano la cascata delle caspasi una volta rilasciati nel citosol.

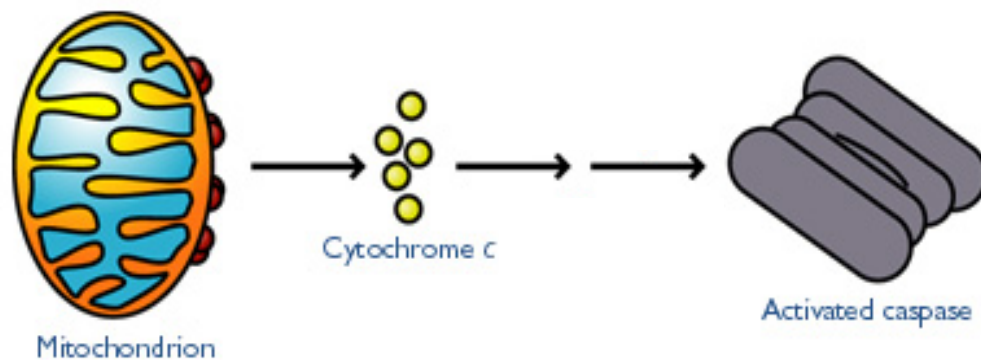

Nel citosol **il citocromo C** si lega ad Apaf-1 (Apoptosis Activation Factor-1) permettendo l'attivazione della procaspasi 9 → **caspase 9** attiva

Membri della famiglia Bcl-2

Pro-survival

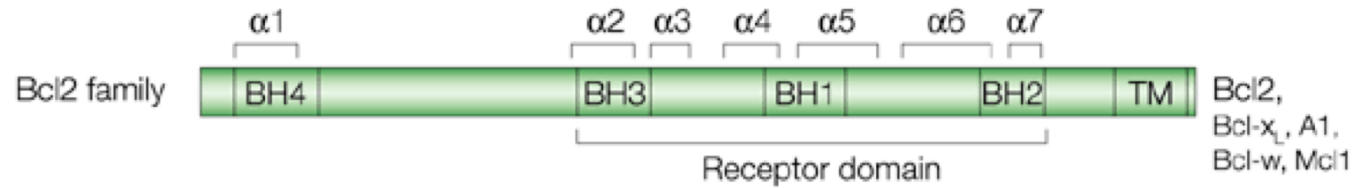

Pro-apoptosis

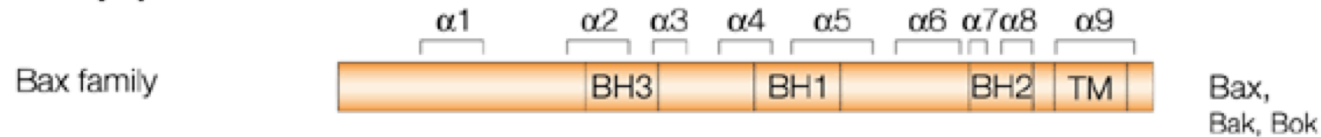

BH3-only family

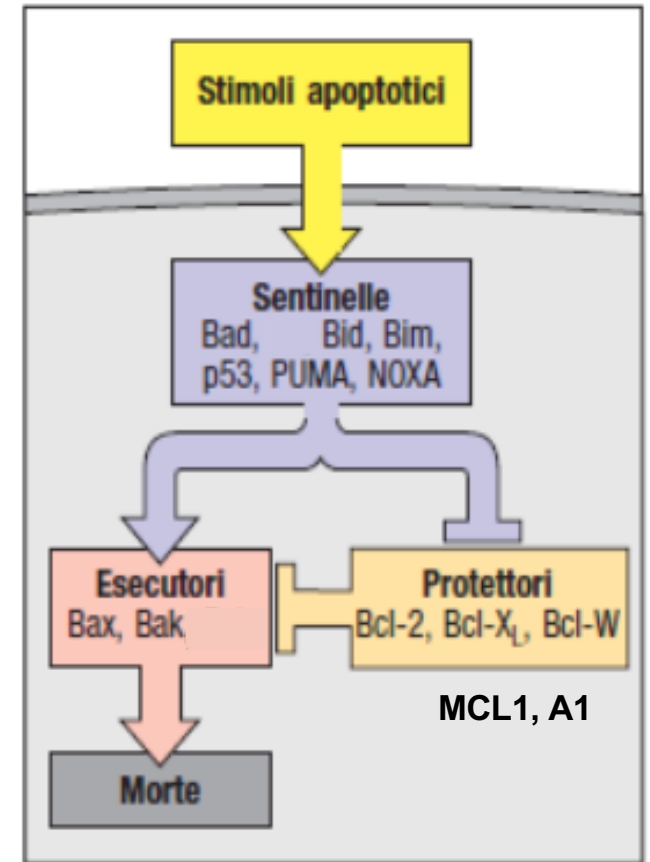
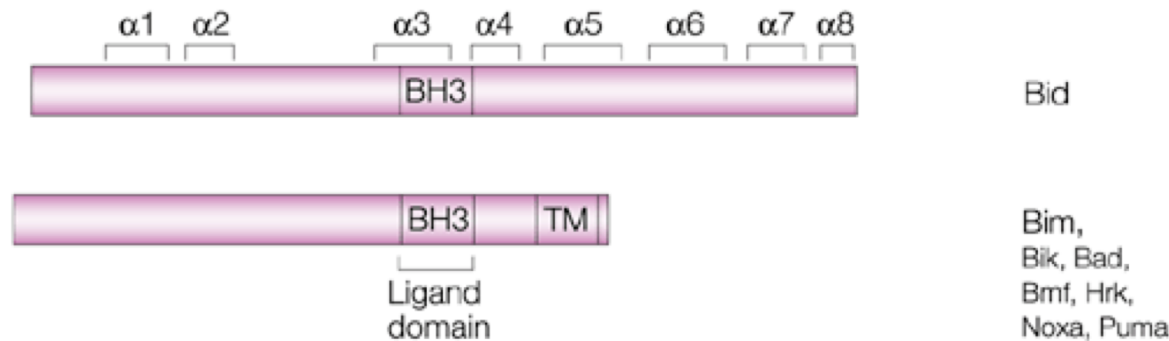

Bcl-2 e **Bak** sono sempre legati alla membrana mitocondriale; gli altri membri passano dal citosol (forme inattive) alla membrana mitocondriale (forme attive). Le proteine “BH3 only” si attivano per proteolisi, defosforilazione ed altri meccanismi.

Interazione tra membri della famiglia BCL2

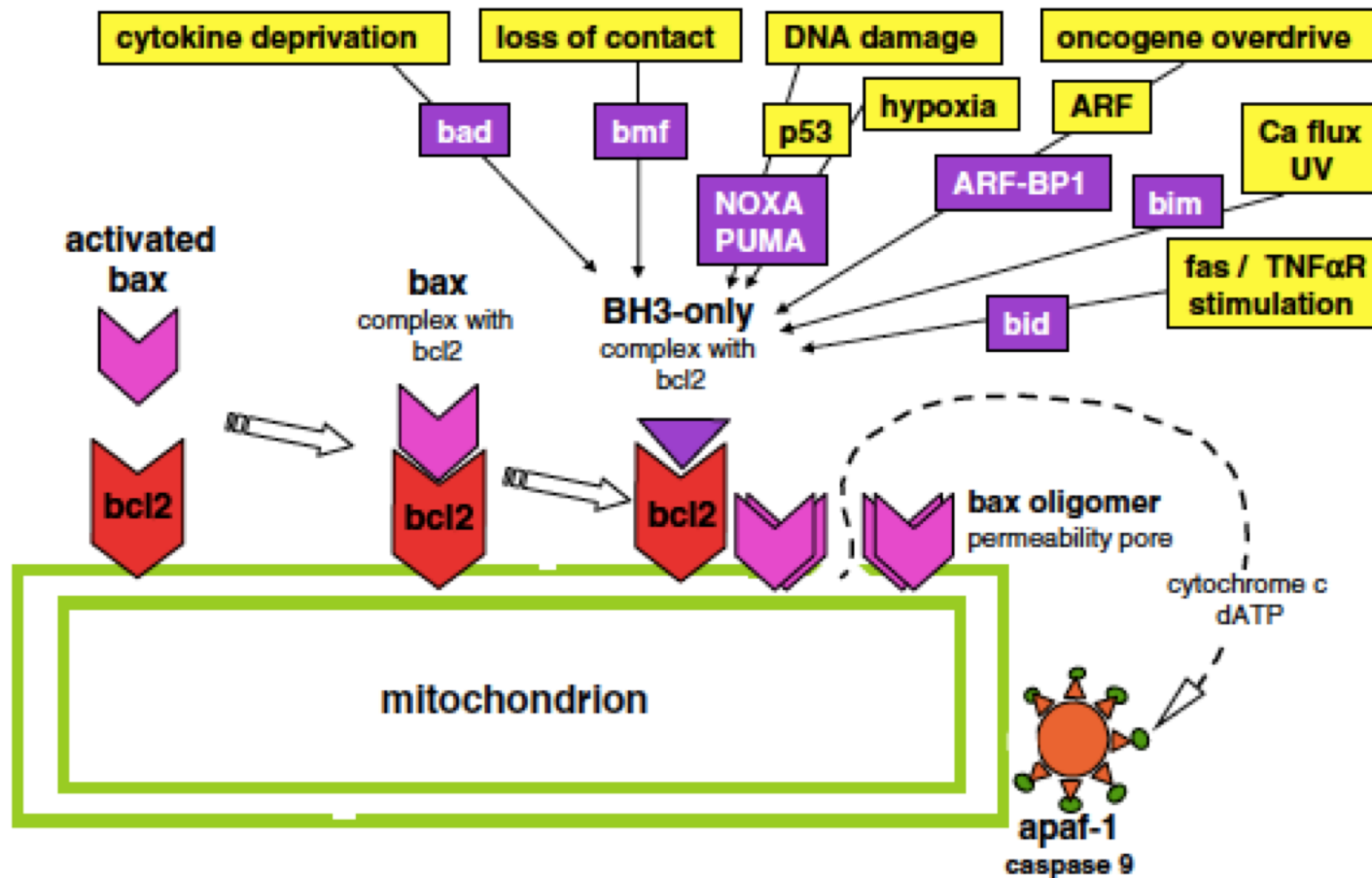

Diagrammatic representation of the interaction of BH3-only members of the BCL2 family with the bax/bak-BCL2/BCL_{xL} complexes on mitochondrial membranes, relative to a variety of injury stimuli

L'integrità mitocondriale è controllata dai membri della famiglia Bcl-2

b Mammals: mitochondrial integrity model

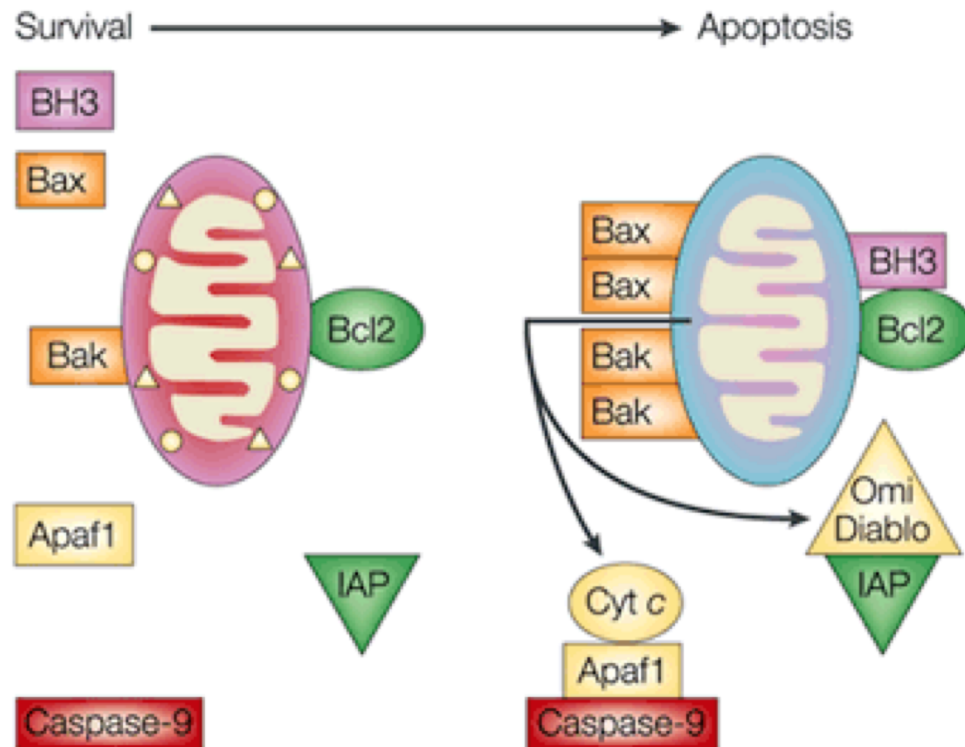

Membri pro-apoptotici:

Bax e **Bak** (effettori/esecutori)

Bid, Bim e Puma (attivatori diretti)

Bad, BIK, BMF, Noxa
("sensitizer"/derepressori)

Bcl2 and its anti-apoptotic homologues guard mitochondrial membrane integrity until neutralized by a BH3-only protein. Bax and Bak then form homo-oligomers within the mitochondrial membrane, resulting in the release of cytochrome c, which activates Apaf1, allowing it to bind to and activate caspase-9. Other pro-apoptotic molecules that exit the mitochondria include Omi and Diablo, which antagonize inhibitor of apoptosis proteins (IAPs). Protein complexes are shown as juxtaposed boxes or triangles. Apaf1, apoptotic protease-activating factor 1; cyt c, cytochrome c.

BIM, BID, NOXA, PUMA

Oligomerizzazione di BAX o BAK

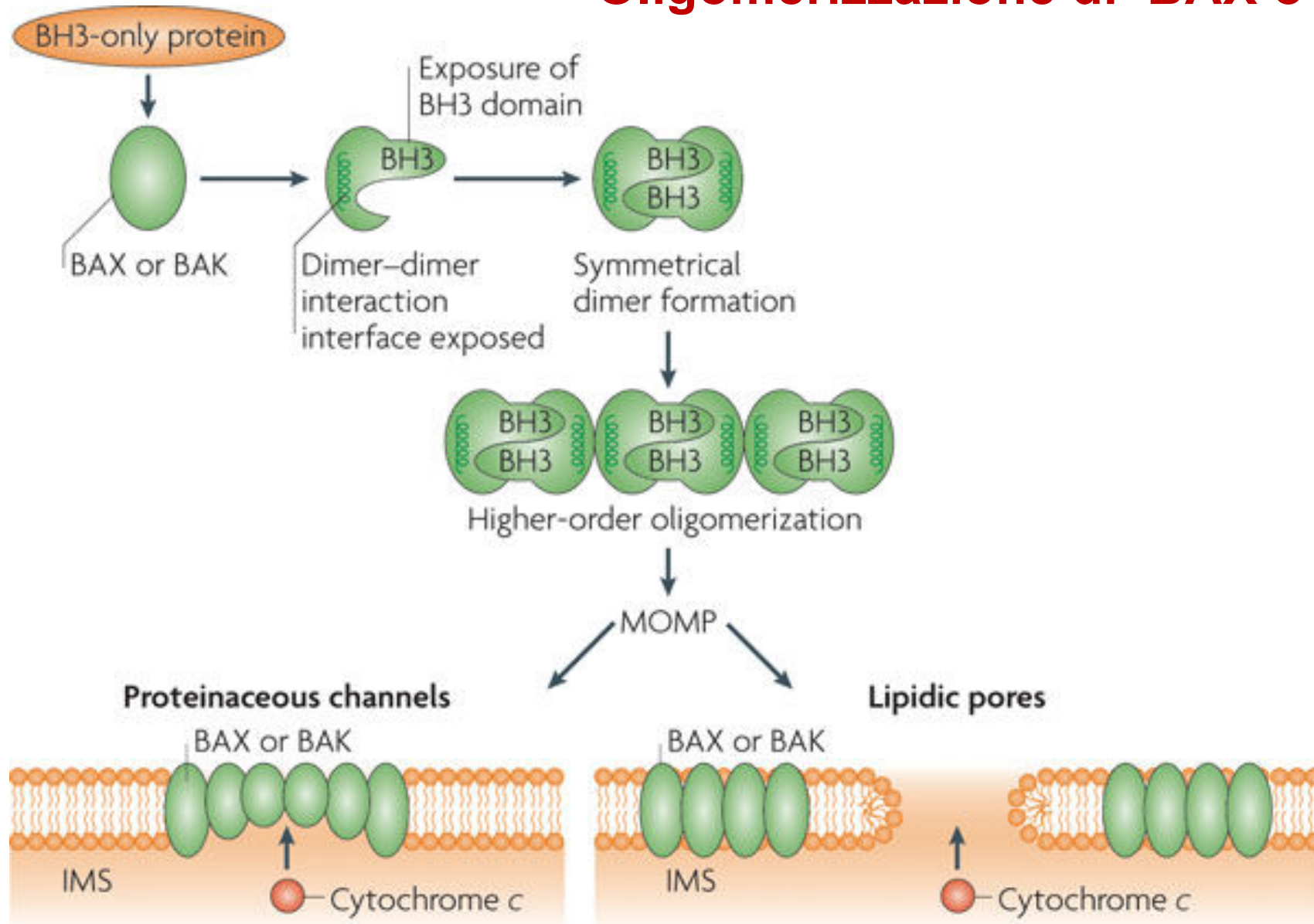

Ruolo dei membri della famiglia Bcl-2 nella permeabilizzazione della membrana del mitocondrio: possibili meccanismi

Canali mitocondriali coinvolti nella transizione della permeabilità della membrana del mitocondrio (MPT):

MAC (mitochondrial apoptosis-induced channel)
sulla membrana esterna

Bax e Bak oligomerizzano formando il **MAC** un poro/canale attraverso cui fuoriesce il Citocromo c e gli altri fattori proapoptotici

La formazione del **MAC** è inibita da Bcl-2

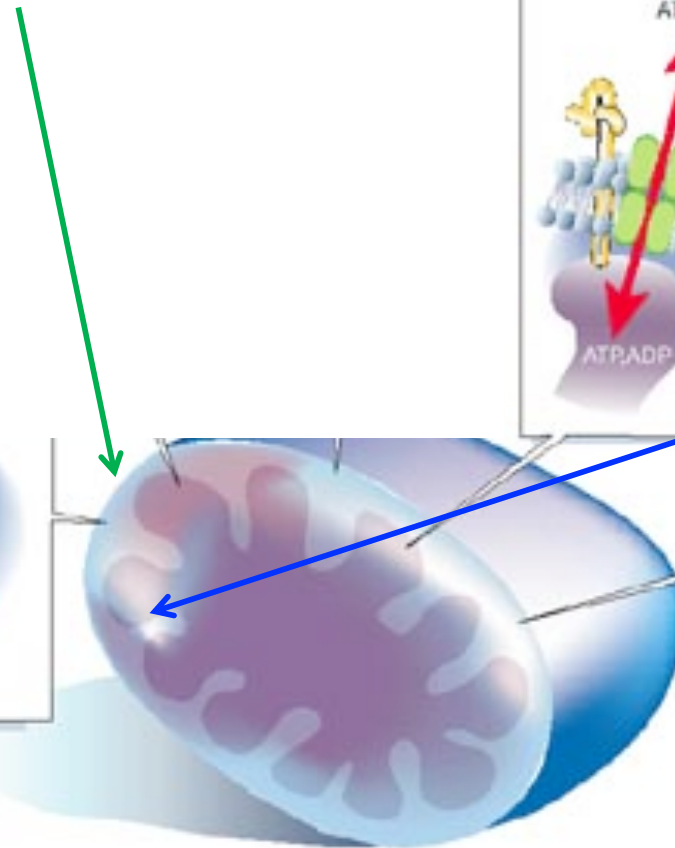
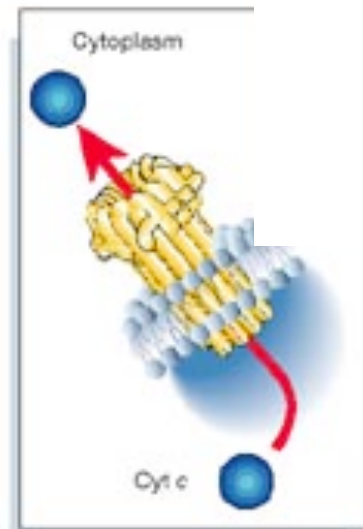
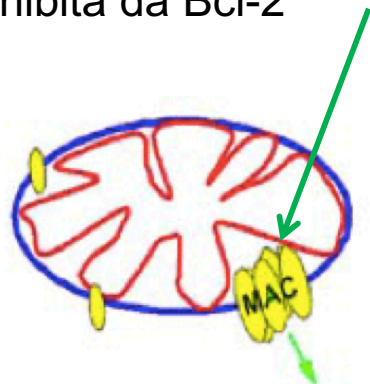

Bcl2 e gli altri membri antiapoptotici interagiscono e bloccano alcune proteine del **PTP** quali ad es. VDAC (voltage dependent anion channel)
Bax e Bak si associano a componenti del **PTP** dopo una sua persistente apertura

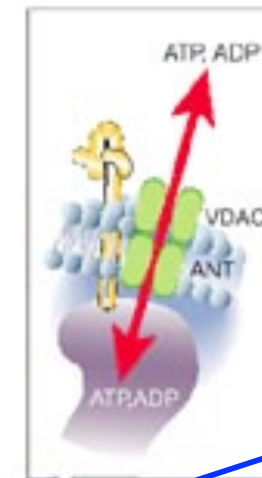

PTP (permeability transition pore)
sulla membrana interna

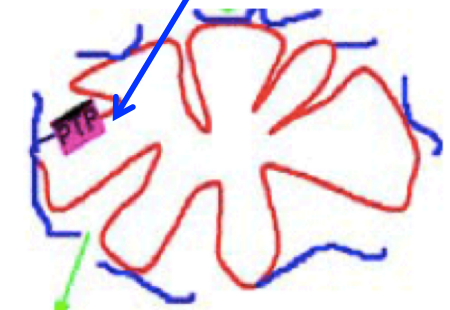

Rilascio di citocromo C

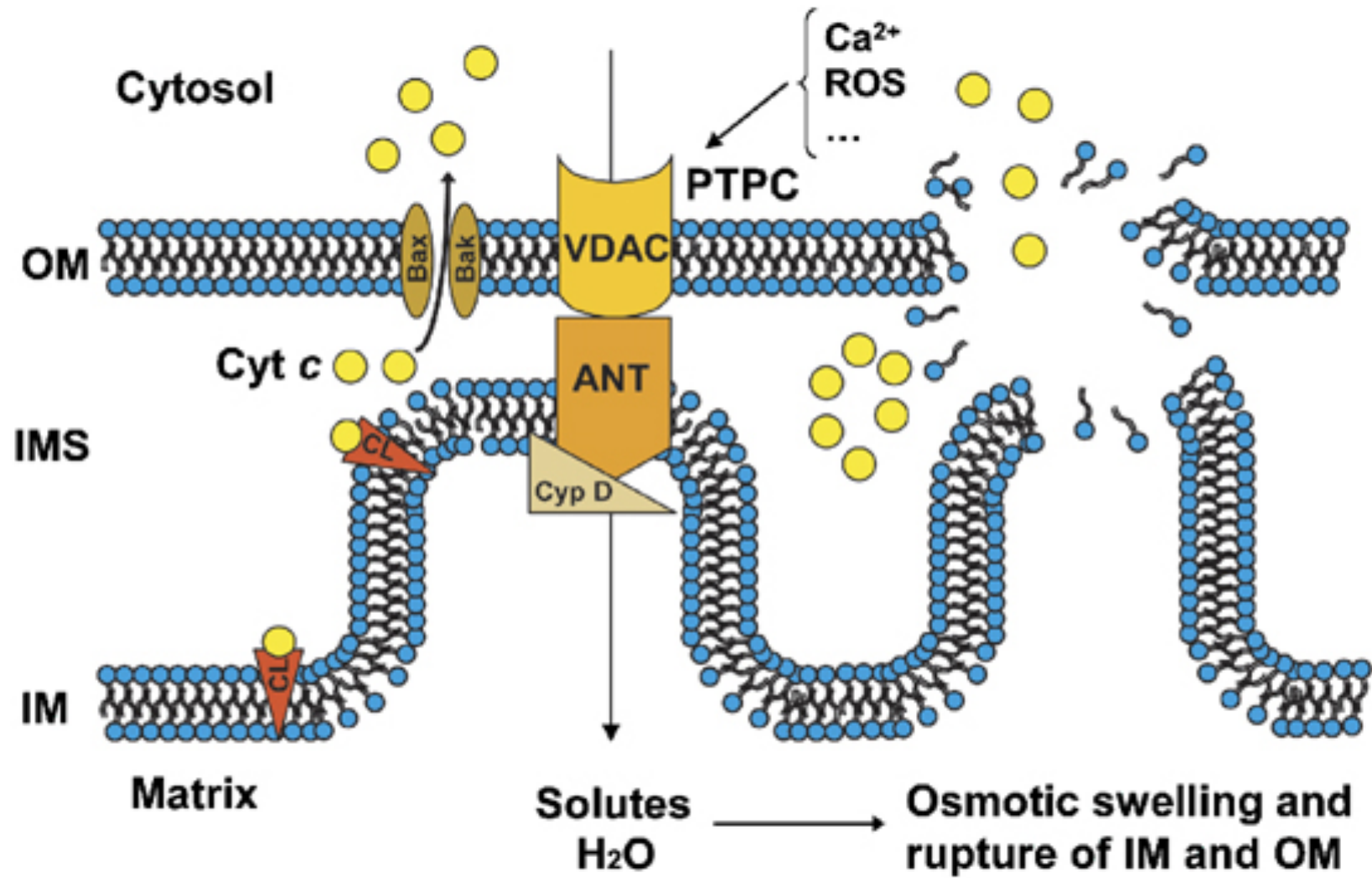

Necroptosis and Pyroptosis: forms of necrosis

Necrosis

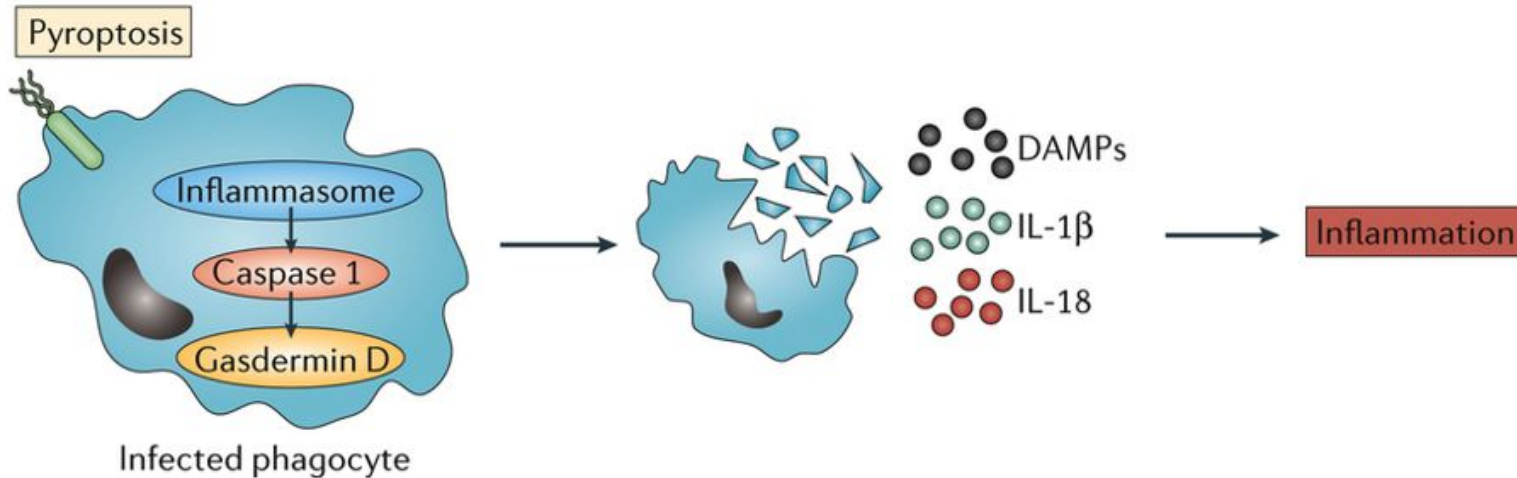
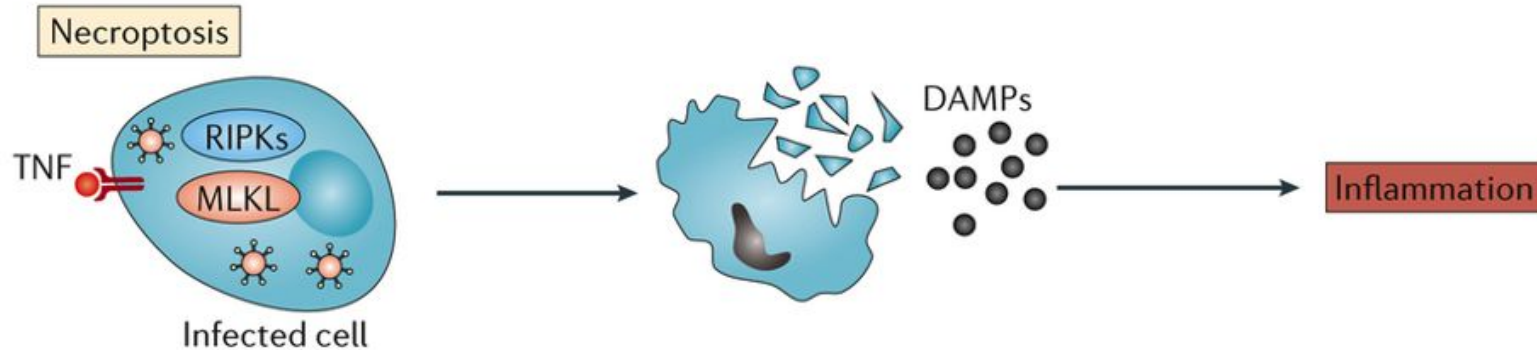

Nature Reviews | Immunology

Bacteria-infected cells, particularly phagocytes, often undergo necrosis to prevent bacteria from proliferating further inside the cell. Unlike apoptosis, necrosis is an inflammatory form of cell death and can lead to further tissue inflammation. DAMPs, damage-associated molecular patterns.