

Strategie molecolari per studiare la funzione di un gene

Aumento espressione del gene endogeno

Riduzione/silenziamento del gene endogeno

Knock Out del gene.....

Genetica Forward

Genetica Reverse

GENETICA FORWARD E REVERSE

Obiettivo: assegnare una funzione ad ogni gene

Forward Genetics:

il metodo classico per determinare la funzione di un gene si basa sull'isolamento e analisi di mutazioni in quel gene: mutagenesi sistematica delle sequenze geniche per produrre collezioni di **mutazioni (prevalentemente recessive) di tipo “loss of function”**. Utilizzando varie tecniche di clonaggio si risale alla sequenza genica.

Reverse Genetics:

La disponibilità della sequenza del genoma di molte specie ha reso possibile un diverso approccio per la determinazione della funzione di un gene. A partire da una sequenza genica è possibile isolare la linea mutante in cui l'elemento inserzionale è all'interno della sequenza d'interesse. Dallo studio fenotipico del mutante, si può dedurre la funzione del gene.

Forward Genetics

Mutagenesis,
QTL mapping,
Positional
cloning, etc...

Discover
Gene
underlying
Phenotype

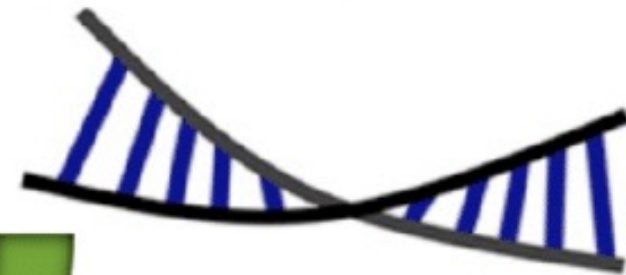

Known Gene

Ectopic expression,
Gene silencing,
Gene targeting,
TILLING, etc...

Reverse Genetics

Phenotype
Resulting
from
Alteration

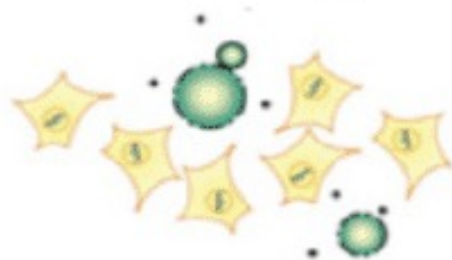

Known Phenotype

Forward Vs Reverse Genetics

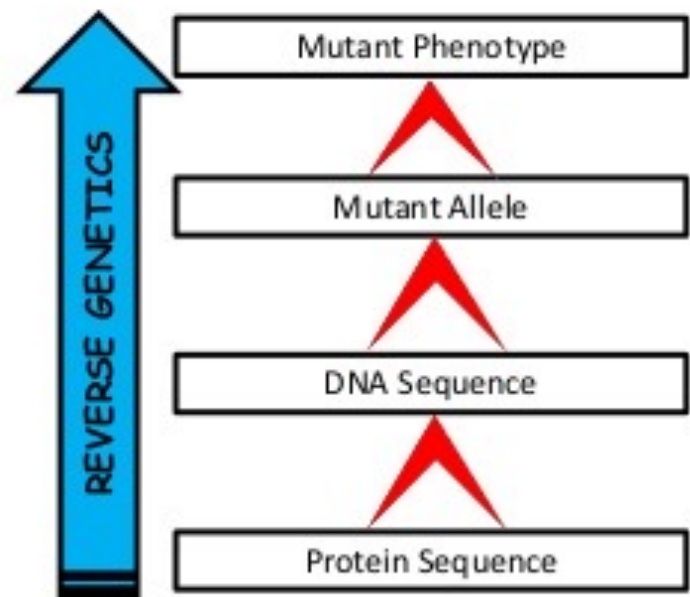
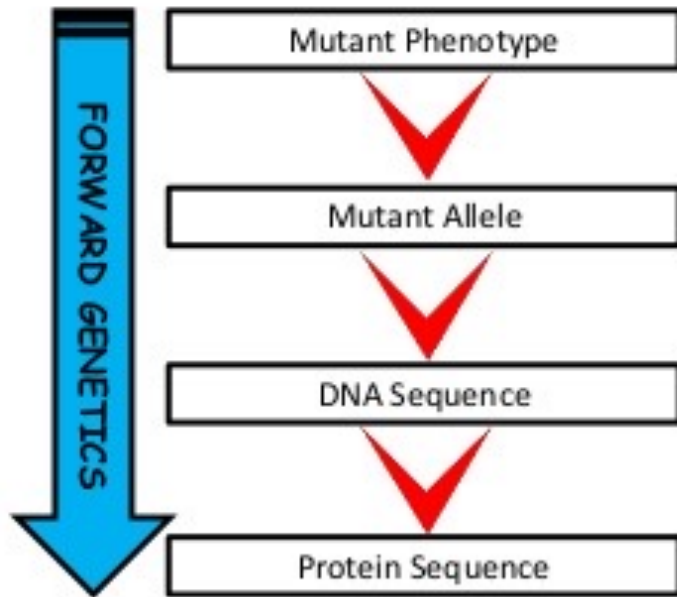

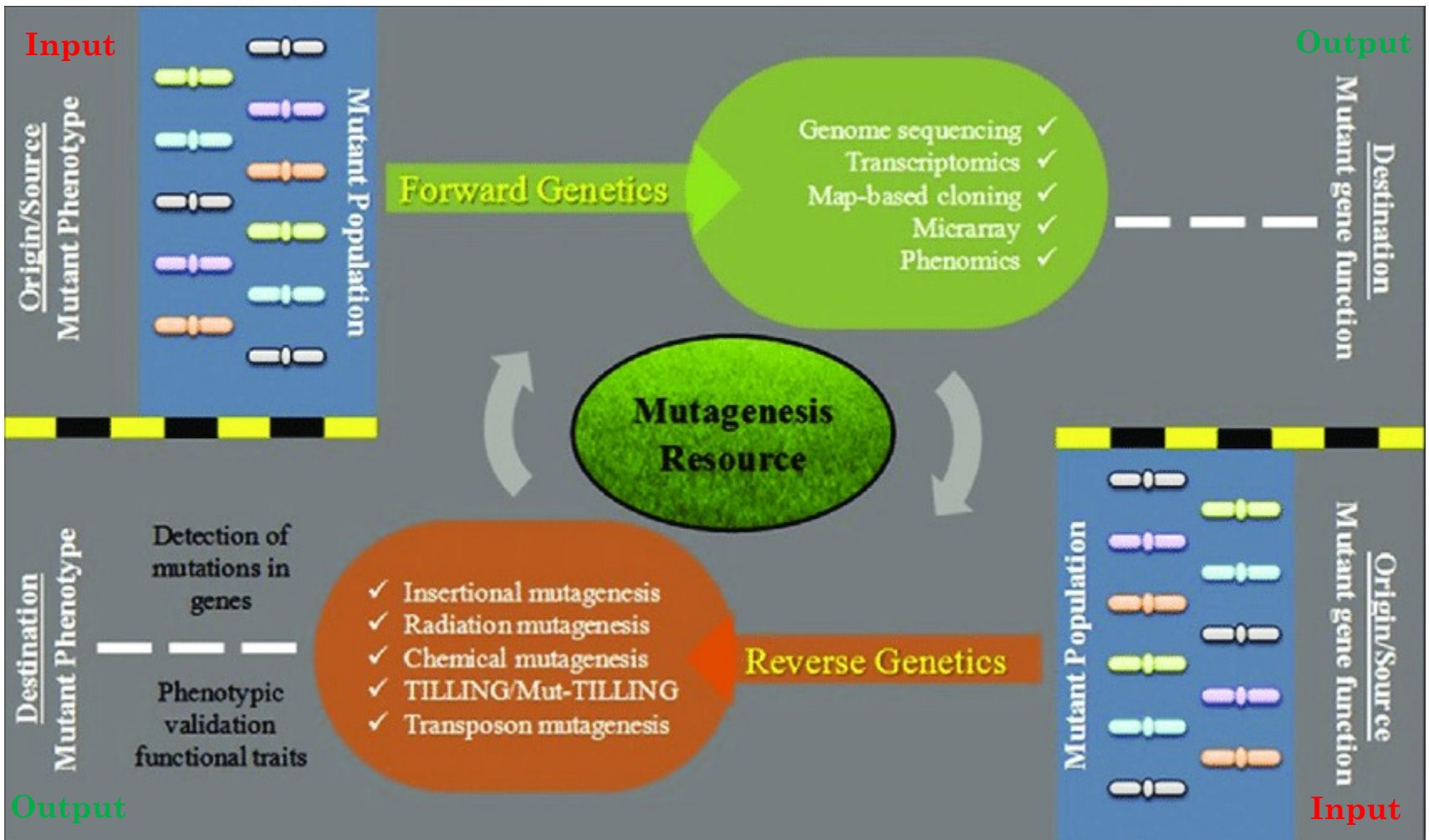

GENES AND PHENOTYPES

Gene: a functional unit of inheritance, usually corresponding to the segment of DNA coding for a single protein.

Genome: an organism's set of genes.

locus: the site of the gene in the genome

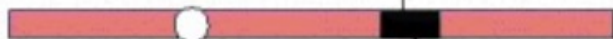

alleles: alternative forms of a gene



GENOTYPE: the specific set of alleles forming the genome of an individual

PHENOTYPE: the visible character of the individual

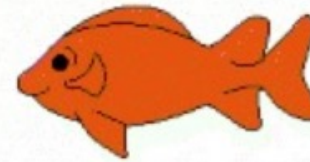

Wild-type: the normal, naturally occurring type



Mutant: differing from the wild-type because of a genetic change (a mutation)

homozygous A/A

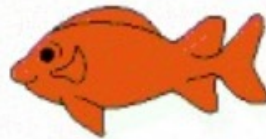
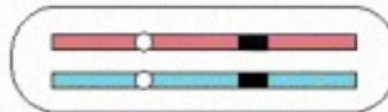

heterozygous a/A

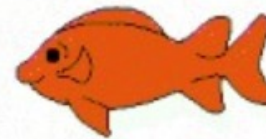

homozygous a/a

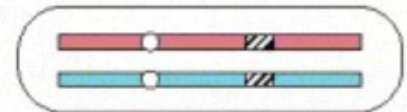

allele A is **dominant** (relative to a); allele a is **recessive** (relative to A)

In the example above, the phenotype of the heterozygote is the same as that of one of the homozygotes; in cases where it is different from both, the two alleles are said to be co-dominant.

Test di Complementazione tra alleli mutanti

TWO GENES OR ONE?

Given two mutations that produce the same phenotype, how can we tell whether they are mutations in the same gene? If the mutations are recessive (as they most often are), the answer can be found by a **complementation test**.

COMPLEMENTATION: MUTATIONS IN TWO DIFFERENT GENES

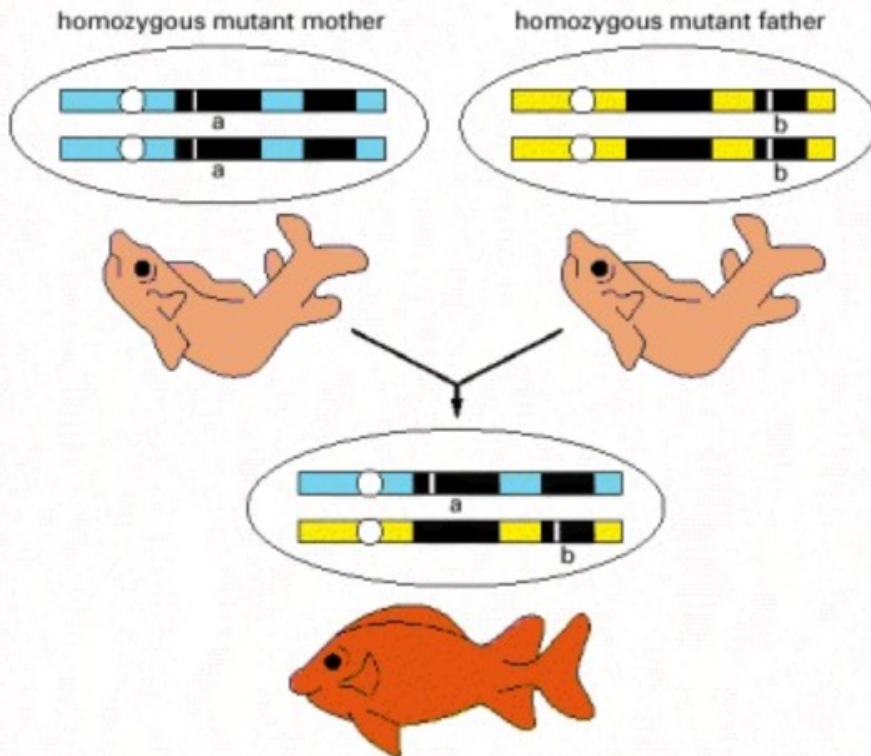

hybrid offspring shows normal phenotype:
one normal copy of each gene is present

In the simplest type of complementation test, an individual who is homozygous for one mutation is mated with an individual who is homozygous for the other. The phenotype of the offspring gives the answer to the question.

NONCOMPLEMENTATION: TWO INDEPENDENT MUTATIONS IN THE SAME GENE

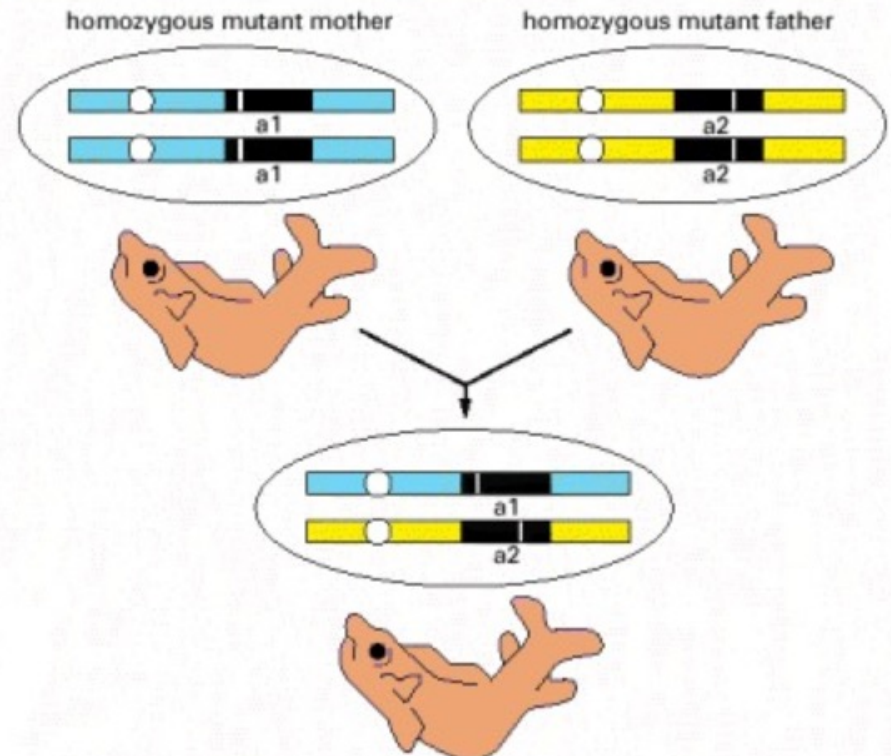

hybrid offspring shows mutant phenotype:
no normal copies of the mutated gene are present

Loss of Function vs Gain of Function mutations

TYPES OF MUTATIONS

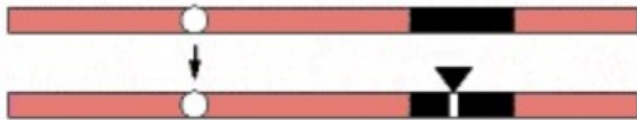

POINT MUTATION: maps to a single site in the genome, corresponding to a single nucleotide pair or a very small part of a single gene

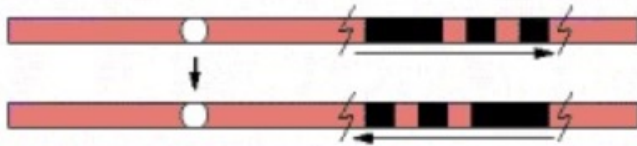

INVERSION: inverts a segment of a chromosome

lethal mutation: causes the developing organism to die prematurely.

conditional mutation: produces its phenotypic effect only under certain conditions, called the *restrictive* conditions. Under other conditions—the *permissive* conditions—the effect is not seen. For a *temperature-sensitive* mutation, the restrictive condition typically is high temperature, while the permissive condition is low temperature.

loss-of-function mutation: either reduces or abolishes the activity of the gene. These are the commonest class of mutations. Loss-of-function mutations are usually *recessive*—the organism can usually function normally as long as it retains at least one normal copy of the affected gene.

null mutation: a loss-of-function mutation that completely abolishes the activity of the gene.



DELETION: deletes a segment of a chromosome

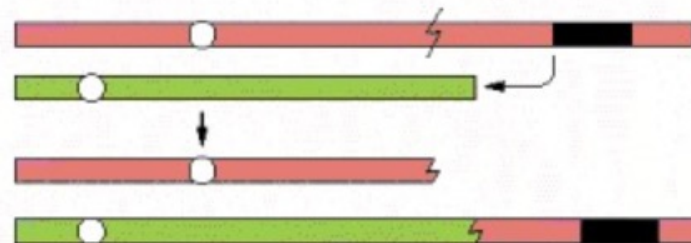

TRANSLOCATION: breaks off a segment from one chromosome and attaches it to another

gain-of-function mutation: increases the activity of the gene or makes it active in inappropriate circumstances; these mutations are usually *dominant*.

dominant negative mutation: dominant-acting mutation that blocks gene activity, causing a loss-of-function phenotype even in the presence of a normal copy of the gene. This phenomenon occurs when the mutant gene product interferes with the function of the normal gene product.

suppressor mutation: suppresses the phenotypic effect of another mutation, so that the double mutant seems normal.





An *intragenic* suppressor mutation lies within the gene affected by the first mutation; an *extragenic* suppressor mutation lies in a second gene—often one whose product interacts directly with the product of the first.

Mutagenesi inserzionale mediata da elementi trasponibili

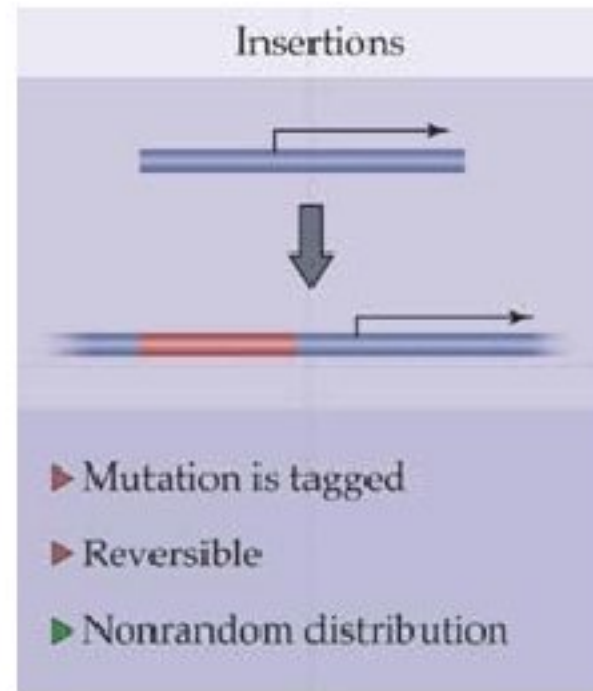
Facile mappatura dell'inserzione

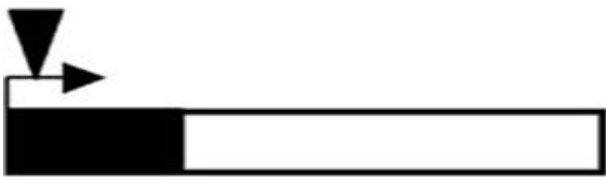
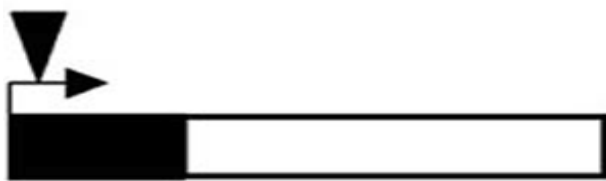
Rapido clonaggio del gene mutato



	Posizione	Risultato
	ORF o promotore	KO
	Promotore o 3' UTR	espressione ridotta
	Promotore	espressione aumentata
	ORF	non nullo
	ORF o promotore multipli	KO
	ORF o promotore	Riarrangiamento cromosomico

Strategia di Isolamento Mutanti Inserzionali

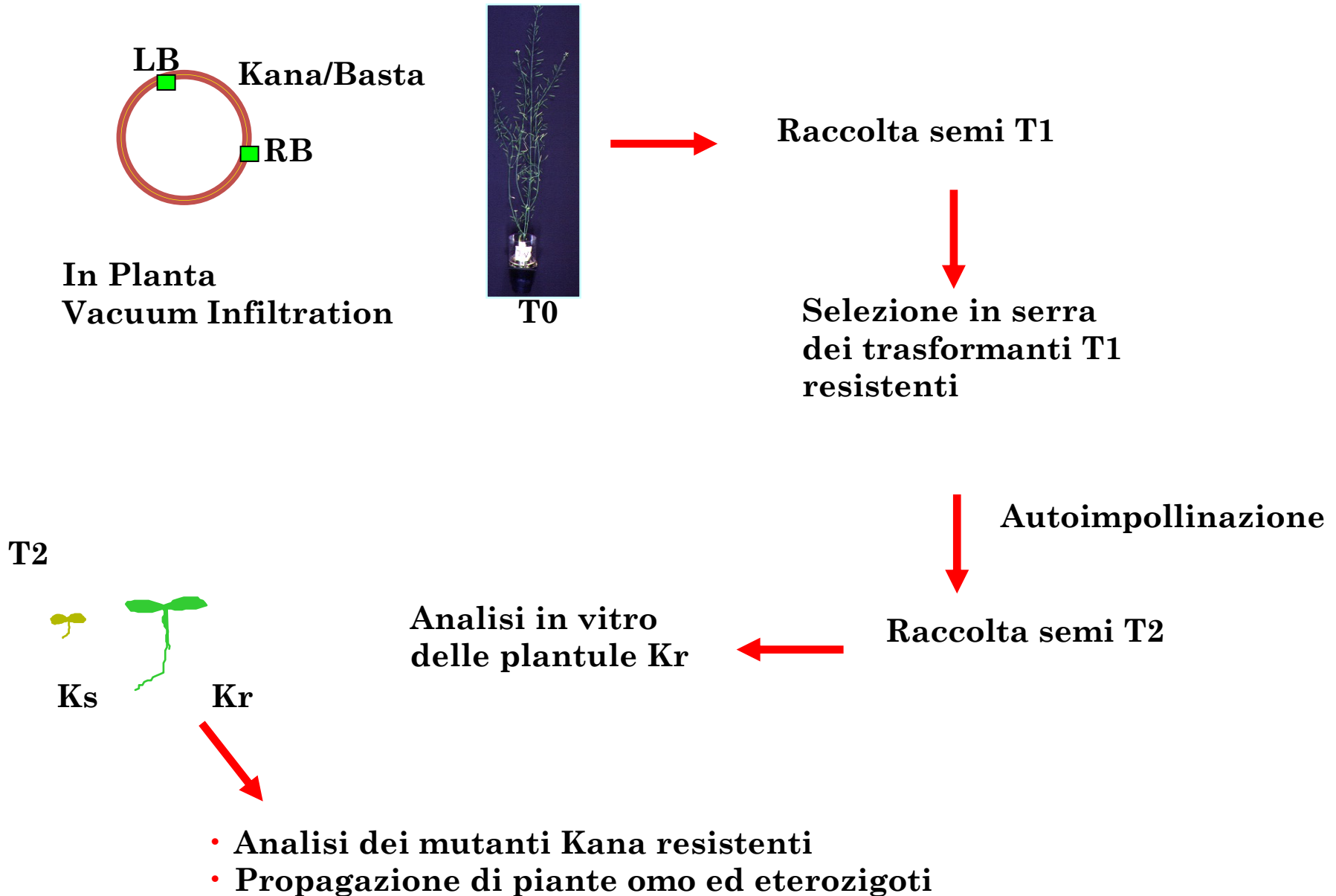

**Ma il T-DNA è correlato
(responsabile del) con il fenotipo mutato???**

- **Analisi di segregazione
del marcatore e eventualmente del fenotipo mutante
(inserzione T-DNA in 1 o più loci??)**
- **Caratterizzazione molecolare del sito di inserzione
(T-DNA singolo, a tandem oppure inserzione più complessa??)**
- **Clonaggio delle “Flanking Sequences”**

Analisi di segregazione

Fenotipo «selvatico»				
<u>T2 Plants</u>	aa(Kr/Kr)	Aa(Kr/Ks)	AA(Ks/Ks)	Total
	96	193	94	383
	1	2	1	

autoimpollinazione

<u>T3 Plants</u>	aa(Kr)	Aa(Kr/Ks)	Ks	Total
a	24	47	26	97
b	25	46	24	95
c	27	55	28	110
e	121	0	0	121

aa gene inattivo in omozigosi

Aa una copia gene inattiva, una selvatica

**Ma il T-DNA è correlato
(responsabile del) con il fenotipo mutato???**

- **Analisi di segregazione
del marcatore e del fenotipo mutante
(inserzione T-DNA in 1 o più loci??)**
- **Caratterizzazione molecolare del sito di inserzione
(T-DNA singolo, a tandem oppure inserzione più complessa??)**
- **Clonaggio delle “Flanking Sequences”**

pGKB5 T-DNA

X

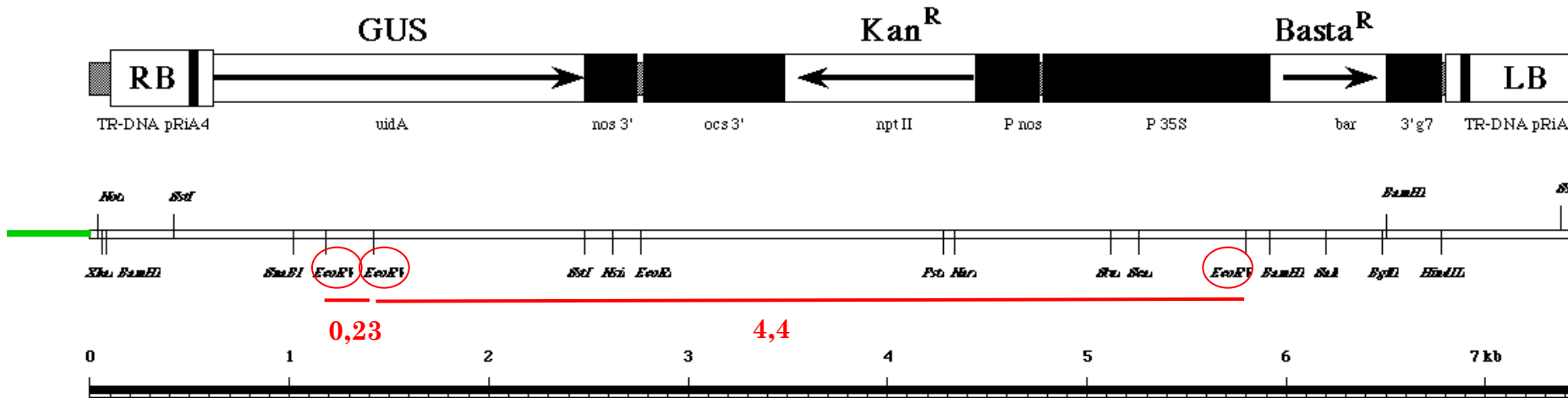

probe

Digestione EcoRV:

0.23 Kb e 4,4 Kb interne al T-DNA

X Kb fino al sito EcoRV sulla flanking sequence

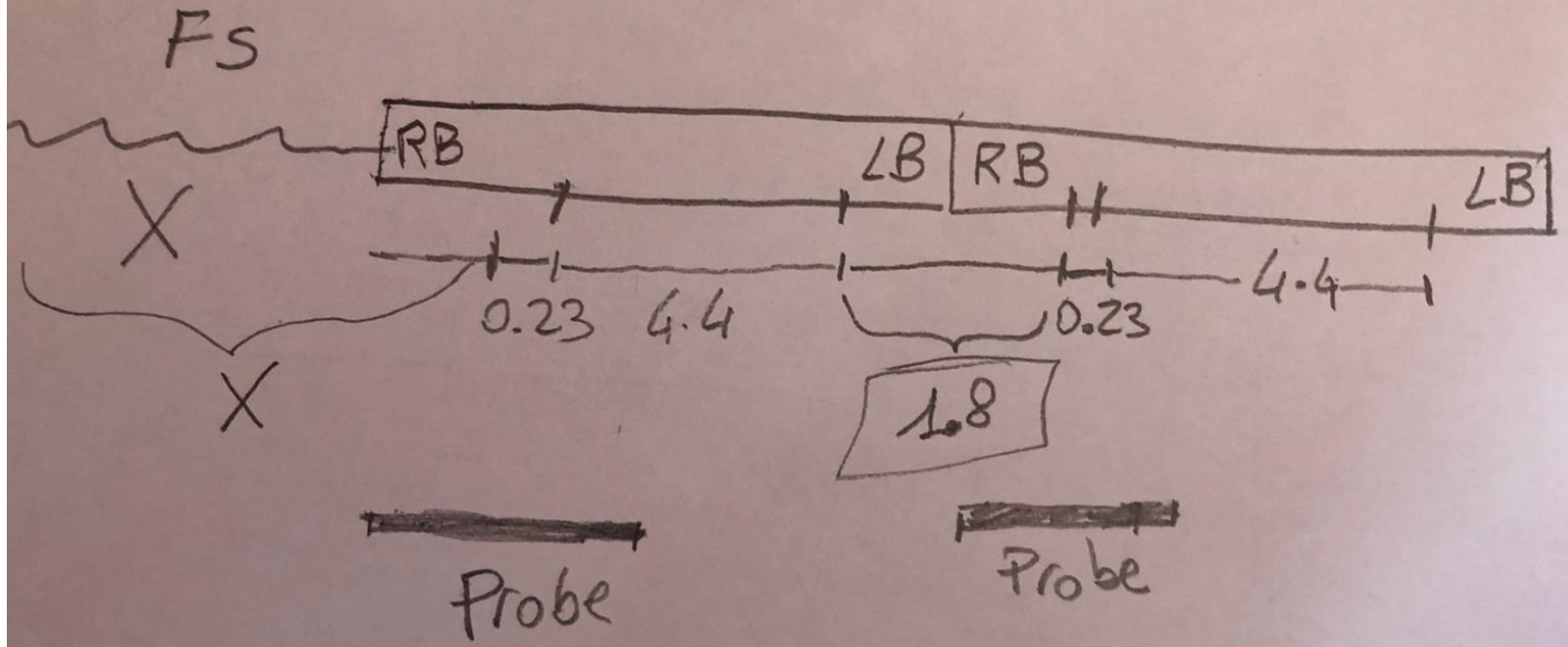

Coda-Coda



Testa-Coda

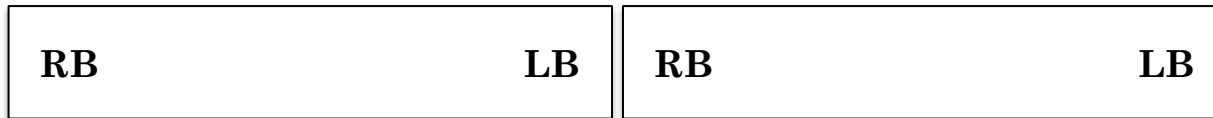

**Ma il T-DNA è correlato
(responsabile del) con il fenotipo mutato???**

- **Analisi di segregazione
del marcatore e del fenotipo mutante
(inserzione T-DNA in 1 o più loci??)**
- **Caratterizzazione molecolare del sito di inserzione
(T-DNA singolo, a tandem oppure inserzione più complessa??)**
- **Clonaggio delle “Flanking Sequences”**

Strategie di clonaggio delle “Flanking Sequences”

- **Plasmid Rescue**
- **Inverse PCR (IPCR)**
- **Libreria genomica del mutante
(probe T-DNA)**

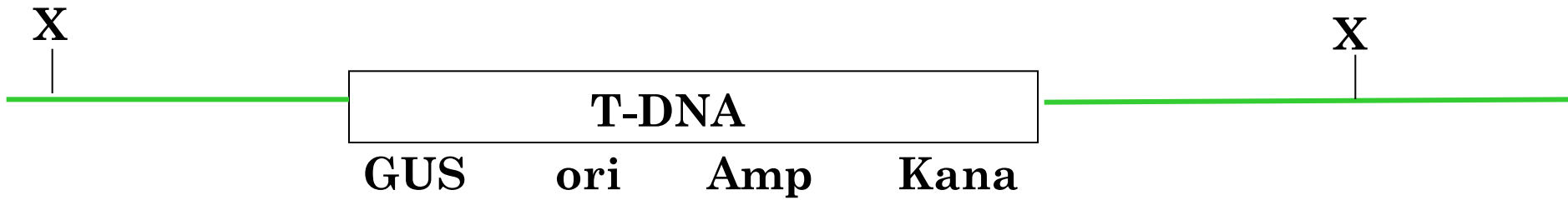

Digestione



Ligazione intramolecolare

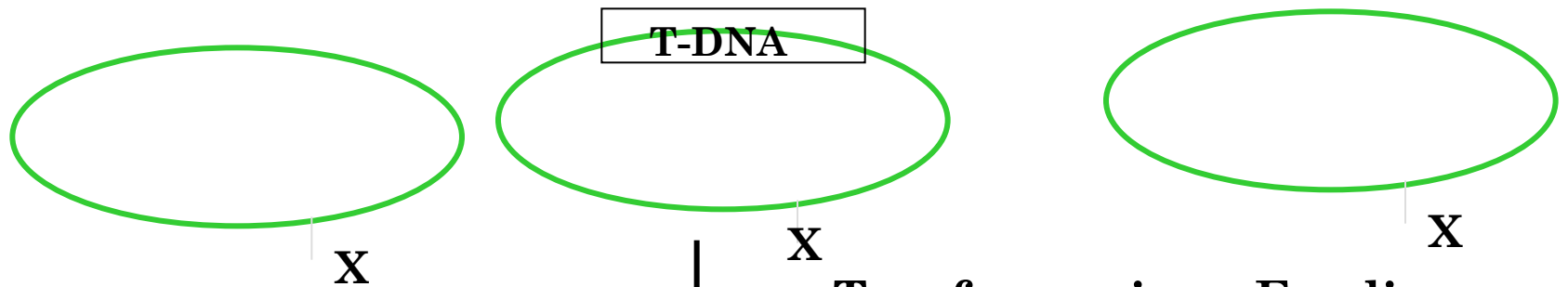

Trasformazione E.coli

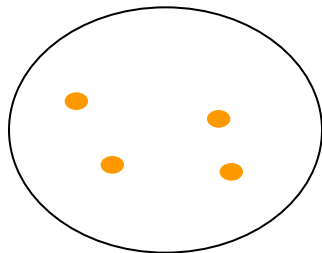

Selezione colonie Amp^R, su LB+Amp

Strategie di clonaggio delle “Flanking Sequences”

- **Plasmid Rescue**
- **Inverse PCR (IPCR)**
- **Libreria genomica del mutante
(probe T-DNA)**



Digestione

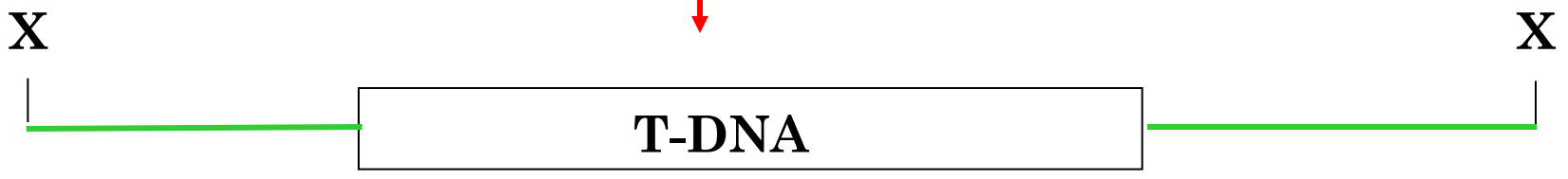

Ligazione intramolecolare

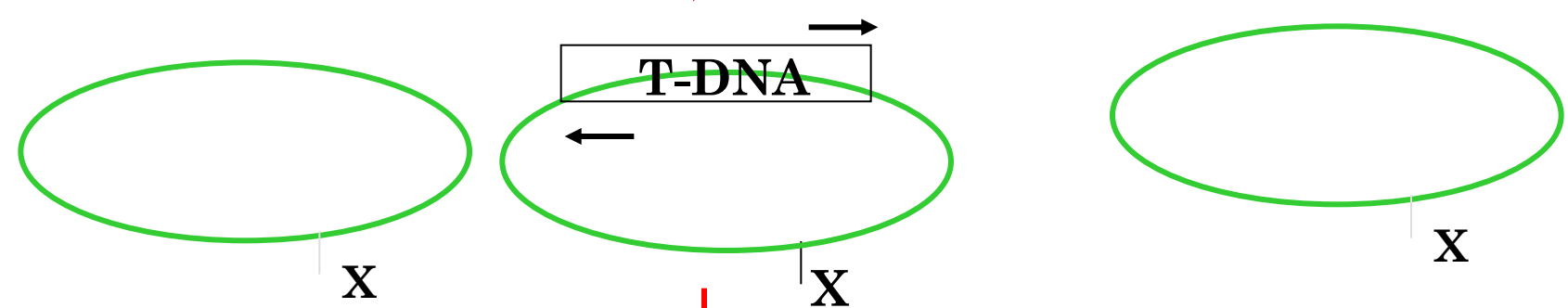

PCR



Gene Targeting in Mice/hES cells

Il Gene Targeting è mediato da Ricombinazione omologa

Nelle cellule di mammifero la ricombinazione omologa è un evento molto raro (a differenza del lievito)

La frequenza di questo evento aumenta se il grado di omologia di sequenza

tra il DNA introdotto (esogeno) e il gene bersaglio (endogeno) è molto elevata

Per questo il clone di DNA esogeno è una sequenza isogenica (derivante dallo stesso ceppo murino)

Gene targeting mediante ricombinazione omologa

Comporta l'introduzione di una mutazione in un gene specifico e può essere considerata come una forma di "site-directed in vivo mutagenesis" e quindi è utilizzata per lo studio della funzione genica

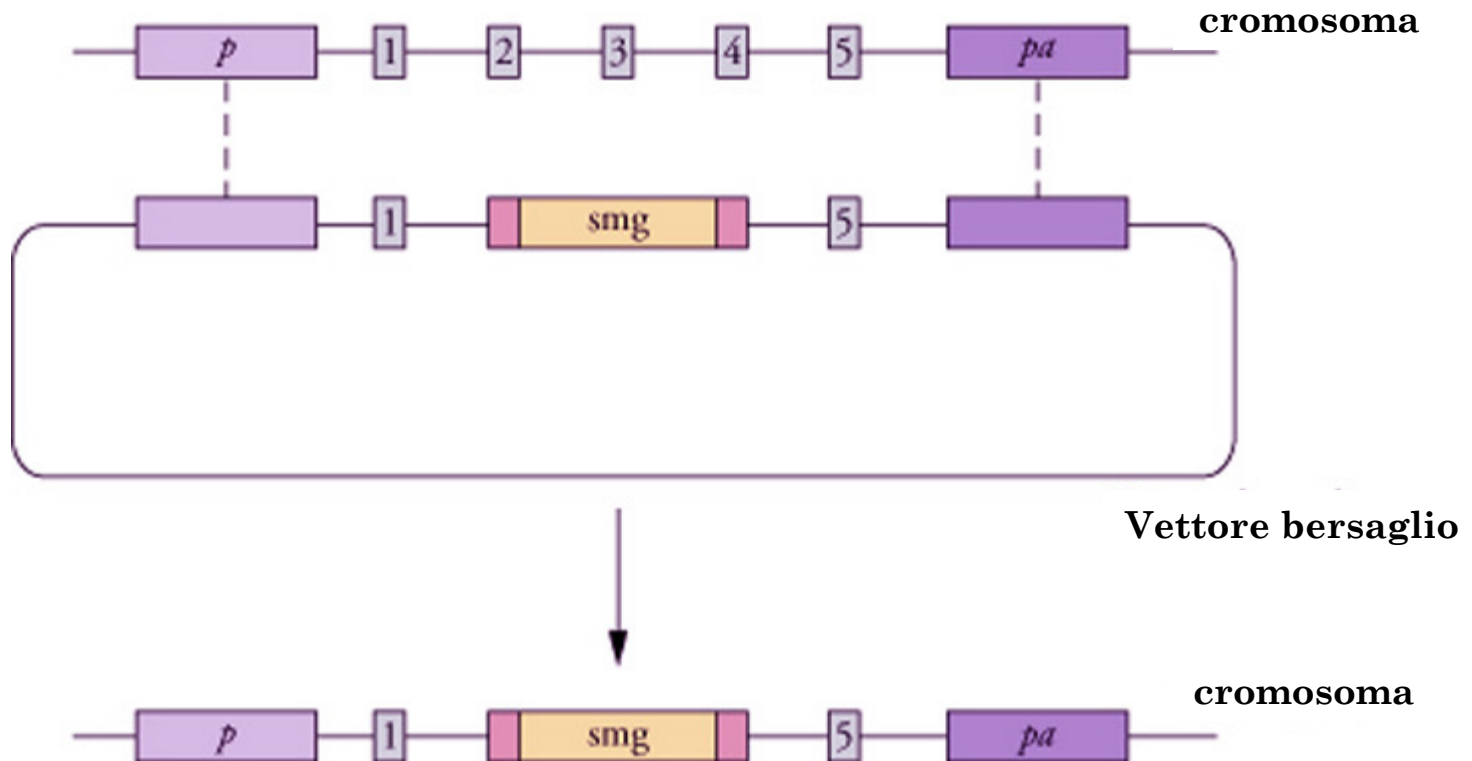

SELEZIONE POSITIVA-NEGATIVA cellule ES

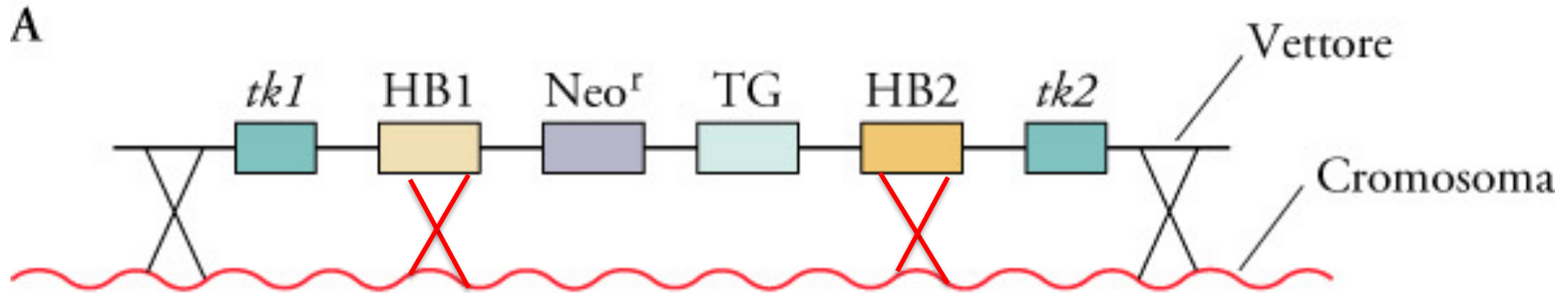

Seq di DNA per RICOMBINAZIONE OMOLOGA nel genoma bersaglio

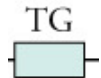

TRANSGENE di interesse



Gene che conferisce resistenza alla G418

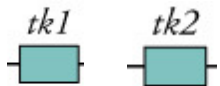

Geni della Timidina Kinasi (virus herpes simplex). In presenza di GANCICLOVIR: MORTE

SELEZIONE POSITIVA e NEGATIVA

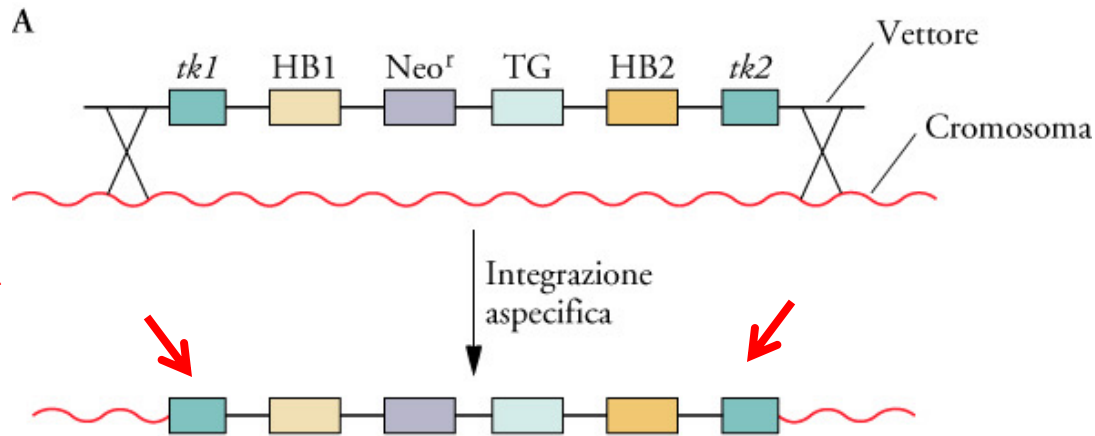

ASPECIFICA

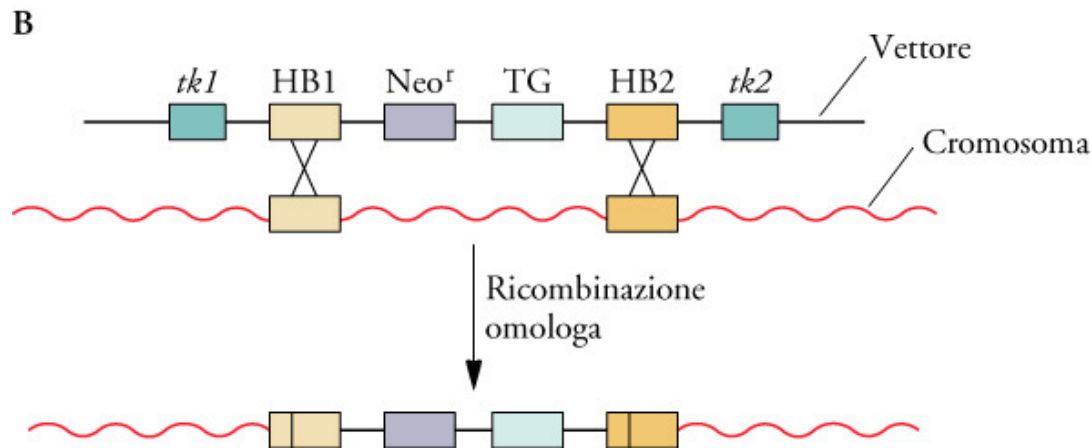

SPECIFICA

- 1) Aggiunta di **G418**: SELEZIONE POSITIVA di cellule che hanno INTEGRATO il DNA
- 2) Aggiunta di **GANCICLOVIR**: SELEZIONE NEGATIVA di cellule con INTEGRAZIONE ASPECIFICA

La selezione positiva/negativa

A: risultato di integrazione aspecifica. Si selezionano le cellule positivamente per la resistenza a G-418, conferita dal gene Neo, e negativamente in presenza del gancyclovir, che viene trasformato dalla timidina chinasi in composti tossici. Le cellule contenenti il vettore inserito random (A) conterranno il gene TK, e saranno uccise in presenza di gancyclovir

B: risultato di ricombinazione omologa. Il prodotto del doppio crossover tra i blocchi omologhi HB1 e HB2 non contiene i due geni della timidina kinasi (tk1 e tk2), quindi sono resistenti al gancyclovir, e anche al G-418 grazie alla presenza del gene Neo.

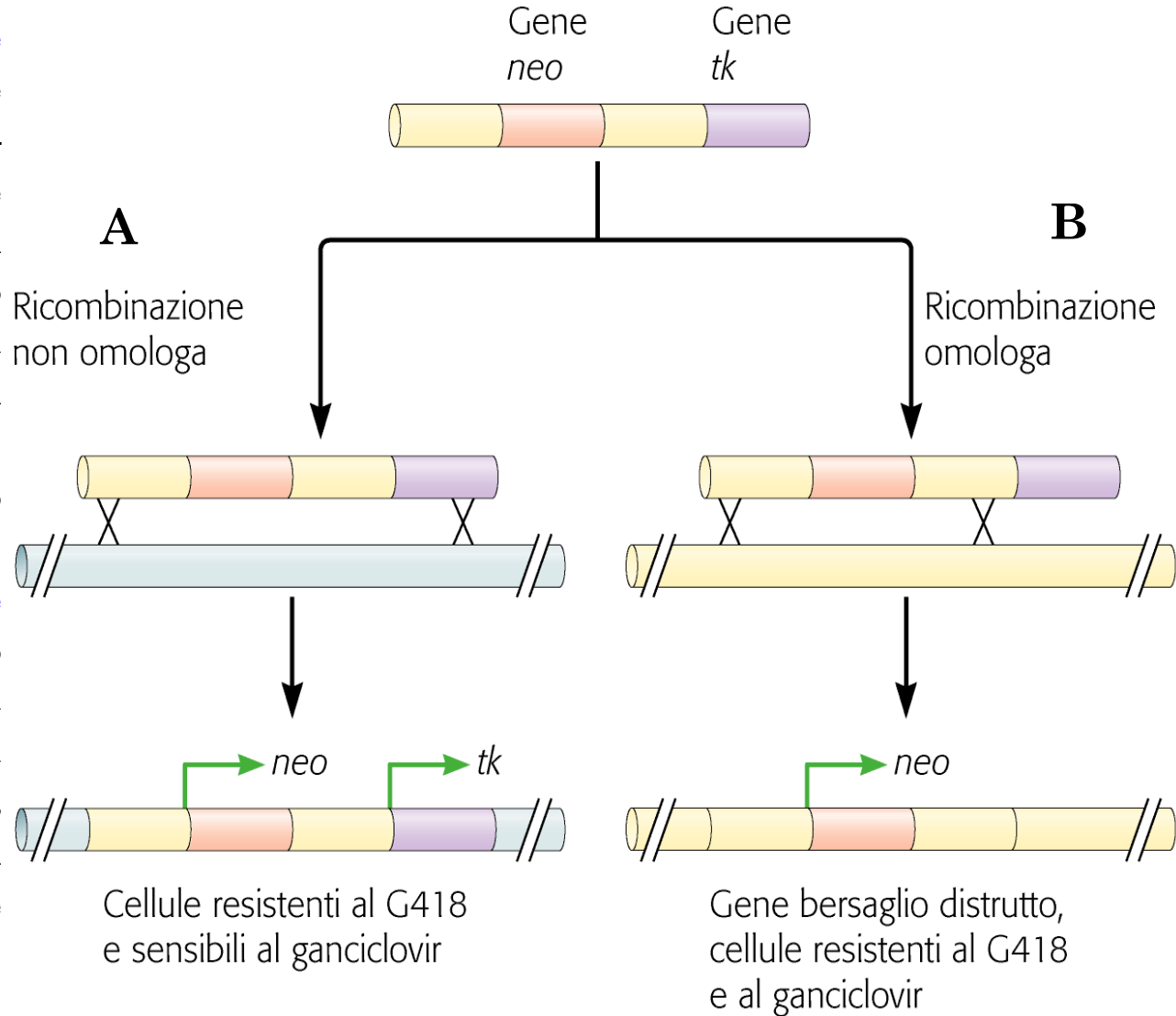

Analisi dell'integrazione mediante PCR

A: integrazione aspecifica

Uno dei primers (P2) non è in grado di appaiarsi al sito cromosomico P2. P1 invece si ibrida ad una sequenza US che si trova sul DNA esogeno.

Quindi non si ha amplificazione

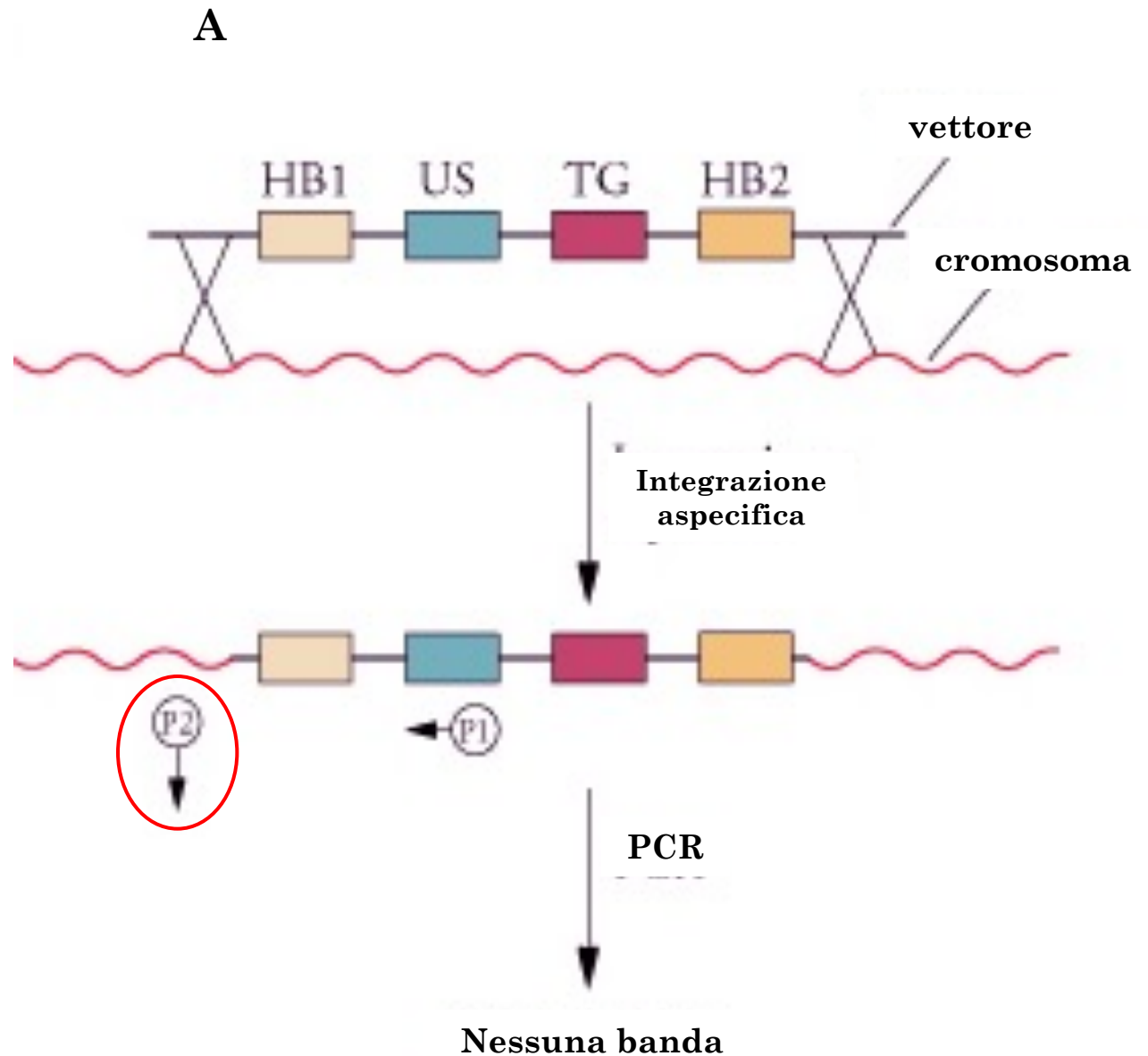

Analisi dell' integrazione mediante PCR

B: ricombinazione omologa

La ricombinazione omologa tra le sequenze di DNA HB1 e HB2 del DNA esogeno che sono complementari ai siti cromosomici CS1 e CS2, crea regioni di ibridazione per P1 e P2 che si trovano ad una distanza predeterminata. L' amplificazione così genera il prodotto di dimensioni attese.

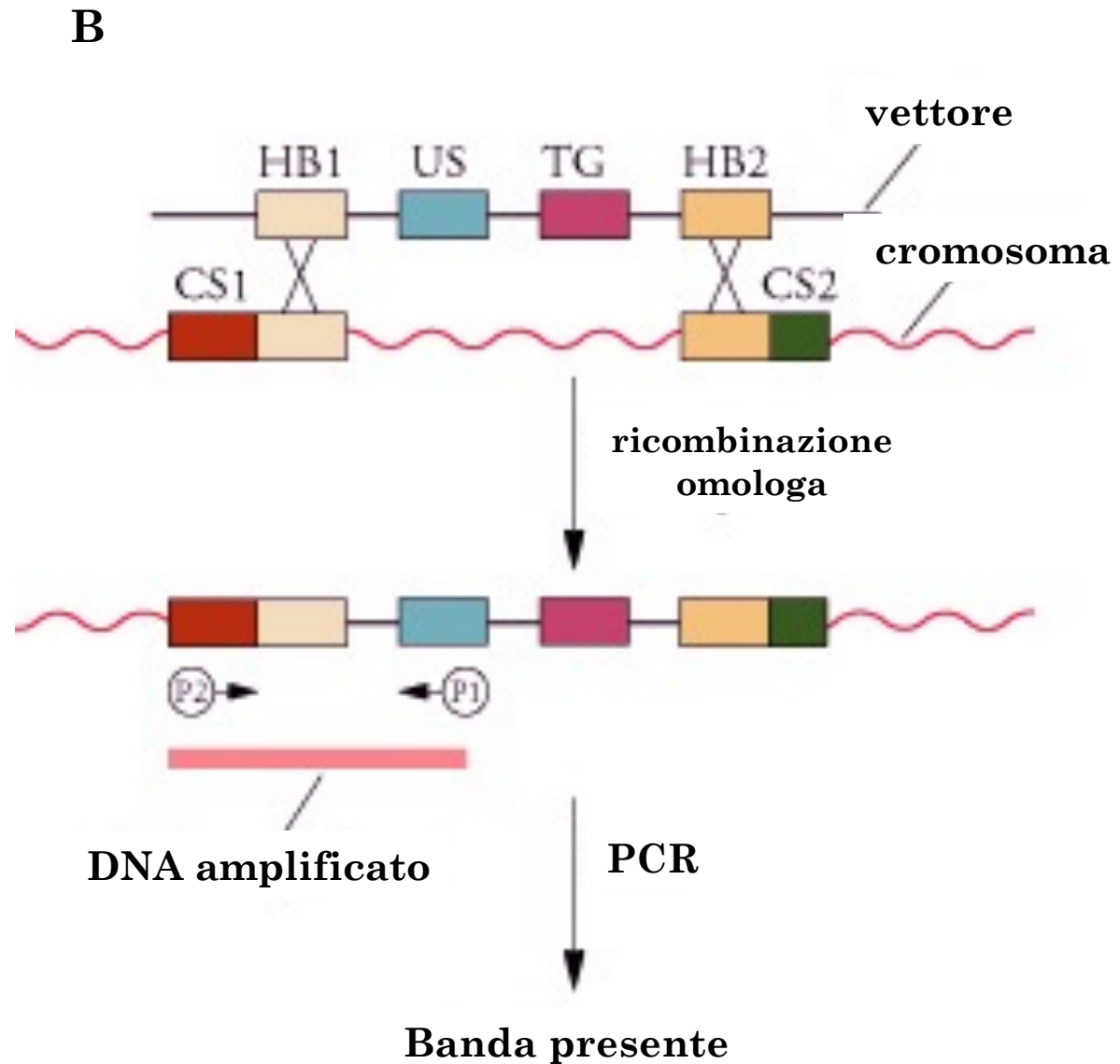

Cre-Lox System

Il sistema Cre/Lox deriva dal fago P1

Il sistema è detto “floxing” in quanto consiste di sequenze fiancheggianti il gene e la ricombinazione mediata da Cre

Cre: Ricombinasi sequenza-specifica (catalizza la ricombinazione tra siti Lox)

LoxP: Locus di crossover (2 palindromi 13bp + regione centrale di 8nt)

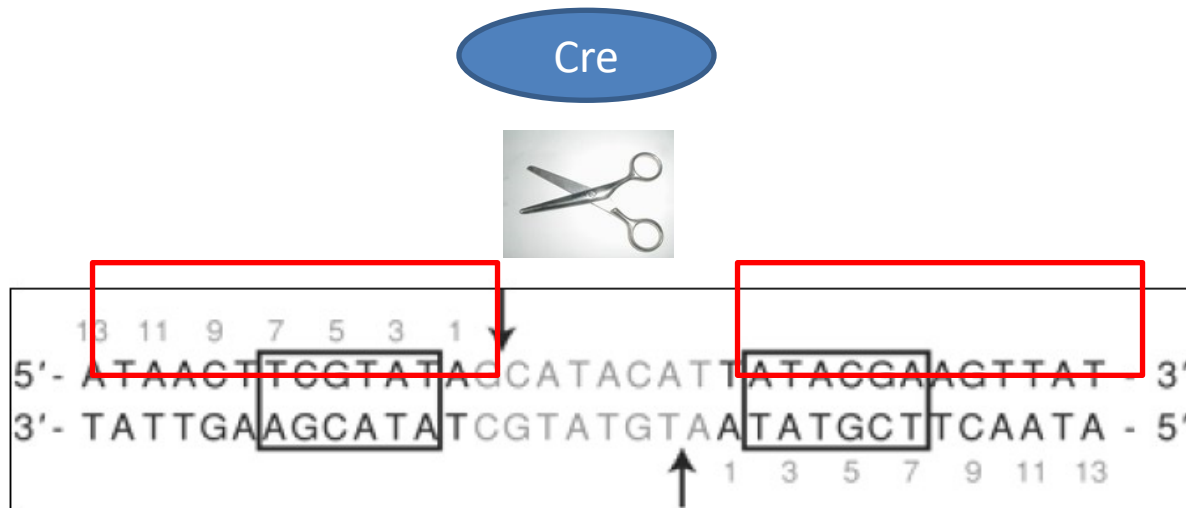

la ricombinasi CRE riconosce i siti LoxP e ricombina le sequenze di DNA adiacenti

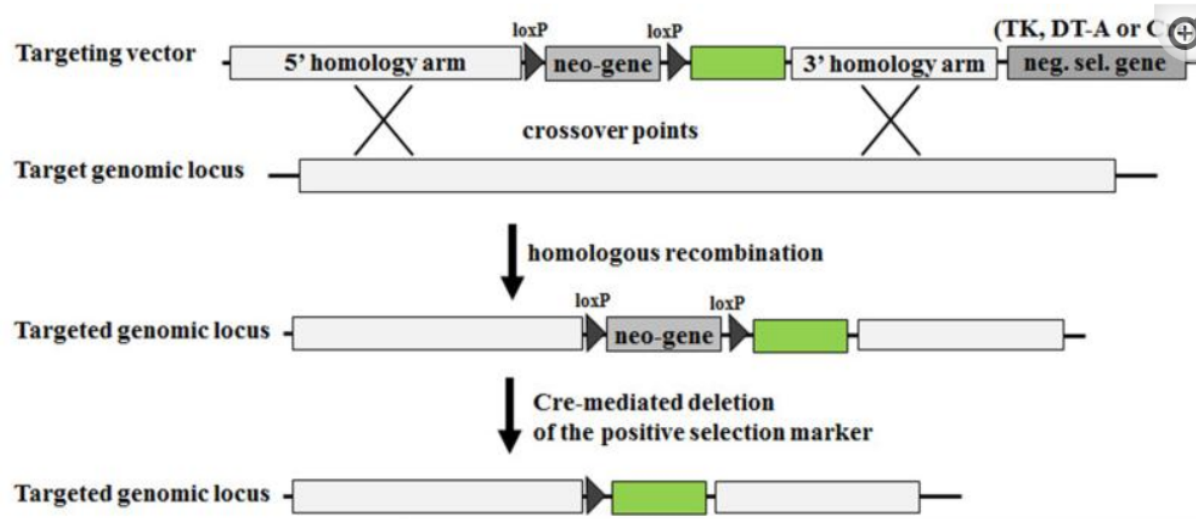

Typical gene targeting strategy

A targeting vector is typically composed of three basic units: (i) a 5' homology arm; (ii) a gene marker for positive selection (e.g. neomycin resistance gene (neo)); (iii) a 3' homology arm; and (iv) a negative selection marker (neg. sel. Marker), such as thymidine kinase, diphtheria toxin fragment A (DT-A), or, if the positive selection marker is flanked by loxP sites, Cre recombinase gene (Cre). Furthermore, any desired DNA sequence of interest (here green box) can be inserted between the homology arms of the targeting vector, in order to introduce it into the target genome by homologous recombination. Homologous recombination between the targeting vector and the target cognate chromosomal region results in the disruption of one genomic copy of the targeted genomic locus and loss of the vector's negative selection marker gene. Crossover points are depicted by "X". The floxed (loxP sites flanked) positive selection marker gene can be removed by expressing Cre recombinase in the recombinant ESCs or by crossing the chimeric mice with Cre-expressing transgenic mice (see also [Fig. 4A](#)).

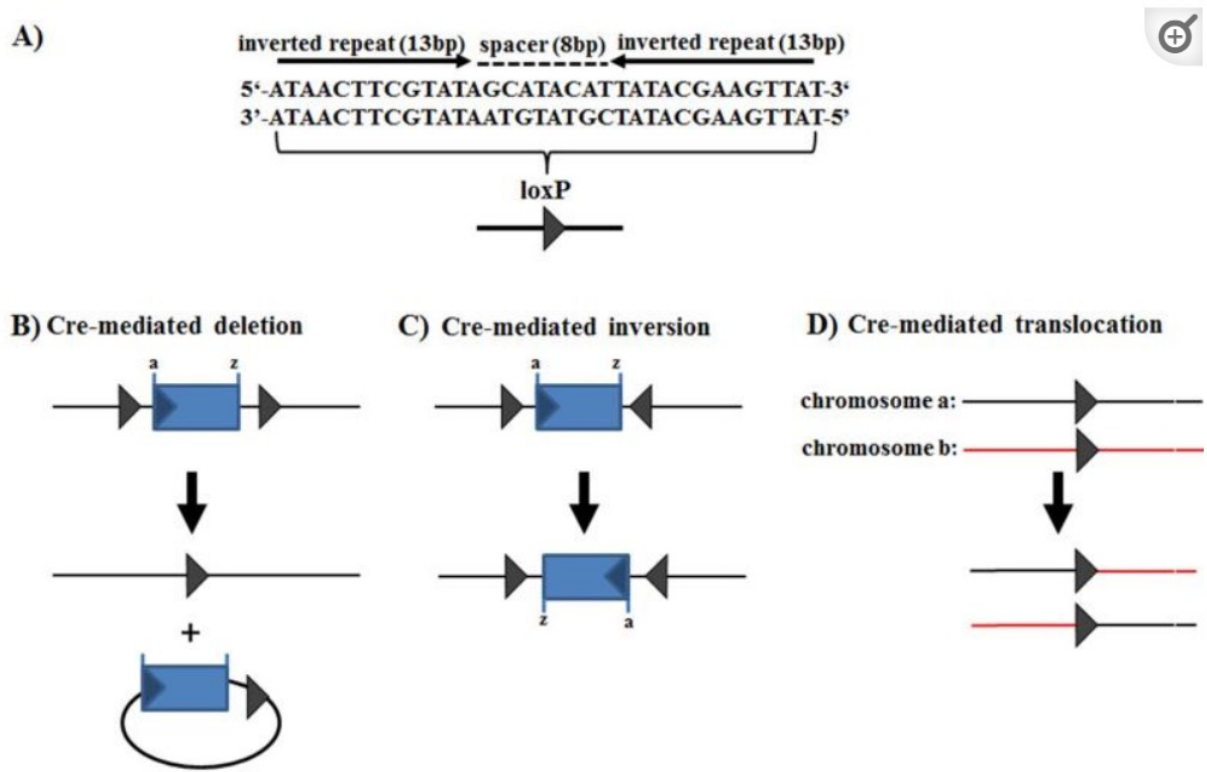

LoxP structure and Cre recombinase-mediated recombinations

(A) Single loxP site that contains two inverted 13 bp repeats, separated by an asymmetric 8 bp long sequence. The type of Cre-mediated recombination is dependent on the orientation and location of the loxP sites: **(B)** Cre excises a circular molecule from between two loxP sites placed in the same orientation; **(C)** Cre inverts the DNA sequence between two loxP sites positioned in opposite orientation; **(D)** Cre-mediated recombination between two different linear DNA molecules (e.g. chromosomes), each containing a loxP site, resulting in the exchange of the DNA regions flanking the loxP sites. Figure was modified from Torres and Kuehn ([111](#)).

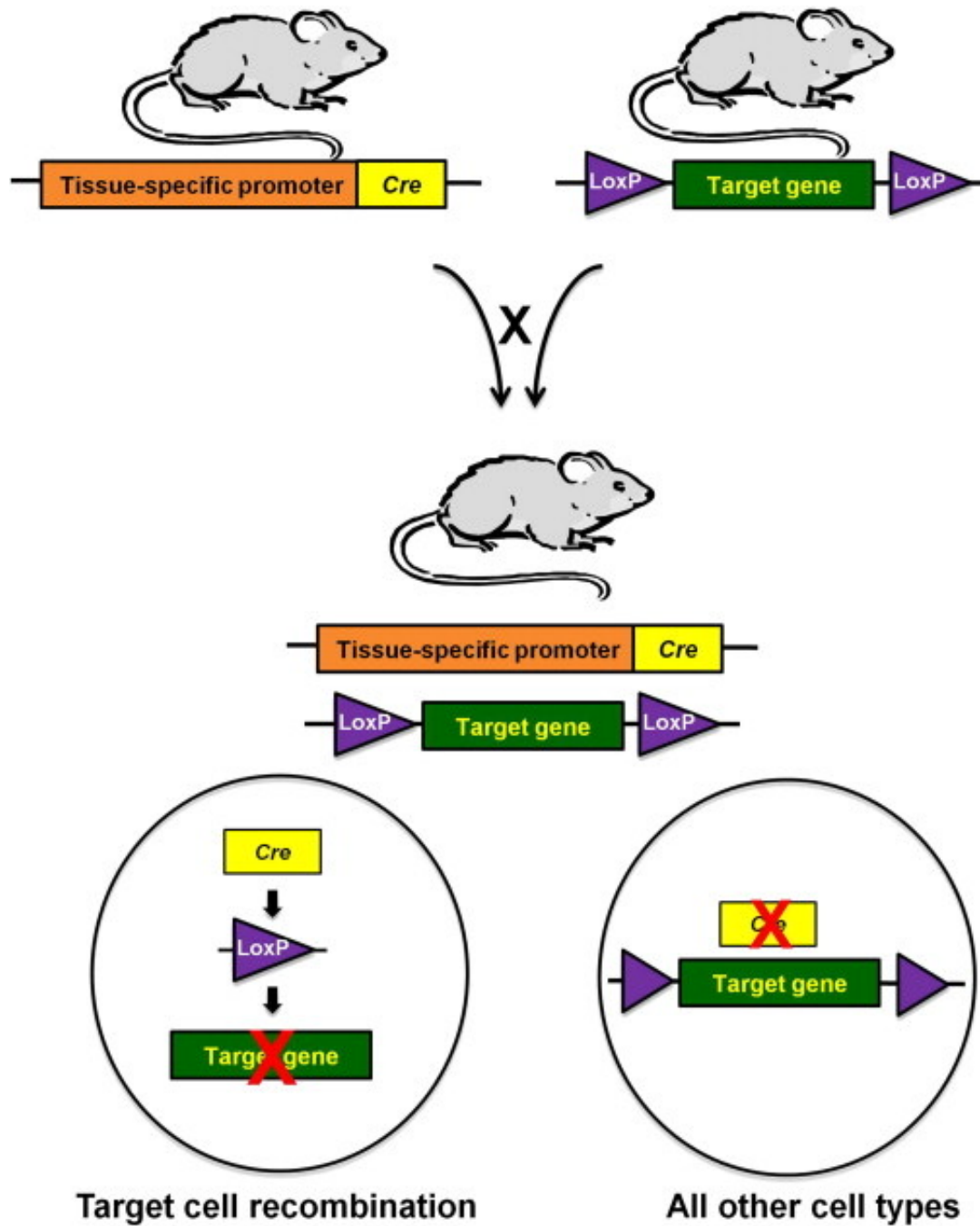

Target cell recombination

All other cell types

Cre-lox *Tissue-Specific* Knockout

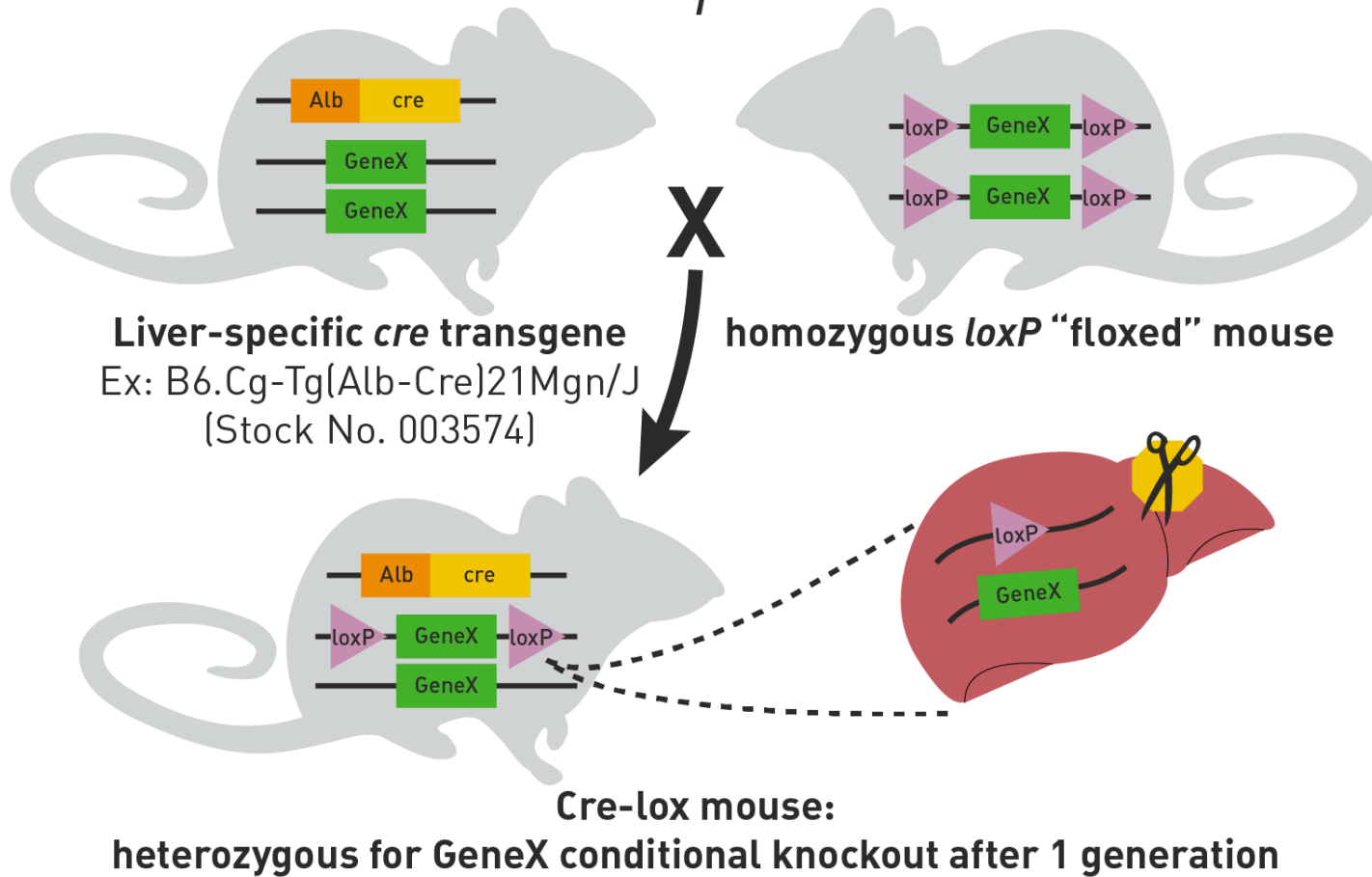

Approximately 50% of the offspring will be heterozygous for the loxP allele and heterozygous for the cre transgene. Mate these mice back to the homozygous *loxP*-flanked mice. Approximately 25% of the progeny from this mating will be homozygous for the *loxP*-flanked allele and heterozygous for the *cre* transgene. These will be your experimental mice.

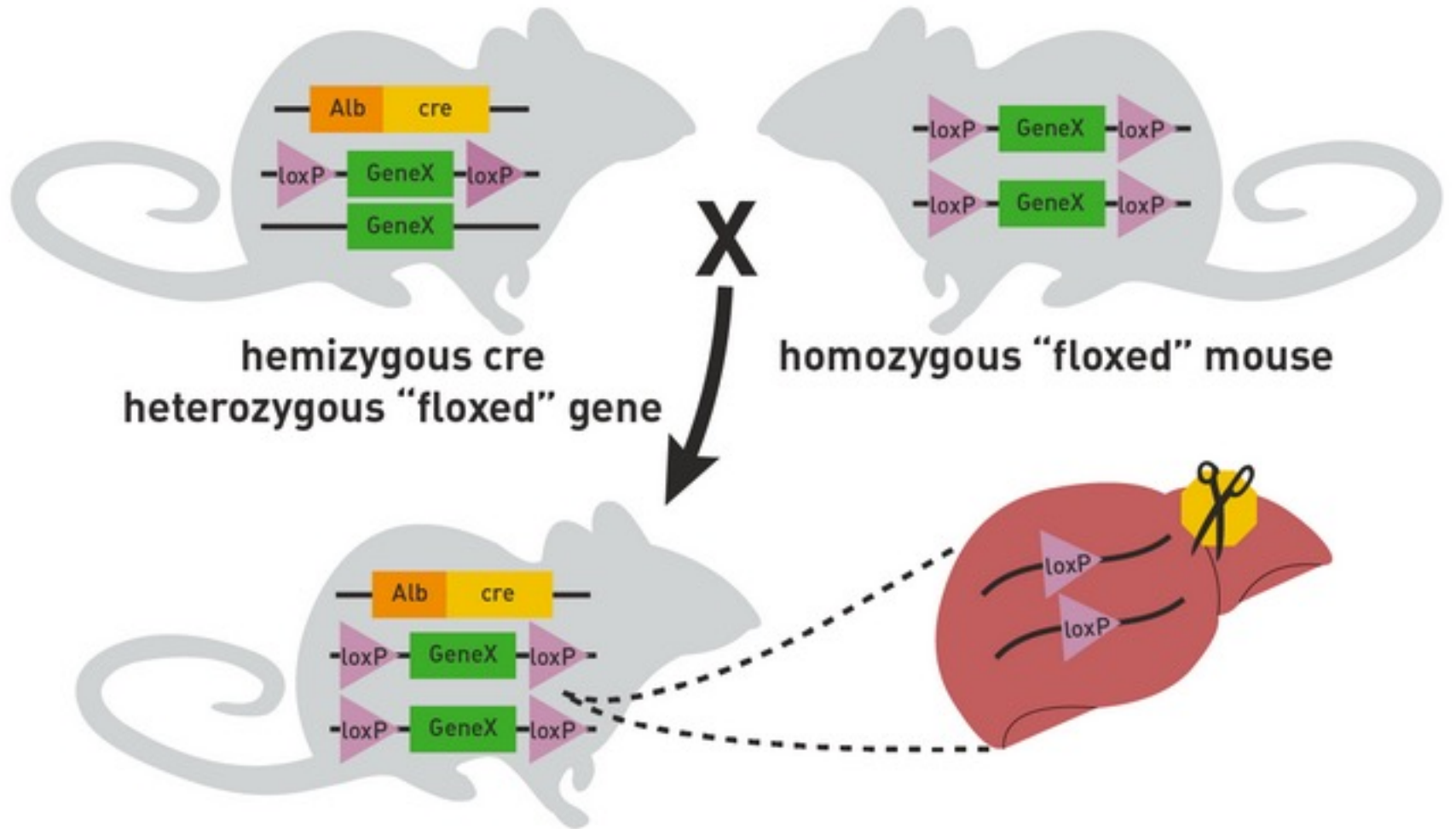

F₀ Generation

Cre Mouse

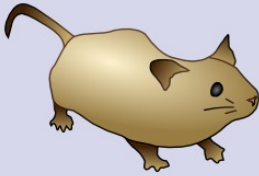

LoxP (Floxed) Mouse

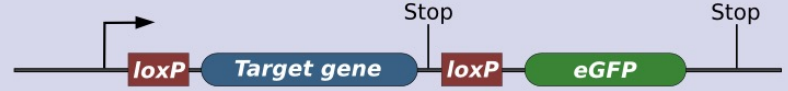
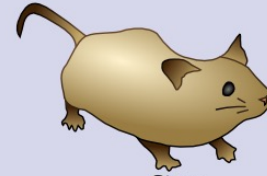

Cre LoxP Mouse

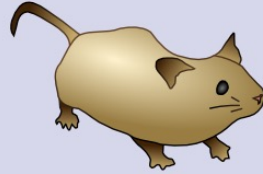

F₁ Generation

Cells with active Cre recombinase

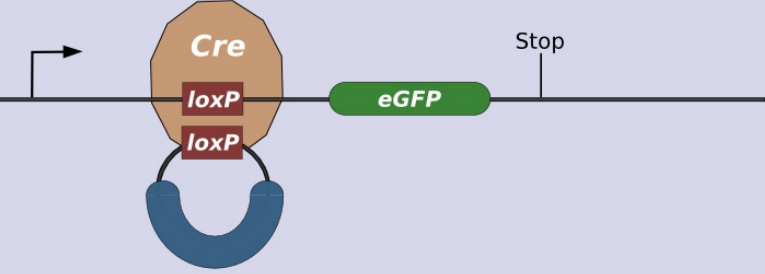

Cells lacking active Cre recombinase

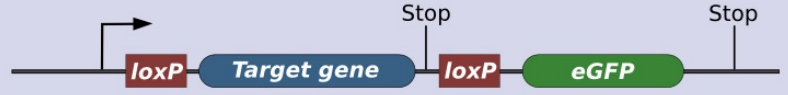

Original gene function is disrupted, a reporter gene is transcribed instead.

Original gene function is untouched.

Espressione/Delezione di un gene inducibile

Sono state prodotte proteine di fusione tra Cre e ER(T) (recettore estrogeni). La ricombinasi è confinata nel citoplasma finché non viene somministrato l'ormone sintetico che riconosce il recettore e fa traslocare la proteina di fusione con la ricombinasi nel nucleo dove induce la delezione del frammento incluso tra i due siti LoxP

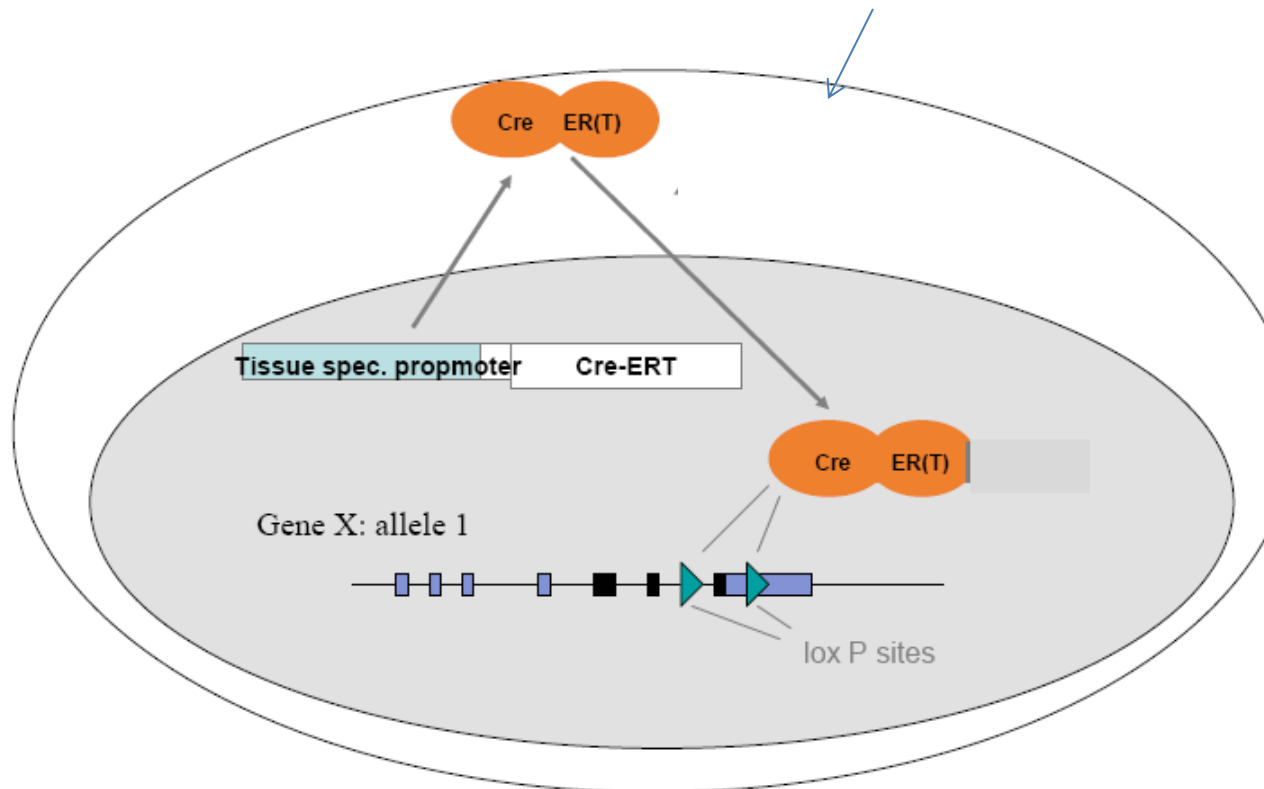

Reverse Genetics

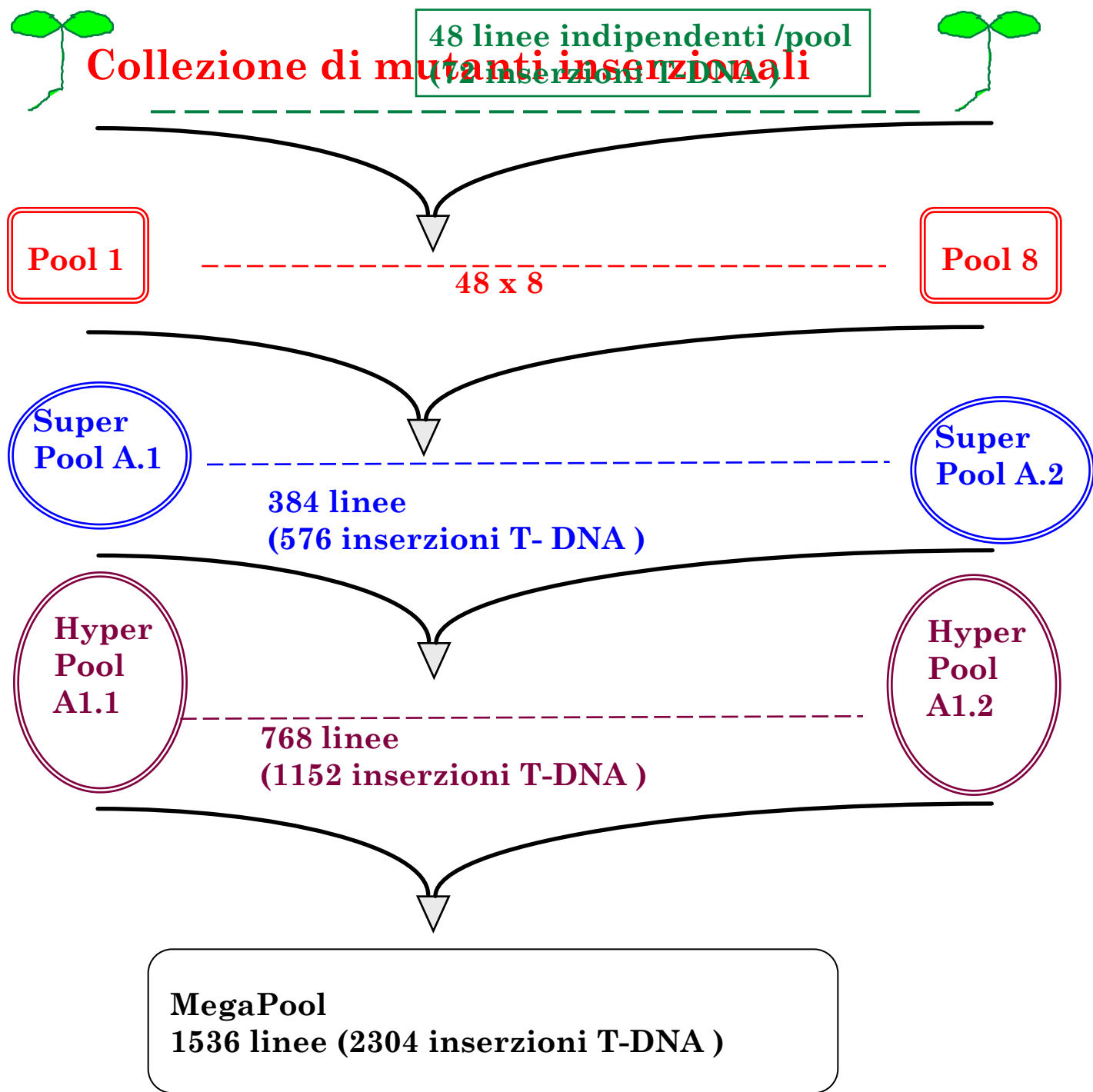

Protocollo di Screening mediante PCR

- **Screening per PCR di n HP:**
combinazione di un primer gene-specifico (F/R)
ed un primer T-DNA (RB/LB)
- **Qualità dei primers:** specificità-sensibilità
background con i primers T-DNA
- **Analisi per ibridazione (transfer “sandwich”):**
sonda T-DNA (RB+LB)
sonda gene-specifica
- **Segnali coincidenti con le 2 sonde:**
PCR di conferma con primers T-DNA nested
o con primers gene-specifici
sequenza del frammento amplificato

Scelta dei Primers gene-specifici

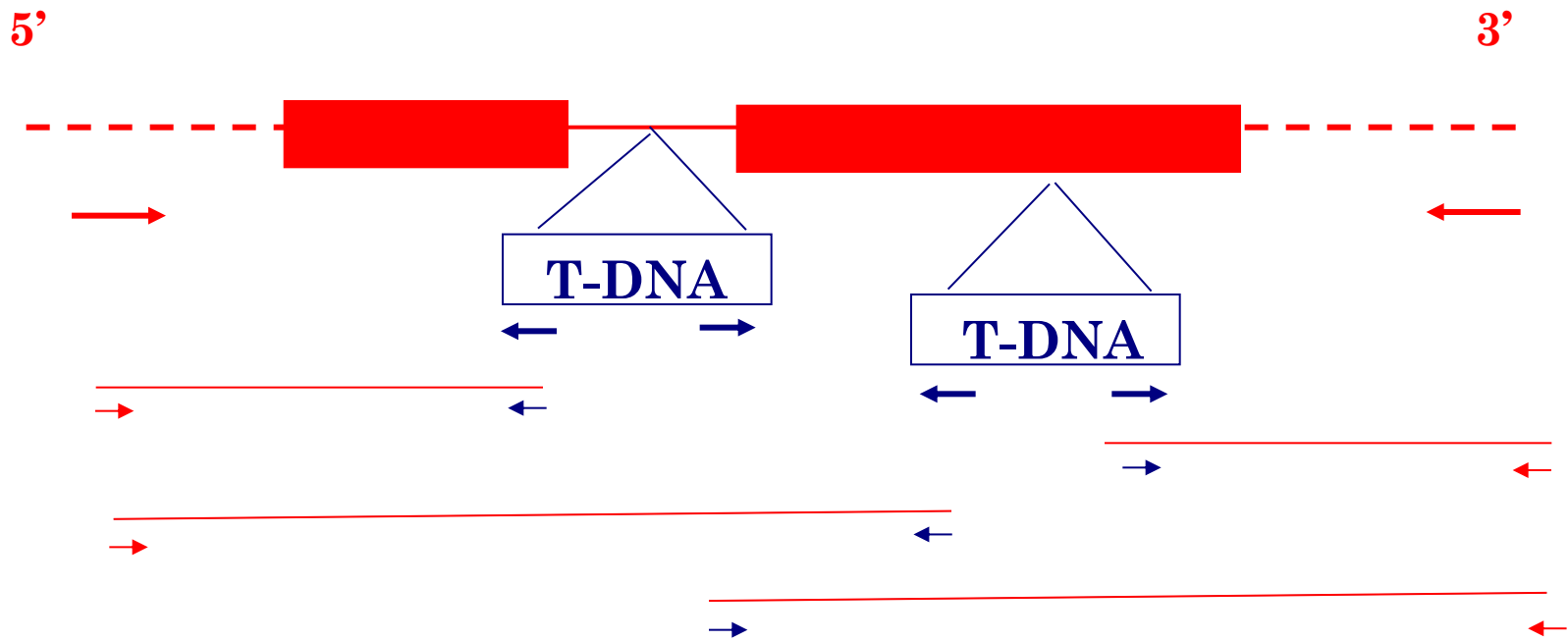

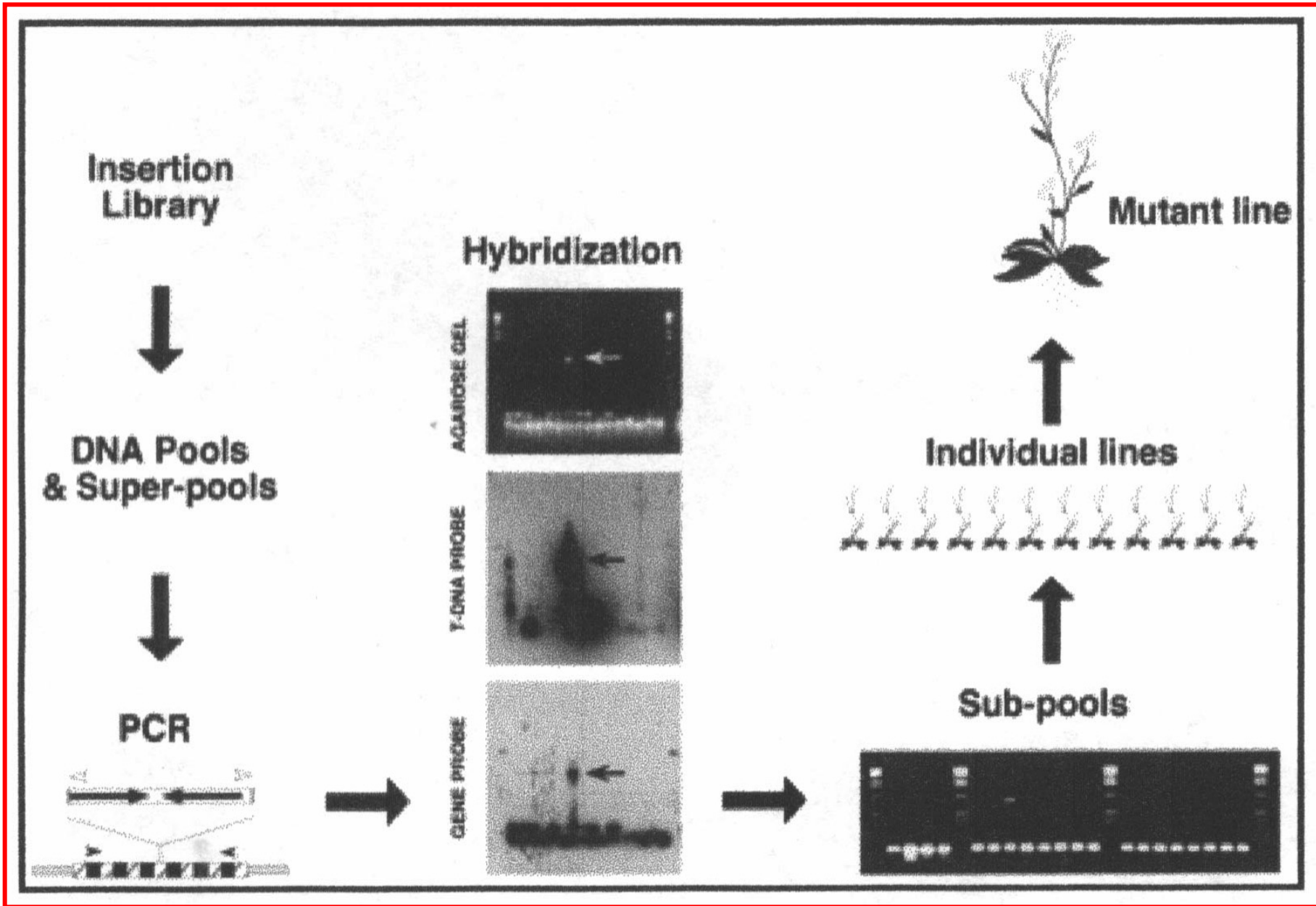

Sonda DAG1

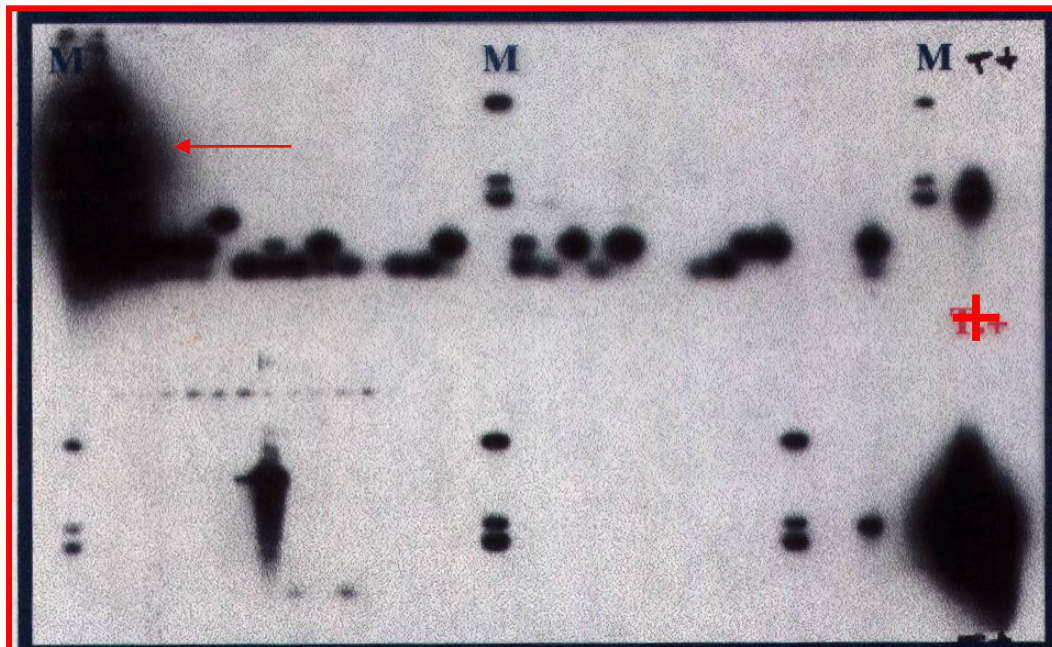

Sonda T-DNA

