

# Hazard and operability studies (HAZOP studies) — Application guide

ICS 29.020

## National foreword

This British Standard reproduces verbatim IEC 61882:2001 and implements it as the UK national standard.

The UK participation in its preparation was entrusted to Technical Committee DS/1, Dependability and terotechnology, which has the responsibility to:

- aid enquirers to understand the text;
- present to the responsible international/European committee any enquiries on the interpretation, or proposals for change, and keep the UK interests informed;
- monitor related international and European developments and promulgate them in the UK.

A list of organizations represented on this committee can be obtained on request to its secretary.

From 1 January 1997, all IEC publications have the number 60000 added to the old number. For instance, IEC 27-1 has been renumbered as IEC 60027-1. For a period of time during the change over from one numbering system to the other, publications may contain identifiers from both systems.

### Cross-references

The British Standards which implement international publications referred to in this document may be found in the BSI Standards Catalogue under the section entitled "International Standards Correspondence Index", or by using the "Find" facility of the BSI Standards Electronic Catalogue.

A British Standard does not purport to include all the necessary provisions of a contract. Users of British Standards are responsible for their correct application.

**Compliance with a British Standard does not of itself confer immunity from legal obligations.**

This British Standard, having been prepared under the direction of the Management Systems Sector Policy and Strategy Committee, was published under the authority of the Standards Policy and Strategy Committee and comes into effect on 28 August 2001

### Summary of pages

This document comprises a front cover, an inside front cover, the IEC title page, pages 2 to 57, and a back cover.

The BSI copyright date displayed in this document indicates when the document was last issued.

### Amendments issued since publication

Amd. No.	Date	Comments

© BSI 28 August 2001

ISBN 0 580 37625 7

**NORME  
INTERNATIONALE  
INTERNATIONAL  
STANDARD**

**CEI  
IEC**

**61882**

Première édition  
First edition  
2001-05

---

---

**Etudes de danger et d'exploitabilité  
(études HAZOP) –  
Guide d'application**

**Hazard and operability studies  
(HAZOP studies) –  
Application guide**



Numéro de référence  
Reference number  
CEI/IEC 61882:2001

## CONTENTS

FOREWORD .....	4
INTRODUCTION .....	5
1 Scope .....	6
2 Normative references.....	6
3 Definitions .....	6
4 Principles of HAZOP .....	7
4.1 Overview .....	7
4.2 Principles of examination.....	10
4.3 Design representation.....	11
4.3.1 General.....	11
4.3.2 Design requirements and design intent .....	12
5 Applications of HAZOP .....	12
5.1 General .....	12
5.2 Relation to other analysis tools .....	13
5.3 HAZOP limitations .....	13
5.4 Hazard identification studies during different system life cycle phases.....	14
5.4.1 Concept and definition phase.....	14
5.4.2 Design and development phase .....	14
5.4.3 Manufacturing and installation phase .....	14
5.4.4 Operation and maintenance phase.....	14
5.4.5 Decommissioning or disposal phase .....	15
6 The HAZOP study procedure .....	15
6.1 Initiation of the study .....	15
6.2 Definition of scope and objectives of the study .....	15
6.2.1 Scope of the study .....	15
6.2.2 Objectives of the study.....	15
6.3 Roles and responsibilities .....	16
6.4 Preparatory work .....	17
6.4.1 General.....	17
6.4.2 Design description .....	18
6.4.3 Guide words and deviations .....	18
6.5 The examination .....	19
6.6 Documentation .....	23
6.6.1 General.....	23
6.6.2 Styles of recording .....	23
6.6.3 Output of the study .....	23
6.6.4 Reporting requirements.....	24
6.6.5 Signing off the documentation.....	24
6.7 Follow-up and responsibility.....	24
7 Audit.....	25

Annex A (informative) Methods of reporting.....	26
A.1 Reporting options .....	26
A.2 HAZOP worksheet .....	26
A.3 HAZOP study report.....	27
Annex B (informative) Examples of HAZOP .....	28
B.1 Introductory example .....	28
B.2 Procedures .....	34
B.3 Automatic train protection system .....	38
B.3.1 The application .....	38
B.4 Example involving emergency planning .....	41
B.5 Piezo valve control system .....	46
B.6 Oil vaporizer .....	52
Bibliography.....	57
Table 1 – Basic guide words and their generic meanings .....	10
Table 2 – Guide words relating to clock time and order or sequence .....	11
Table 3 – Examples of deviations and their associated guide words .....	19
Table B.1 – Example HAZOP worksheet for introductory example .....	30
Table B.2 – Example HAZOP worksheet for procedures example .....	35
Table B.3 – Example HAZOP worksheet for automatic train protection system .....	39
Table B.4 – Example HAZOP worksheet for emergency planning .....	42
Table B.5 – Example HAZOP worksheet for piezo valve control system .....	49
Table B.6 – Example HAZOP worksheet for oil vaporizer .....	53
Figure 1 – The HAZOP study procedure.....	9
Figure 2a – Flow chart of the HAZOP examination procedure – Element first sequence .....	21
Figure 2b – Flow chart of the HAZOP examination procedure – Guide word first sequence .....	22
Figure B.1 – Simple flow sheet.....	29
Figure B.2 – Train-carried ATP equipment.....	38
Figure B.3 – Piezo valve control system.....	47
Figure B.4 – Oil vaporizer .....	52

## INTERNATIONAL ELECTROTECHNICAL COMMISSION

HAZARD AND OPERABILITY STUDIES (HAZOP STUDIES) –  
APPLICATION GUIDE

## FOREWORD

- 1) The IEC (International Electrotechnical Commission) is a worldwide organization for standardization comprising all national electrotechnical committees (IEC National Committees). The object of the IEC is to promote international co-operation on all questions concerning standardization in the electrical and electronic fields. To this end and in addition to other activities, the IEC publishes International Standards. Their preparation is entrusted to technical committees; any IEC National Committee interested in the subject dealt with may participate in this preparatory work. International, governmental and non-governmental organizations liaising with the IEC also participate in this preparation. The IEC collaborates closely with the International Organization for Standardization (ISO) in accordance with conditions determined by agreement between the two organizations.
- 2) The formal decisions or agreements of the IEC on technical matters express, as nearly as possible, an international consensus of opinion on the relevant subjects since each technical committee has representation from all interested National Committees.
- 3) The documents produced have the form of recommendations for international use and are published in the form of standards, technical specifications, technical reports or guides and they are accepted by the National Committees in that sense.
- 4) In order to promote international unification, IEC National Committees undertake to apply IEC International Standards transparently to the maximum extent possible in their national and regional standards. Any divergence between the IEC Standard and the corresponding national or regional standard shall be clearly indicated in the latter.
- 5) The IEC provides no marking procedure to indicate its approval and cannot be rendered responsible for any equipment declared to be in conformity with one of its standards.
- 6) Attention is drawn to the possibility that some of the elements of this International Standard may be the subject of patent rights. The IEC shall not be held responsible for identifying any or all such patent rights.

International Standard IEC 61882 has been prepared by IEC technical committee 56: Dependability.

The text of this standard is based on the following documents:

FDIS	Report on voting
56/731/FDIS	56/733/RVD

Full information on the voting for the approval of this standard can be found in the report on voting indicated in the above table.

This publication has been drafted in accordance with the ISO/IEC Directives, Part 3.

Annexes A and B are for information only.

The committee has decided that the contents of this publication will remain unchanged until 2005. At this date, the publication will be

- reconfirmed;
- withdrawn;
- replaced by a revised edition, or
- amended.

## INTRODUCTION

The purpose of this standard is to describe the principles and procedures of Hazard and Operability (HAZOP) Studies. HAZOP is a structured and systematic technique for examining a defined system, with the objective of:

- identifying potential hazards in the system. The hazards involved may include both those essentially relevant only to the immediate area of the system and those with a much wider sphere of influence, e.g. some environmental hazards;
- identifying potential operability problems with the system and in particular identifying causes of operational disturbances and production deviations likely to lead to non-conforming products.

An important benefit of HAZOP studies is that the resulting knowledge, obtained by identifying potential hazards and operability problems in a structured and systematic manner, is of great assistance in determining appropriate remedial measures.

A characteristic feature of a HAZOP study is the "examination session" during which a multi-disciplinary team under the guidance of a study leader systematically examines all relevant parts of a design or system. It identifies deviations from the system design intent utilizing a core set of guide words. The technique aims to stimulate the imagination of participants in a systematic way to identify hazards and operability problems. HAZOP should be seen as an enhancement to sound design using experience-based approaches such as codes of practice rather than a substitute for such approaches.

There are many different tools and techniques available for the identification of potential hazards and operability problems, ranging from Checklists, Fault Modes and Effects Analysis (FMEA), Fault Tree Analysis (FTA) to HAZOP. Some techniques, such as Checklists and What-If/analysis, can be used early in the system life cycle when little information is available, or in later phases if a less detailed analysis is needed. HAZOP studies require more details regarding the systems under consideration, but produce more comprehensive information on hazards and errors in the system design.

The term HAZOP has been often associated, in a generic sense, with some other hazard identification techniques (e.g. checklist HAZOP, HAZOP 1 or 2, knowledge-based HAZOP). The use of the term with such techniques is considered to be inappropriate and is specifically excluded from this document.

Before commencing a HAZOP study, it should be confirmed that it is the most appropriate technique (either individually or in combination with other techniques) for the task in hand. In making this judgement, consideration should be given to the purpose of the study, the possible severity of any consequences, the appropriate level of detail, the availability of relevant data and resources.

This standard has been developed to provide guidance across many industries and types of system. There are more specific standards and guides within some industries, notably the process industries where the technique originated, which establish preferred methods of application for these industries. For details see the bibliography at the end of this text.

## HAZARD AND OPERABILITY STUDIES (HAZOP STUDIES) – APPLICATION GUIDE

### 1 Scope

This International Standard provides a guide for HAZOP studies of systems utilizing the specific set of guide words defined in this document. It also gives guidance on application of the technique and on the HAZOP study procedure, including definition, preparation, examination sessions and resulting documentation and follow-up.

Documentation, as well as a broad set of examples encompassing various industries, illustrating HAZOP examination is also provided.

### 2 Normative references

The following normative documents contain provisions which, through reference in this text, constitute provisions of this International Standard. For dated references, subsequent amendments to, or revisions of, any of these publications do not apply. However, parties to agreements based on this International Standard are encouraged to investigate the possibility of applying the most recent editions of the normative documents indicated below. For undated references, the latest edition of the normative document referred to applies. Members of IEC and ISO maintain registers of currently valid International Standards.

IEC 60300-3-9, *Dependability management – Part 3: Application guide – Section 9: Risk analysis of technological systems*

IEC 60812, *Analysis techniques for system reliability – Procedure for failure mode and effects analysis (FMEA)*

IEC 61025, *Fault tree analysis (FTA)*

IEC 61160, *Formal design review*

### 3 Definitions

For the purposes of this International Standard, definitions contained in IEC 60050(191) as well as the following terms and definitions apply:

#### 3.1

##### **characteristic**

qualitative or quantitative property of an element

NOTE Examples of characteristics are pressure, temperature, voltage.

#### 3.2

##### **design intent**

designer's desired, or specified range of behaviour for elements and characteristics



**3.3****deviation**

departure from the design intent

**3.4****element**

constituent of a part which serves to identify the part's essential features

NOTE The choice of elements may depend upon the particular application, but elements can include features such as the material involved, the activity being carried out, the equipment employed, etc. Material should be considered in a general sense and includes data, software, etc.

**3.5****guide word**

word or phrase which expresses and defines a specific type of deviation from an element's design intent

**3.6****harm**

physical injury or damage to the health of people or damage to property or the environment

**3.7****hazard**

potential source of harm

**3.8****part**

section of the system which is the subject of immediate study

NOTE A part may be physical (e.g. hardware) or logical (e.g. step in an operational sequence).

**3.9****risk**

combination of the probability of occurrence of harm and the severity of that harm

**4 Principles of HAZOP****4.1 Overview**

A HAZOP study is a detailed hazard and operability problem identification process, carried out by a team. HAZOP deals with the identification of potential deviations from the design intent, examination of their possible causes and assessment of their consequences.

Key features of HAZOP examination include the following.

- The examination is a creative process. The examination proceeds by systematically using a series of guide words to identify potential deviations from the design intent and employing these deviations as "triggering devices" to stimulate team members to envisage how the deviation might occur and what might be the consequences.
- The examination is carried out under the guidance of a trained and experienced study leader, who has to ensure comprehensive coverage of the system under study, using logical, analytical thinking. The study leader is preferably assisted by a recorder who records identified hazards and/or operational disturbances for further evaluation and resolution.

- The examination relies on specialists from various disciplines with appropriate skills and experience who display intuition and good judgement.
- The examination should be carried out in a climate of positive thinking and frank discussion. When a problem is identified, it is recorded for subsequent assessment and resolution.
- Solutions to identified problems are not a primary objective of the HAZOP examination, but if made they are recorded for consideration by those responsible for the design.

HAZOP studies consist of four basic sequential steps, shown in Figure 1.

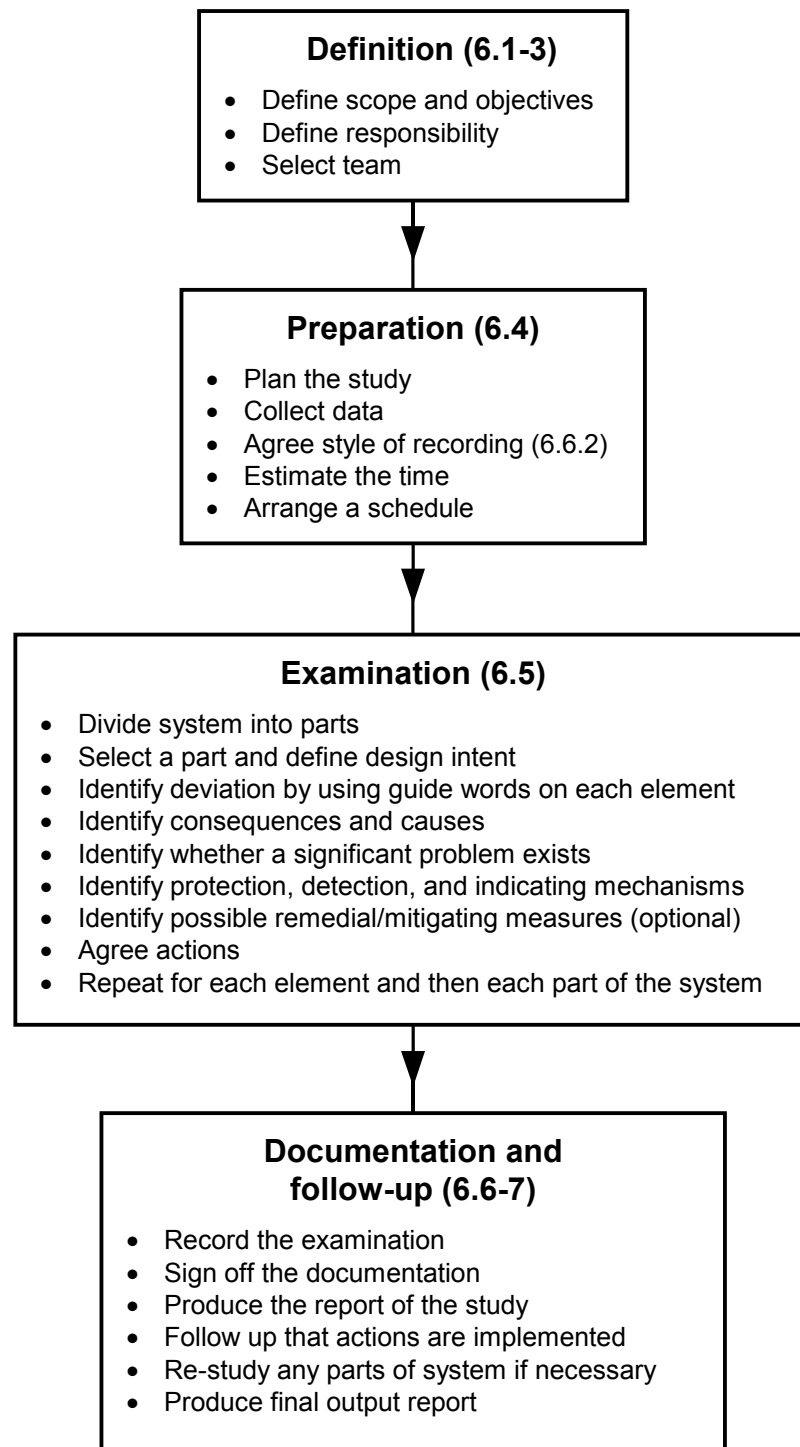

IEC 450/01

Figure 1 – The HAZOP study procedure

## 4.2 Principles of examination

The basis of HAZOP is a “guide word examination” which is a deliberate search for deviations from the design intent. To facilitate the examination, a system is divided into parts in such a way that the design intent for each part can be adequately defined. The size of the part chosen is likely to depend on the complexity of the system and the severity of the hazard. In complex systems or those which present a high hazard the parts are likely to be small. In simple systems or those which present low hazards, the use of larger parts will expedite the study. The design intent for a given part of a system is expressed in terms of elements which convey the essential features of the part and which represent natural divisions of the part. The selection of elements to be examined is to some extent a subjective decision in that there may be several combinations which will achieve the required purpose and the choice may also depend upon the particular application. Elements may be discrete steps or stages in a procedure, individual signals and equipment items in a control system, equipment or components in a process or electronic system, etc.

In some cases it may be helpful to express the function of a part in terms of:

- the input material taken from a source;
- an activity which is performed on that material;
- a product which is taken to a destination.

Thus the design intent will contain the following elements: materials, activities, sources and destinations which can be viewed as elements of the part.

Elements can often be usefully defined further in terms of characteristics which can be either quantitative or qualitative. For example, in a chemical system, the element “material” may be defined further in terms of characteristics such as temperature, pressure and composition. For the activity “transport”, characteristics such as the rate of movement or the number of passengers may be relevant. For computer-based systems, information rather than material is likely to be the subject of each part.

The HAZOP team examines each element (and characteristic, where relevant) for deviation from the design intent which can lead to undesirable consequences. The identification of deviations from the design intent is achieved by a questioning process using predetermined “guide words”. The role of the guide word is to stimulate imaginative thinking, to focus the study and elicit ideas and discussion, thereby maximizing the chances of study completeness. Basic guide words and their meanings are given in Table 1.

**Table 1 – Basic guide words and their generic meanings**

Guide word	Meaning
NO OR NOT	Complete negation of the design intent
MORE	Quantitative increase
LESS	Quantitative decrease
AS WELL AS	Qualitative modification/increase
PART OF	Qualitative modification/decrease
REVERSE	Logical opposite of the design intent
OTHER THAN	Complete substitution

Additional guide words relating to clock time and order or sequence are given in Table 2.

**Table 2 – Guide words relating to clock time and order or sequence**

Guide word	Meaning
EARLY	Relative to the clock time
LATE	Relative to the clock time
BEFORE	Relating to order or sequence
AFTER	Relating to order or sequence

There are a number of interpretations of the above guide words. Additional guide words may be used to facilitate identification of deviation. Such guide words may be used provided they are identified before the examination commences. Having selected a part for examination, the design intent of that part is broken into separate elements. Each relevant guide word is then applied to each element, thus a thorough search for deviations is carried out in a systematic manner. Having applied a guide word, possible causes and consequences of a given deviation are examined and mechanisms for detection or indication of failures may also be investigated. The results of the examination are recorded to an agreed format (see 6.6.2).

Guide word/element associations may be regarded as a matrix, with the guide words defining the rows and the elements defining the columns. Within each cell of the matrix thus formed will be a specific guide word/element combination. To achieve a comprehensive hazard identification, it is necessary that the elements and their associated characteristics cover all relevant aspects of the design intent and guide words cover all deviations. Not all combinations will give credible deviations, so the matrix may have several empty spaces when all guide word/element combinations are considered.

There are two possible sequences in which the cells of the matrix can be examined, namely column by column, i.e. *element first*, or row by row, i.e. *guide word first*. The details of examination are outlined in 6.5 and both sequences of examination are illustrated in Figures 2a and 2b. In principle the results of the examination should be the same.

### 4.3 Design representation

#### 4.3.1 General

An accurate and complete design representation of the system under study is a prerequisite to the examination task. A design representation is a descriptive model of the system adequately describing the system under study, its parts and elements, and identifying their characteristics. The representation may be of the physical design or of the logical design and it should be made clear what is represented.

The design representation should convey the system function of each part and element in a qualitative or quantitative manner. It should also describe the interactions of the system with other systems, with its operator/user and possibly with the environment. The conformance of elements or characteristics to their design intent determines the correctness of operations and in some cases the safety of the system.

The representation of the system consists of two basic parts:

- the system requirements;
- a physical and/or logical description of the design.

The resulting value of a HAZOP study depends on the completeness, adequacy and accuracy of the design representation including the design intent. Care should be taken, therefore, in preparation of the information package. If HAZOP is being conducted in the operational or disposal phase, care should be taken to ensure that any modifications are reflected in the design representation. Before starting the examination, the team should review this information package, and if necessary have it revised.

#### **4.3.2 Design requirements and design intent**

The design requirements consist of qualitative and quantitative requirements which the system has to satisfy, and provide the basis for development of system design and design intent. All reasonable use and misuse conditions which are expected by the user should be identified. Both the design requirements and resulting design intent have to meet customer expectations.

On the basis of system requirements a designer develops the system design, i.e. a system configuration is arrived at, and specific functions are assigned to subsystems and components. Components are specified and selected. The designer should not only consider what the equipment should do, but also ensure that it will not fail under any unusual set of conditions, or that it will not wear out during the specified lifetime. Undesirable behaviour or features should also be identified so they can be designed out, or their effects minimized by appropriate design. The above information provides the basis for identifying the design intent for the parts to be examined.

The "design intent" forms a baseline for the examination and should be correct and complete, as far as possible. The verification of design intent (see IEC 61160), is outside of the scope of the HAZOP study, but the study leader should ascertain that it is correct and complete to allow the study to proceed. In general most documented design intents are limited to basic system functions and parameters under normal operating conditions. However provisions for abnormal operating conditions and undesirable activities which may occur (e.g. severe vibrations, water hammer in pipes, voltage surges which may lead to failure) are rarely mentioned, but should be identified and considered during the examination. Also deterioration mechanisms such as ageing, corrosion and erosion and other mechanisms which cause deterioration in material properties are not specifically stated. However they have to be identified and considered in a study using appropriate guide words.

Expected life, reliability, maintainability and maintenance support should also be identified and considered together with hazards which may be encountered during maintenance activities, provided they are included in the scope of the HAZOP study.

## **5 Applications of HAZOP**

### **5.1 General**

Originally HAZOP was a technique developed for systems involving the treatment of a fluid medium or other material flow in the process industries. However its area of application has steadily widened in recent years and for example includes usage for:

- software applications including programmable electronic systems;

- systems involving the movement of people by transport modes such as road and rail;
- examining different operating sequences and procedures;
- assessing administrative procedures in different industries;
- assessing specific systems, e.g. medical devices.

HAZOP is particularly useful for identifying weaknesses in systems (existing or proposed) involving the flow of materials, people or data, or a number of events or activities in a planned sequence or the procedures controlling such a sequence. As well as being a valuable tool in the design and development of new systems, HAZOP may also be profitably employed to examine hazards and potential problems associated with different operating states of a given system, e.g. start-up, standby, normal operation, normal shutdown, emergency shutdown. It can also be employed for batch and unsteady-state processes and sequences as well as for continuous ones. HAZOP may be viewed as an integral part of the overall process of value engineering and risk management.

## 5.2 Relation to other analysis tools

HAZOP may be used in conjunction with other dependability analysis methods such as Failure mode and effects analysis (see IEC 60812) and Fault tree analysis (see IEC 61025). Such combinations may be utilized in situations when:

- the HAZOP analysis clearly indicates that the performance of a particular item of equipment is critical and needs to be examined in considerable depth; the HAZOP may then be usefully complemented by an FMEA of that item of equipment;
- having examined single element/single characteristic deviations by HAZOP, it is decided to assess the effect of multiple deviations using FTA, or to quantify the likelihood of the failures, again using FTA.

HAZOP is essentially a system-centred approach, as opposed to FMEA which is component-centred. FMEA starts with a possible component failure and then proceeds to investigate the consequences of this failure on the system as a whole. Thus the investigation is unidirectional, from cause to consequence. This is different in concept from a HAZOP study which is concerned with identifying possible deviations from the design intent and then proceeds in two directions, one to find the potential causes of the deviation and the other to deduce its consequences.

## 5.3 HAZOP limitations

Whilst HAZOP studies have proved to be extremely useful in a variety of different industries, the technique has limitations that should be taken into account when considering a potential application.

- HAZOP is a hazard identification technique which considers system parts individually and methodically examines the effects of deviations on each part. Sometimes a serious hazard will involve the interaction between a number of parts of the system. In these cases the hazard may need to be studied in more detail using techniques such as event tree and fault tree analyses.
- As with any technique for the identification of hazards or operability problems, there can be no guarantee that all hazards or operability problems will be identified in a HAZOP study. The study of a complex system should not, therefore, depend entirely upon HAZOP. It should be used in conjunction with other suitable techniques. It is essential that other relevant studies are co-ordinated within an effective overall safety management system.

- Many systems are highly inter-linked, and a deviation at one of them may have a cause elsewhere. Adequate local mitigating action may not address the real cause and still result in a subsequent accident. Many accidents have occurred because small local modifications had unforeseen knock-on effects elsewhere. Whilst this problem can be overcome by carrying forward the implications of deviations from one part to another, in practice this is frequently not done.
- The success of a HAZOP study depends greatly on the ability and experience of the study leader and the knowledge, experience and interaction between team members.
- HAZOP only considers parts that appear on the design representation. Activities and operations which do not appear on the representation are not considered.

#### **5.4 Hazard identification studies during different system life cycle phases**

HAZOP studies are one of the structured hazard analysis tools most suitable in the later stages of detailed design for examining operating facilities, and when changes to existing facilities are made. Application of HAZOP and other methods of analysis during the various lifecycle phases of a system is described in more detail below.

##### **5.4.1 Concept and definition phase**

In this phase of a system's life cycle, the design concept and major system parts are decided but the detailed design and documentation required to conduct the HAZOP do not exist. However, it is necessary to identify major hazards at this time, to allow them to be considered in the design process and to facilitate future HAZOP studies. To carry out these studies, other basic methods should be used. (For descriptions of these methods, see IEC 60300-3-9.)

##### **5.4.2 Design and development phase**

During this phase of a life cycle, detailed design is developed, methods of operation are decided upon and documentation is prepared. The design reaches maturity and is frozen. The best time to carry out a HAZOP study is just before the design is frozen. At this stage the design is sufficiently detailed to allow the questioning mechanism of a HAZOP to obtain meaningful answers. It is important to have a system that will assess the implications of any changes made after the HAZOP has been carried out. This system should be maintained throughout the life of the system.

##### **5.4.3 Manufacturing and installation phase**

It is advisable to carry out a study before the system is started up, if commissioning and operation of the system can be hazardous and proper operating sequences and instructions are critical, or when there has been a substantial change of intent in a late stage. Additional data such as commissioning and operating instructions should be available at this time. In addition, the study should also review all actions raised during earlier studies to ensure that these have been resolved.

##### **5.4.4 Operation and maintenance phase**

The application of HAZOP should be considered before implementing any changes that could effect the safety or operability of a system or have environmental effects. A procedure should also be put in place for periodic reviews of a system to counteract the effects of "creeping change". It is important that the design documentation and operating instructions used in a study are up to date.



#### 5.4.5 Decommissioning or disposal phase

A study of this phase may be required, due to hazards that may not be present during normal operation. If records from previous studies exist, this study can be carried out expeditiously. Records should be kept throughout the life of the system in order to ensure that the decommissioning issues can be dealt with expeditiously.

## 6 The HAZOP study procedure

### 6.1 Initiation of the study

The study is generally initiated by a person with responsibility for the project, who in this guide is called "project manager". The project manager should determine when a study is required, appoint a study leader and provide the necessary resources to carry it out. The need for such a study will often have been identified during normal project planning, due to legal requirements or company policy. With the assistance of the study leader, the project manager should define the scope and objectives of the study. Prior to the start of a study, someone with an appropriate level of authority should be assigned responsibility for ensuring that actions/recommendations from the study are implemented.

### 6.2 Definition of scope and objectives of the study

The objectives and scope of a study are inter-dependent, and should be developed together. Both should be clearly stated, to ensure that:

- the system boundaries, and its interfaces with other systems and the environment are clearly defined;
- the study team is focused, and does not stray into areas irrelevant to the objective.

#### 6.2.1 Scope of the study

This will depend upon a number of factors, including:

- the physical boundaries of the system;
- the number and level of detail of the design representations available;
- the scope of any previous studies, whether HAZOP or other relevant analyses, carried out on the system;
- any regulatory requirements which are applicable to the system.

#### 6.2.2 Objectives of the study

In general, HAZOP studies seek to identify all hazards and operating problems regardless of type or consequences. Focusing a HAZOP study strictly on identifying hazards will enable the study to be completed in shorter time and with less effort.

The following factors should be considered when defining objectives of the study:

- the purpose for which the results of the study will be used;
- the phase of the life cycle at which the study is to be carried out (for details see 5.4);
- persons or property that may be at risk, e.g. staff, the general public, the environment, the system;

- operability problems, including effects on product quality;
- the standards required of the system, both in terms of safety and operational performance.

### 6.3 Roles and responsibilities

The role and responsibilities of a HAZOP team should be clearly defined by the project manager and agreed with the HAZOP study leader at the outset of the study. The study leader should review the design to determine what information is available and what skills are required from the study team members. A programme of activities should be developed, which reflects the milestones of the project, to enable any recommendations to be carried out in a timely fashion.

It is the study leader's responsibility to ensure that an appropriate communication system is set up and is used for transferring the result of the HAZOP study. It is the responsibility of the project manager to ensure that the results of the study are followed up and decisions regarding implementation made by the design team are properly documented.

The project manager and the study leader should agree whether the HAZOP team activity is to be confined to identification of hazards and problem areas (which are then referred back to the project manager and design team for resolution) or whether they are also to suggest possible remedial/mitigating measures. In the latter case there also needs to be agreement as to the responsibility and mechanism for selecting preferred remedial/mitigating measures and securing appropriate authorization for action to be taken.

A HAZOP study is a team effort, with each team member being chosen for a defined role. The team should be as small as possible consistent with the relevant technical and operating skills and experience being available. This will generally involve at least four persons and rarely more than seven. The larger the team, the slower the process. Where a system has been designed by a contractor, the HAZOP team should contain personnel from both the contractor and the client.

Recommended roles for team members are as follows:

- Study leader: not closely associated with the design team and the project. Trained and experienced in leading HAZOP studies. Responsible for communications between project management and the HAZOP team. Plans the study. Agrees study team composition. Ensures the study team is supplied with a design representation package. Suggests guide words and guide word – element/characteristic interpretations to be used in the study. Conducts the study. Ensures documentation of the results.
- Recorder: documents proceedings of the meetings. Documents the hazards and problem areas identified, recommendations made and any actions for follow-up. Assists the study leader in planning and administrative duties. In some cases, the study leader may carry out this role.
- Designer: explains the design and its representation. Explains how a defined deviation can occur and the corresponding system response.
- User: explains the operational context within which the element under study will operate, the operational consequences of a deviation and the extent to which deviations may be hazardous.
- Specialists: provide expertise relevant to the system and the study. May be called upon for limited participation with the role revolving amongst different individuals.
- Maintainer: maintenance staff representative (when required).

The viewpoint of the designer and user are always required for the study. However depending on the particular phase of the life cycle in which the study is carried out, the type of specialists most appropriate to the study may vary.

All team members should have sufficient knowledge of the HAZOP technique to enable them to participate effectively in the study, or suitable introduction should be provided.

## 6.4 Preparatory work

### 6.4.1 General

The study leader is responsible for the following preparatory work:

- a) obtaining the information;
- b) converting the information into a suitable format;
- c) planning the sequence of the meetings;
- d) arranging the necessary meetings.

In addition, the study leader may arrange for a search to be made of databases, etc. to identify incidents which have occurred with the same or similar technologies.

The study leader is responsible for ensuring that an adequate design representation is available. If the design representation is flawed or incomplete, it should be corrected before the study begins. In the planning stage of a study, the parts, elements and their characteristics should be identified on the design representation by a person familiar with the design.

The study leader is responsible for the preparation of a study plan that should contain the following:

- objective and scope of the study;
- a list of participating members;
- technical details:
  - a design representation divided into parts and elements with defined design intent and for each element a list of components, materials and activities and their characteristics;
  - a list of proposed guide words to be used, and the interpretation of guide word – element/characteristic combinations as outlined in 6.4.3;
- a list of appropriate references;
- administrative arrangements, schedule of meetings, including their dates and times and locations;
- form of recording required (see annex A);
- templates that may be used in the study.

Adequate room facilities and visual and recording aids should be provided to facilitate efficient conduct of the meetings.

The briefing package consisting of the study plan and necessary references should be sent to the study team members in advance of the first meeting to allow them to familiarize themselves with its content. A physical review of the system is desirable.

The success of the HAZOP study strongly depends on the alertness and concentration of the team members and it is therefore important that the sessions are of limited duration and that there are appropriate intervals between sessions. How these requirements are achieved is ultimately the responsibility of the study leader.

#### 6.4.2 Design description

Typically a design description may consist of some of the following documentation which should be clearly and uniquely identified, approved and dated:

- a) for all systems:
  - design requirements and descriptions, flow sheets, functional block diagrams, control diagrams, electrical circuit diagrams, engineering data sheets, arrangement drawings, utilities specifications, operating and maintenance requirements;
- b) for process flow systems:
  - piping and instrumentation diagrams, material specifications and standards equipment, piping and system layout;
- c) for programmable electronic systems:
  - data flow diagrams, object-oriented design diagrams, state transition diagrams, timing diagrams, logic diagrams.

In addition, the following information should be provided:

- the boundaries of the object of the study and the interfaces at the borders;
- environmental conditions in which the system will operate;
- operating and maintenance personnel qualifications, skills and experience;
- procedures and/or operating instructions;
- operational and maintenance experience and known hazards with similar systems.

#### 6.4.3 Guide words and deviations

In the planning stage of a HAZOP study, the study leader should propose an initial list of guide words to be used. The study leader should test the proposed guide words against the system and confirm their adequacy. The choice of guide words should be considered carefully, as a guide word which is too specific may limit ideas and discussion, and one which is too general may not focus the HAZOP study efficiently. Some examples of different types of deviation and their associated guide words are given in Table 3.

Table 3 – Examples of deviations and their associated guide words

Deviation type	Guide word	Example interpretation for process industry	Example interpretation for a Programmable Electronic System, PES
Negative	NO	No part of the intention is achieved, e.g. no flow	No data or control signal passed
Quantitative modification	MORE	A quantitative increase, e.g. higher temperature	Data is passed at a higher rate than intended
	LESS	A quantitative decrease e.g. lower temperature	Data is passed at a lower rate than intended
Qualitative modification	AS WELL AS	Impurities present Simultaneous execution of another operation/step	Some additional or spurious signal is present
	PART OF	Only some of the intention is achieved, i.e. only part of an intended fluid transfer takes place	The data or control signals are incomplete
Substitution	REVERSE	Covers reverse flow in pipes and reverse chemical reactions	Normally not relevant
	OTHER THAN	A result other than the original intention is achieved, i.e. transfer of wrong material	The data or control signals are incorrect
Time	EARLY	Something happens early relative to clock time, e.g. cooling or filtration	The signals arrive too early with reference to clock time
	LATE	Something happens late relative to clock time, e.g. cooling or filtration	The signals arrive too late with reference to clock time
Order or sequence	BEFORE	Something happens too early in a sequence, e.g. mixing or heating	The signals arrive earlier than intended within a sequence
	AFTER	Something happens too late in a sequence, e.g. mixing or heating	The signals arrive later than intended within a sequence

Guide word – element/characteristic combinations may be interpreted differently in studies of different systems, at different phases of the system life cycle, and when applied to different design representations. Some of the combinations may not have meaningful interpretations for a given study and should be disregarded. The interpretation of all guide word – element/characteristic combinations should be defined and documented. If a given combination has more than one sensible interpretation in the context of the design, all interpretations should be listed. On the other hand, it may also be found that the same interpretation is derived from different combinations. When this occurs, appropriate cross references should be made.

### 6.5 The examination

The examination sessions should be structured, with the study leader leading the discussion following the study plan. At the start of a HAZOP study meeting the study leader or a team member who is familiar with the process to be examined and its problems should

- outline the study plan, to ensure that the members are familiar with the system and objectives and scope of the study;

- outline the design representation and explain the proposed elements and guide words to be used;
- review the known hazards and operational problems and potential areas of concern.

The analysis should follow the flow or sequence related to the subject of the analysis, tracing inputs to outputs in a logical sequence. Hazard identification techniques such as HAZOP derive their power from a disciplined step by step examination process. There are two possible sequences of examination: "Element first" and "Guide word first", as shown in Figures 2a and 2b respectively. The element first sequence is described below.

- a) The study leader starts by selecting a part of the design representation as a starting point and marking it. The design intent of the part is then explained and the relevant elements and any characteristics associated with these elements identified.
- b) The study leader chooses one of the elements and agrees with the team whether the guide word should be applied directly to the element itself or to individual characteristics of that element. The study leader identifies which guide word is to be applied first.
- c) The first applicable guide word interpretation is examined in the context of the element or characteristic being studied in order to see if there is a credible deviation from the design intent. If a credible deviation is identified, it is examined for possible causes and consequences. In some applications it is found useful to categorize the deviations either in terms of the potential severity of the consequences or in terms of a relative risk ranking based on the use of a risk matrix. The use of risk matrices is further discussed in IEC 60300-3-9.
- d) The team should identify the presence of protection, detection and indication mechanisms for the deviation, which may be included within the selected part or form a portion of the design intentions of other parts. The presence of such mechanisms should not stop the potential hazard or operability problem being explored or listed or attempts being made to reduce the probability of its occurrence or mitigating its consequences.
- e) The study leader should summarize the results that are documented by the recorder. Where there is a need for additional follow-up work, the name of the person responsible for ensuring that the work is carried out should also be recorded.
- f) The process is then repeated for any other interpretation for that guide word; then for another guide word; then for each characteristic of the element under examination (if analysis at the characteristic level has been agreed for that element); then for each element of the part under study. After a part has been fully examined, it should be marked as completed. The process is repeated until all parts have been analysed.

An alternative method of guide word application to that described above, is to apply the first guide word to each of the elements within a part in turn. When this has been completed, the study proceeds with the next guide word which again is applied to all elements in turn. The process is repeated until all the guide words have been used for all the elements in that particular part before moving on to another part. (See Figure 2b.)

The selection of which sequence to be followed in any particular study should be made by the study leader and his team. It is influenced by the detailed manner in which the HAZOP examination is conducted. Other factors involved in the decision include the nature of the technologies involved, the need for flexibility in the conduct of the examination and, to some extent, the training which the participants have received.

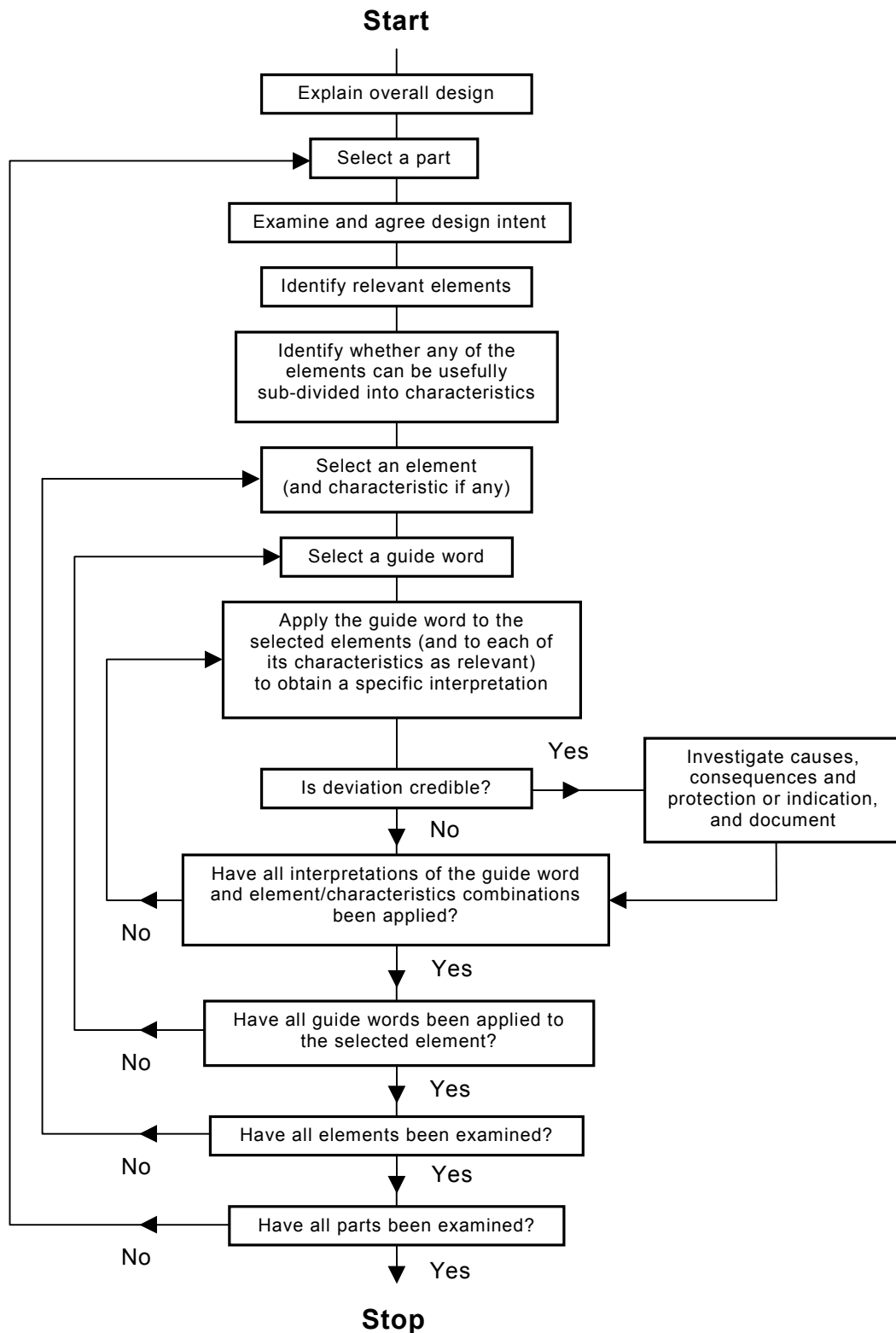

IEC 451/01

Figure 2a – Flow chart of the HAZOP examination procedure – Element first sequence

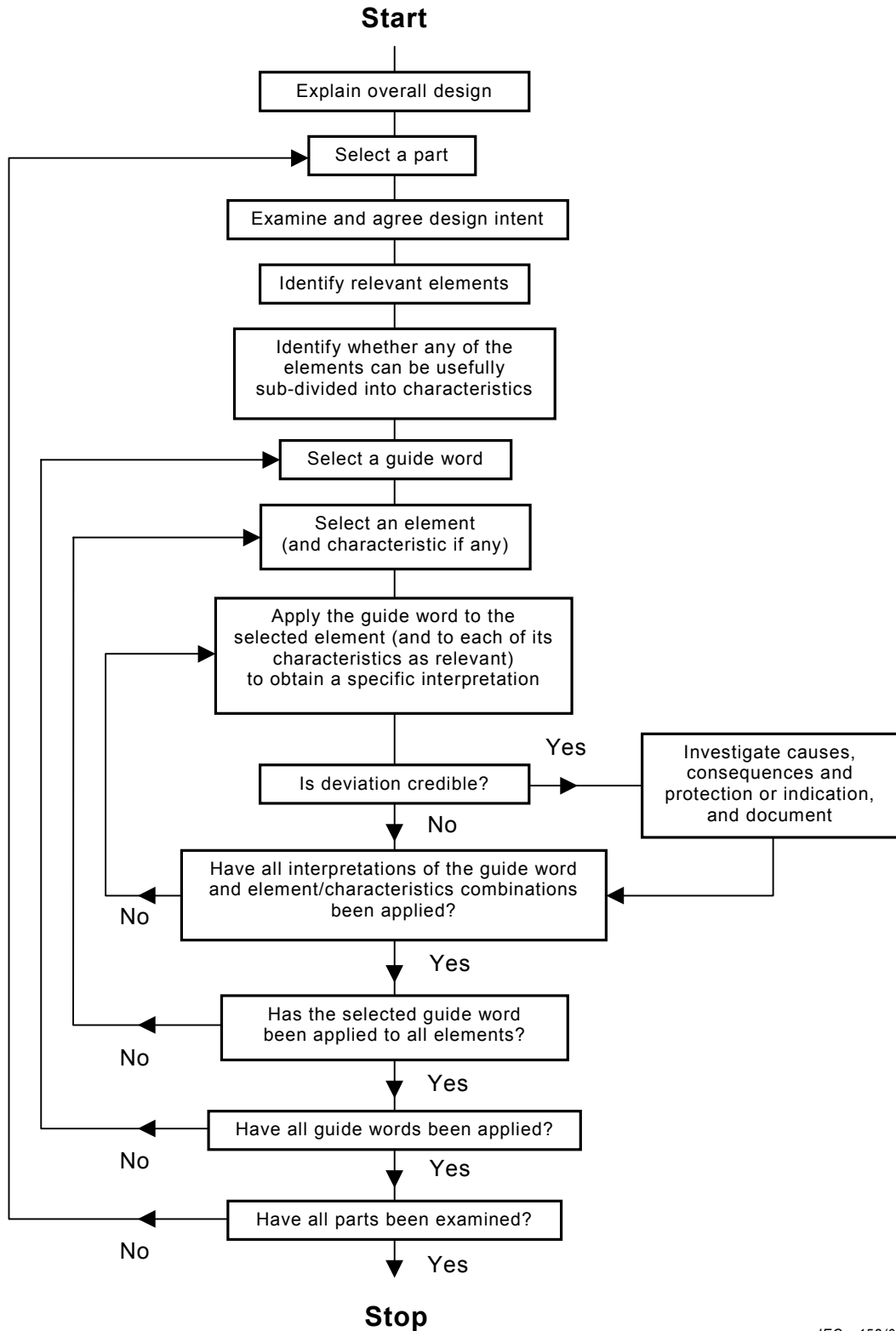

IEC 452/01

Figure 2b – Flow chart of the HAZOP examination procedure – Guide word first sequence



## 6.6 Documentation

### 6.6.1 General

The primary strength of HAZOP is that it presents a systematic, disciplined and documented approach. To achieve full benefits from a HAZOP study, it has to be properly documented and followed up. The study leader is responsible to ensure that suitable records are produced for each meeting. The recorder should have good technical knowledge of the subject being studied, linguistic skills and good ability to listen and pay attention to details. Various methods of reporting are discussed in annex A.

### 6.6.2 Styles of recording

There are two basic styles of HAZOP recording: full, and by exception only. The method of recording should be decided before any sessions take place, and the recorder advised accordingly.

- Full recording involves recording of all results of applying each guide word – element/characteristic combination to every part or element on the design representation. This method, though cumbersome, provides the evidence that the study has been thorough and should satisfy the most stringent audit requirements.
- By exception recording involves recording only the identified hazards and operability problems together with the follow-up actions. Recording by exception results in more easily managed documentation. However, it does not document the thoroughness of the study and is therefore less useful for audit purposes. It can also lead to covering the same ground again at some future study. By exception recording is therefore a minimum requirement and should be used with care.

In deciding the form of reporting to be employed, the following factors should be considered:

- regulatory requirements;
- contractual obligations;
- company corporate policy;
- needs for traceability and auditability;
- the magnitude of the risks posed by the system concerned;
- the time and resources available.

### 6.6.3 Output of the study

The output from a HAZOP study should include the following:

- details of identified hazards and operability problems together with details of any provisions for their detection, and/or mitigation;
- recommendations for any further studies of specific aspects of the design using different techniques, if necessary;
- actions required for addressing uncertainties discovered during the study;
- recommendations for mitigation of the problems identified based on the team's knowledge of the system (if within the scope of the study);
- notes which draw attention to particular points which need to be addressed in the operating and maintenance procedures;
- a list of team members for each session;

- a list of all the parts considered in the analysis together with the rationale where any have been excluded;
- listing of all drawings, specifications, data sheets, reports, etc quoting revision numbers used by the team.

With “by exception” recording, these outputs will normally be contained fairly concisely within the HAZOP worksheets. With full recording, the required outputs may need to be “distilled out” from the overall study worksheets.

#### **6.6.4 Reporting requirements**

The recorded information should conform to the following:

- every hazard and operating problem should be recorded as a separate item;
- all hazards and operating problems together with their causes should be recorded regardless of any protection or alarm mechanism already existing in the system;
- every question raised by the team for study after the meeting, should be recorded, together with name of a person who is responsible to answer it;
- a numbering system should be adopted to ensure that every hazard, operational problem, question, recommendation, etc. is uniquely identifiable;
- the study documentation should be archived for retrieval, as and when required, and referenced in the hazard log for the system (if such exists).

Precisely who should receive a copy of the final report will be largely dictated by internal company policy or by regulatory requirements but should normally include the project manager, the study leader and the person assigned responsibility for ensuring that follow-up actions/recommendations are implemented (see 6.1).

#### **6.6.5 Signing off the documentation**

At the end of the study, the report of the study should be produced and agreed upon by the team. If agreement cannot be reached, reasons should be recorded.

#### **6.7 Follow-up and responsibility**

HAZOP studies are not aimed at redesigning a system. Nor is it usual for the study leader to have the authority to ensure that the study team's recommendations are acted upon.

Before any significant changes resulting from the findings of the HAZOP have been implemented, and once the revised documentation is available, the project manager should consider reconvening the HAZOP team to ensure that no new hazards or operability or maintenance problems have been introduced.

In some cases, as indicated in 6.3, the project manager may authorize the HAZOP team to implement the recommendations and carry out design changes. In this case the HAZOP team may be required to do the following additional work:

- agree on outstanding problems and revise the design or the operating and maintenance procedures;
- verify the revisions and changes and communicate them to the project management and receive their approval;
- conduct further HAZOP studies of revisions, including system interfaces.

## 7 Audit

The program and results of HAZOP studies may be subjected to internal company or regulatory authority audits. Criteria and issues which may be audited should be defined in the company's procedures. These may include: personnel, procedures, preparations, documentation and follow-up. A thorough check of technical aspects should also be included.

## Annex A (informative)

### Methods of reporting

#### A.1 Reporting options

Various recording options are available.

- Manual recording on prepared forms can be perfectly adequate, particularly for small studies, provided that the basic needs for legibility are met.
- Manuscript HAZOP notes may be word-processed after the session, to produce suitable quality of copy for issue.
- A portable computer, with standard word-processing or spread-sheet software, may be used to produce the worksheets during the session.
- Specific PC software codes, of various degrees of sophistication may assist in the recording of the HAZOP results. Using a package that enables the notes of the examination to be displayed (by overhead projector) as they are recorded can provide further savings.

#### A.2 HAZOP worksheet

A worksheet to record the results of examinations and follow-up should be developed or adopted. Regardless of the reporting option adopted, the worksheet should contain the essential features to suit particular requirements, examples of which are given below. The layout of the worksheet will vary depending on whether it is a part of a manual or a computerized reporting program. The manually completed form will normally consist of a header and columns.

The header may contain the following information: project, subject of the study, design intent, part of the system being examined, members of the team, drawing or document being examined, date, page number, etc.

The headings (titles) of the columns may be as follows:

- a) for those completed during the examination:
- 1) reference number;
  - 2) element;
  - 3) guide word;
  - 4) deviation;
  - 5) cause;
  - 6) consequences;
  - 7) action required.

Additional information such as safeguards, severity, comments and risk ranking may also be recorded.

b) for those completed during the follow-up:

- 1) recommended action;
- 2) priority/risk ranking;
- 3) responsibility for action;
- 4) status;
- 5) comments.

NOTE The columns mentioned in points 1, 2 and 3 can also be completed at the meetings themselves.

Computerized reporting allows greater flexibility in layout, better presentation of information and ease of preparation of required reports such as:

- detailed worksheets;
- reports by causes and/or consequences;
- follow-up reports with responsibilities and status.

Customized reporting forms can be developed easily using available word processing systems. In addition, several software packages are available on the market, which simplify the task of recording data and generating reports. Such packages are valuable in aiding the task of the recorder. However, some packages also try to take over the role of the study leader by applying a checklist of guide word – element/characteristic pairs as an alternative to generating deviations by applying guide words directly to elements (and, if necessary, characteristics). Whilst these packages will identify many hazards and produce a print-out which resembles the print-out from a HAZOP they lack the rigour of generating hazards from the “work system” and have limited applicability beyond the area of continuous process units. In particular, the use of computer packages to replace the study leader entirely is to be discouraged. The random application of ad hoc checklists cannot be regarded as a HAZOP as defined in this standard.

### A.3 HAZOP study report

A final report of the HAZOP study should be prepared and contain the following:

- summary;
- conclusions;
- scope and objectives;
- output of the study itemized as outlined in 6.6.3;
- HAZOP worksheets;
- listing of drawings and documentation used in the study;
- references to previous studies, data bases, etc. that were used in the course of the study.

## Annex B (informative)

### Examples of HAZOP

The purpose of the examples contained in this annex is to illustrate how the principles of HAZOP examination, outlined in the guide (particularly in 4.2, 6.4 and 6.5) are applied to a range of applications encompassing various industries and activities. It should be noted however that the examples have been simplified significantly for illustrative purposes and do not purport in any way to reproduce all the detailed technical complexity of real case studies. It should also be noted that only sample outputs are provided.

#### B.1 Introductory example

The purpose of this example is to introduce the reader to the basics of the HAZOP examination method. The example is adopted from one given in the original publication on HAZOP [1]<sup>1</sup>.

Consider a simple process plant, shown in Figure B.1. Materials A and B are continuously transferred by pump from their respective supply tanks to combine and form a product C in the reactor. Suppose that A always has to be in excess of B in the reactor to avoid an explosion hazard. A full design representation would include many other details such as the effect of pressure, reaction and reactant temperature, agitation, reaction time, compatibility of pumps A and B, etc. but for the purposes of this simple illustrative example they will be ignored. The part of the plant being examined is shown in bold.

---

<sup>1</sup> The figures in brackets refer to the Bibliography.

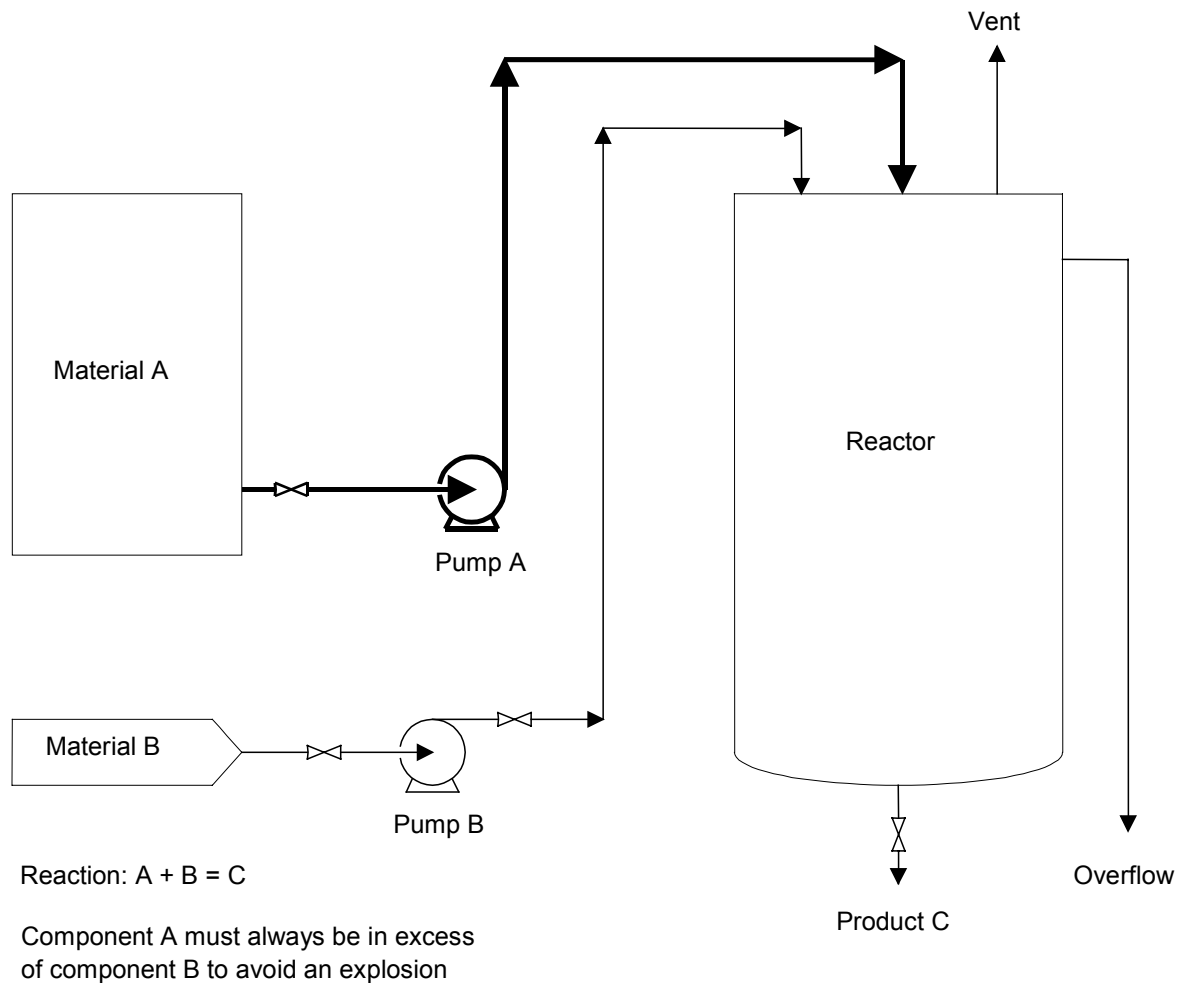

Figure B.1 – Simple flow sheet

The part of the system selected for examination is the line from the supply tank holding A to the reactor, including pump A. The design intent for this part is to continuously transfer material A from the tank to the reactor at a rate greater than the transfer rate of material B. In terms of the elements suggested in 4.2, the design intent is given in the header:

Material	Activity	Source	Destination
A	Transfer (at a rate >B)	Tank for A	Reactor

Each of the guide words indicated in Table 3 (plus any others agreed as appropriate during the preparatory work, see 6.4) is then applied to each of these elements in turn and the results recorded on HAZOP worksheets. Examples of possible HAZOP outputs for the “material” and “activity” elements are indicated in Table B.1, where the “by exception” style of reporting is utilized and only meaningful deviations are recorded. Having examined each of the guide words for each of the elements relevant to this part of the system, another part (say the transfer line for material B) would be selected and the process repeated. Eventually all parts of the system would be examined in this manner and the results recorded.

**Table B.1 – Example HAZOP worksheet for introductory example**

<b>STUDY TITLE:</b> PROCESS EXAMPLE							<b>SHEET:</b> 1 of 4		
<b>Drawing No.:</b>		<b>REV. No.:</b>				<b>DATE:</b> December 17, 1998			
<b>TEAM COMPOSITION:</b>		LB, DH, EK, NE, MG, JK				<b>MEETING DATE:</b> December 15, 1998			
<b>PART CONSIDERED:</b>		Transfer line from supply tank A to reactor							
<b>DESIGN INTENT:</b>		<b>Material:</b> A		<b>Activity:</b> Transfer continuously at a rate greater than B					
		<b>Source:</b> Tank for A		<b>Destination:</b> Reactor					
No.	Guide word	Element	Deviation	Possible causes	Consequences	Safeguards	Comments	Actions required	Action allocated to
1	NO	Material A	No Material A	Supply Tank A is empty	No flow of A into reactor Explosion	None shown	Situation not acceptable	Consider installation on tank A of a low-level alarm plus a low/low-level trip to stop pump B	MG
2	NO	Transfer A (at a rate >B)	No transfer of A takes place	Pump A stopped, line blocked	Explosion	None shown	Situation not acceptable	Measurement of flow rate for material A plus a low flow alarm and a low flow which trips pump B	JK
3	MORE	Material A	More material A: supply tank over full	Filling of tank from tanker when insufficient capacity exists	Tank will overflow into bounded area	None shown	Remark: This would have been identified during examination of the tank	Consider high-level alarm if not previously identified	EK



**Table B.1** (continued)

STUDY TITLE: PROCESS EXAMPLE							SHEET: 2 of 4		
Drawing No.:		REV. No.:				DATE: December 17, 1998			
TEAM COMPOSITION:		LB, DH, EK, NE, MG, JK				MEETING DATE: December 15, 1998			
PART CONSIDERED:		Transfer line from supply tank A to reactor							
DESIGN INTENT:		Material: A		Activity: Transfer continuously at a rate greater than B					
		Source: Tank for A		Destination: Reactor					
No.	Guide word	Element	Deviation	Possible causes	Consequences	Safeguards	Comments	Actions required	Action allocated to
4	MORE	Transfer A	More transfer  Increased flow rate of A	Wrong size impeller  Wrong pump fitted	Possible reduction in yield  Product will contain large excess A	None		Check pump flows and characteristics during commissioning  Revise the commissioning procedure	JK
5	LESS	Material A	Less A	Low level in tank	Inadequate net positive suction head  Possible vortexing and leading to an explosion  Inadequate flow	None	Unacceptable Same as 1	Low-level alarm in tank Same as 1	MG
6	LESS	Transfer A. (at rate >B)	Reduced flow rate of A	Line partially blocked, leakage, pump under-performing, etc.	Explosion	None shown	Not acceptable	Same as 2	JK

**Table B.1** (continued)

<b>STUDY TITLE:</b> PROCESS EXAMPLE							<b>SHEET:</b> 3 of 4		
<b>Drawing No.:</b>		<b>REV. No.:</b>				<b>DATE:</b> December 17, 1998			
<b>TEAM COMPOSITION:</b>		LB, DH, EK, NE, MG, JK				<b>MEETING DATE:</b> December 15, 1998			
<b>PART CONSIDERED:</b>		Transfer line from supply tank A to reactor							
<b>DESIGN INTENT:</b>		<b>Material:</b> A		<b>Activity:</b> Transfer continuously at a rate greater than B					
		<b>Source:</b> Tank for A		<b>Destination:</b> Reactor					
No.	Guide word	Element	Deviation	Possible causes	Consequences	Safeguards	Comments	Actions required	Action allocated to
7	AS WELL AS	Material A	As well as A there is other fluid material also present in the supply tank	Contaminated supply to tank	Not known	Contents of all tankers checked and analysed prior to discharge into tank	Considered acceptable	Check operating procedure	LB
8	AS WELL AS	Transfer A	As well as transferring A, something else happens such as corrosion, erosion, crystallization or decomposition	The potential for each would need to be considered in the light of more specific details					NE
9	AS WELL AS	Destination reactor	As well as to reactor External leaks	Line, valve or gland leaks	Environmental contamination Possible explosion	Use of accepted piping code/standard	Qualified acceptance	Locate flow sensor for trip as close as possible to the reactor	DH

**Table B.1** (continued)

<b>STUDY TITLE:</b> PROCESS EXAMPLE							<b>SHEET:</b> 4 of 4		
<b>Drawing No.:</b>		<b>REV. No.:</b>				<b>DATE:</b> December 17, 1998			
<b>TEAM COMPOSITION:</b>		LB, DH, EK, NE, MG, JK				<b>MEETING DATE:</b> December 15, 1998			
<b>PART CONSIDERED:</b>		Transfer line from supply tank A to reactor							
<b>DESIGN INTENT:</b>		<b>Material:</b> A		<b>Activity:</b> Transfer continuously at a rate greater than B					
		<b>Source:</b> Tank for A		<b>Destination:</b> Reactor					
No.	Guide word	Element	Deviation	Possible causes	Consequences	Safeguards	Comments	Actions required	Action allocated to
10	REVERSE	Transfer A	Reverse direction of flow Material flows from reactor to supply tank	Pressure in reactor higher than pump discharge pressure	Back contamination of supply tank with reaction material	None shown	Position not satisfactory	Consider installing a non-return valve in the line	MG
11	OTHER THAN	Material A	Other than A Material other than A in supply tank	Wrong material in supply tank	Unknown Would depend on material	Tanker contents identity checked and analysed prior to discharge	Position acceptable		
12	OTHER THAN	Destination reactor	External leak Nothing reaches reactor	Line fracture	Environmental contamination and possible explosion	Integrity of piping	Check piping design	Specify that proposed flow trip should have a sufficiently rapid response to prevent an explosion	MG

## B.2 Procedures

Consider a small batch process for the manufacture of a safety critical plastic component. The component has to meet a tight specification in terms both of its material properties and its colour. The processing sequence is as follows:

- a) take 12 kg of powder "A";
- b) place in blender;
- c) take 3 kg of colorant powder "B";
- d) place in blender;
- e) start blender;
- f) mix for 15 min; stop blender;
- g) remove blended mixture into 3 × 5 kg bags;
- h) wash out blender;
- i) add 50 l of resin to mixing vessel;
- j) add 0,5 kg of hardener to mixing vessel;
- k) add 5 kg of mixed powder ("A" and "B");
- l) stir for 1 min;
- m) pour mixture into moulds within 5 min.

A HAZOP study is carried out to examine ways in which below-specification material might be produced. As a procedural sequence, the parts under examination during the HAZOP process are the relevant sequential instructions. Extracts from a HAZOP study of the sequence are given in Table B.2. A "by exception" reporting system has been employed.

**Table B.2 – Example HAZOP worksheet for procedures example**

<b>STUDY TITLE:</b> PROCEDURES								<b>SHEET:</b> 1 of 3	
<b>PROCEDURE TITLE:</b> SMALL SCALE MANUFACTURE OF COMPONENT X						<b>REVISION No.:</b>		<b>DATE:</b>	
<b>TEAM COMPOSITION:</b> BK, JS, LE, PA								<b>MEETING DATE:</b>	
<b>PART CONSIDERED:</b>				<b>INSTRUCTION 1:</b> TAKE 12 kg of POWDER 'A'					
No.	Element	Guide word	Deviation	Possible causes	Consequences	Safeguards	Comments	Actions required	Action allocated to
1	Take powder A	NO	No 'A' taken	Operator error	Final material will not set	Operator should see mass in blender is much too small. Colour would also be far too bright	Complete absence of material 'A' charge not considered credible	None	
2	Take powder A	AS WELL AS	Additional material is added with 'A'	Material 'A' is contaminated with impurities	Colour specification may not be met. Final mix may not set properly	Sample from all deliveries of 'A' are tested prior to use		Check quality assurance procedures at manufacturer's	BK
3	Take powder A	OTHER THAN	Material other than 'A' is taken	Operator uses a bag of wrong material	Mix cannot be used. Financial loss	Only bags of 'A', 'B' and blend to be kept in blender area		Check house-keeping standards on a weekly basis. Consider having uniquely colored bags for each raw material and blended product	BK
4	Take 12 kg	MORE	Too much 'A' taken	Faulty weighing/ Operator error	Colour specification will not be met	Check weighing carried out weekly. Weighing machine serviced every 6 months		JS to emphasize to operators the need for accurate weighing	JS
5	Take 12 kg	LESS	Too little 'A' taken	Faulty weighing/ Operator error	As above	As above		As above	JS

**Table B.2** (continued)

STUDY TITLE: PROCEDURES								SHEET: 2 of 3	
PROCEDURE TITLE: SMALL SCALE MANUFACTURE OF COMPONENT X					REVISION No:			DATE:	
TEAM COMPOSITION: BK, JS, LE, PA								MEETING DATE:	
PART CONSIDERED:				INSTRUCTION 2: PLACE IN BLENDER					
No.	Element	Guide word	Deviation	Possible causes	Consequences	Safeguards	Comments	Actions required	Action allocated to
6	Blender	OTHER THAN	Material 'A' is placed other than in the correct blender	Operator error		There is currently only one blender		Review the position if there are proposals to fit additional blenders	BK
7	Add hardener	NO	No hardener is added	Operator error	Final mix will not set properly Financial loss	Operator has to sign batch sheet confirming hardener has been added. Mold testing of strength of final item		Review error rate to see if additional safeguards are required	BK
8	Add hardener	AS WELL AS	Additional material is added with hardener	Hardener is contaminated with impurities	Final mix may not be usable	Quality assurance guarantees from supplier Sample testing on all deliveries		None	
9	Add hardener	OTHER THAN	Material other than hardener is added		Final mix will not be usable	Physical segregation of different hardeners Operator checks	If proposal to order pre-weighed, bags of hardener is adopted, scope for mix-up is further reduced	Await outcome of hardener. Purchasing enquiry and review	JS

**Table B.2** (continued)

<b>STUDY TITLE:</b> PROCEDURES								<b>SHEET:</b> 3 of 3	
<b>PROCEDURE TITLE:</b> SMALL SCALE MANUFACTURE OF COMPONENT X						<b>REVISION No:</b>		<b>DATE:</b>	
<b>TEAM COMPOSITION:</b> BK, JS, LE, PA								<b>MEETING DATE:</b>	
<b>PART CONSIDERED:</b>				<b>INSTRUCTION 2:</b> PLACE IN BLENDER					
No.	Element	Guide word	Deviation	Possible causes	Consequences	Safeguards	Comments	Actions required	Action allocated to
10	Add 0,5 kg	MORE	Too much hardener is added	Faulty weighing/ Operator error	Component will be too brittle; may fail catastrophically	Weekly check weighing. Weighing machine serviced every 6 months	Safeguards not considered adequate	Investigate possibility of obtaining hardener in pre-weighed 0,5 kg bags. Sample checks on each delivery	JS
11	Add 0,5 kg	LESS	Too little hardener	As above	Final mix will not set properly Financial loss	As above	As above	As above	JS

### B.3 Automatic train protection system

The purpose of this clause is to give a small example of a typical HAZOP study at the System Block Diagram level to illustrate some of the points in this standard. The example will be presented in two sections:

- a brief description of the system and a block diagram;
- sample HAZOP worksheets exploring some of the potential deviations, reported “by exception only” (see Table B.3).

It should be noted that the design used in this example is of a system at a limited level of detail. The design and the sample HAZOP study worksheets are illustrative only and are not taken from a real system. They are included to show the process and are not claimed to be complete.

#### B.3.1 The application

##### B.3.1.1 System purpose

The application concerns train-carried equipment for Automatic Train Protection (ATP). This is a function implemented on many Metro trains and some mainline trains. ATP monitors the speed of the train, compares that speed with the planned safe speed of the train and automatically initiates emergency braking if an overspeed condition is recognized. On all ATP systems there is equipment on both the train and track-side whereby information is transferred from the track-side to the train. There are many different ATP systems in existence, all differing in the detail of how they fulfil the basic requirement.

##### B.3.1.2 System description

On board the train there are one or more antennae which receive signals from the trackside equipment giving information on safe speeds or stopping points. This information goes through some processing before being passed to a Programmable Electronic System (PES). The other major input to the PES is from tachometers or other means of measuring the actual speed of the train. The major output of the PES is a signal to safety relays such as the one controlling the emergency brake. Figure B.2 gives a simple block diagram of this.

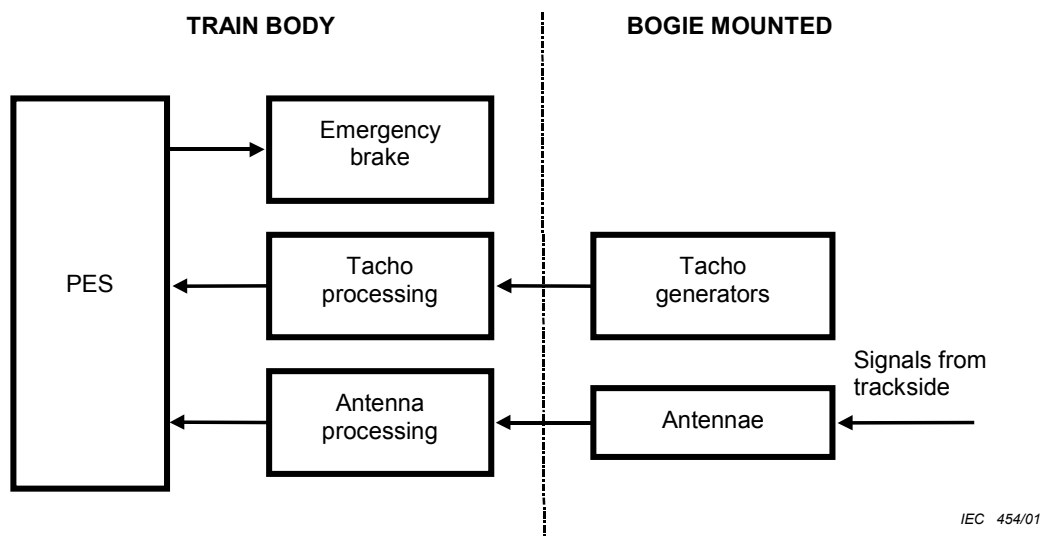

Figure B.2 – Train-carried ATP equipment



**Table B.3 – Example HAZOP worksheet for automatic train protection system**

<b>STUDY TITLE:</b> AUTOMATIC TRAIN PROTECTION SYSTEM									<b>SHEET:</b> 1 of 2	
<b>REFERENCE DRAWING No.:</b> ATP BLOCK DIAGRAM					<b>REVISION No.:</b> 1				<b>DATE:</b>	
<b>TEAM COMPOSITION:</b> DJ, JB, BA									<b>MEETING DATE:</b>	
<b>PART CONSIDERED:</b>				INPUT FROM TRACKSIDE EQUIPMENT						
<b>DESIGN INTENT:</b>				TO PROVIDE SIGNAL TO PES VIA ANTENNAE GIVING INFORMATION ON SAFE SPEEDS AND STOPPING POINTS						
No.	Element	Characteristic	Guide word	Deviation	Possible causes	Consequences	Safeguards	Comments	Actions required	Action allocated to
1	Input signal	Amplitude	NO	No signal detected	Transmitter failure	Considered in separate study of trackside equipment			Review output from trackside equipment study	DJ
2	Input signal	Amplitude	MORE	Greater than design amplitude	Transmitter mounted too close to rail	May damage equipment	Checks to be carried out during installation		Add check to installation procedure	DJ
3	Input signal	Amplitude	LESS	Smaller than design amplitude	Transmitter mounted too far from rail	Signal may be missed	As above		Add check to installation procedure	DJ
4	Input signal	Frequency	OTHER THAN	Different frequency detected	Pick up of a signal from adjacent track	Incorrect value passed to processor	Currently none		Check if action is needed to protect against this	DJ
5	Antennae	Position	OTHER THAN	Antennae is in other than the correct location	Failure of mountings	Could hit track and be destroyed	Cable should provide secondary support		Ensure that cable will keep antennae clear of track	JB
6	Antennae	Voltage	MORE	Greater voltage than expected	Antennae short to live rail	Antennae and other equipment become electrically live			Check if there is any protection against this occurring	DJ

Table B.3 (continued)

STUDY TITLE: AUTOMATIC TRAIN PROTECTION SYSTEM								SHEET: 2 of 2		
REFERENCE DRAWING No.: ATP BLOCK DIAGRAM					REVISION No.: 1			DATE:		
TEAM COMPOSITION: DJ, JB, BA								MEETING DATE:		
PART CONSIDERED:				INPUT FROM TRACKSIDE EQUIPMENT						
DESIGN INTENT:				TO PROVIDE DATA TO PES VIA ANTENNAE GIVING INFORMATION ON SAFE SPEEDS AND STOPPING POINTS						
No.	Element	Characteristic	Guide word	Deviation	Possible causes	Consequences	Safeguards	Comments	Actions required	Action allocated to
7	Antennae	Output signal	OTHER THAN	A different signal is transmitted	Pick-up of stray signals from adjacent cabling	Incorrect signal may be acted upon			Ensure that there is adequate protection from cabling interference	JB
8	Tachometer	Speed	NO	No speed is measured	Sudden wheel lock	May show zero speed			Check protection against this	DJ
9	Tachometer	Speed	OTHER THAN	Other than correct speed is detected	Sudden release of locked wheels gives confusing signal	May show wrong speed			Check protection against this	BA
10	Tachometer	Speed	AS WELL AS	Many speeds indicated	Sudden changes in output caused by wheel spin	May cause action based on wrong speed			Check if this is a problem in practice	BA
11	Tachometer	Output voltage	NO	No output	Axles locked	May show zero speed			Check implications of this	DJ
12	Tachometer	Output signal	AS WELL AS	Confused output signal	Other signals mixed in	May indicate wrong speed			Investigate whether this is a credible failure	BA

#### B.4 Example involving emergency planning

Organizations make plans to deal with a variety of anticipated emergencies. These emergencies can vary from reaction to a bomb threat, the provision of emergency power supplies or the escape of personnel in the event of a fire. The validity and integrity of these plans can be tested in a variety of ways – typically by some form of rehearsal. Such rehearsals are valuable, but can be expensive and, by their very nature, disrupt normal working. Fortunately, real emergencies which test the system are rare and in any case, even rehearsals may not cover all possibilities.

HAZOP studies offer a relatively inexpensive way of identifying many of the deficiencies which may exist in an emergency plan, in order to supplement the experience obtained by the relatively infrequent rehearsal or the even rarer actual emergency itself.

On an offshore oil and gas platform there needs to be in place effective arrangements for Escape, Evacuation and Rescue (EER) in the event of potentially life-threatening incidents. These arrangements would aim to ensure that personnel are quickly alerted to the existence of a dangerous situation, are able to make their way rapidly to a safe muster point, then evacuate the platform preferably in a controlled manner by helicopter or lifeboat and then be rescued and taken to a place of safety. Effective EER arrangements are an essential part of an overall offshore installation system. Within typical EER arrangements there are usually a number of different stages (elements) such as:

- a) raising the General Purpose Alarm (GPA) by automatic instruments or manually by any operator;
- b) communicating the situation both to the local stand-by vessel and to onshore emergency services;
- c) personnel making their way along designated access routes to the muster point;
- d) mustering involving registration of personnel present;
- e) donning of survival equipment, etc.;
- f) await “Prepare to Abandon Platform Alarm” (PAPA) which has to be initiated by the Offshore Installation Manager (OIM) or his deputy;
- g) egress in which personnel make their way from the muster point to the chosen method of evacuation;
- h) evacuation normally by helicopter or by special forms of lifeboat;
- i) escape directly into the sea if the preferred means of evacuation is not available;
- j) rescue, where either personnel in a lifeboat or those who had escaped directly into the sea would be recovered and taken to a place of safety.



Table B.4 (continued)

No.	Element	Guide word	Deviation	Possible causes	Consequences	Safeguards	Comments	Actions required	Action by
5			Less electrical energy	Some loss of power	Alarms may not sound	Dedicated power supply	Unlikely	None	
6		AS WELL AS	As well as initiation	Initiation triggers other activities		Not possible with dedicated hard-wired circuit		None	
7			As well as electrical energy	Some energy in wrong form, e.g. spikes	Possible damage	Screened supply circuit		None	
8		PART OF	Part of inputs	Signal but no energy or energy but no signal	Personnel not alerted		Already considered above		
9		REVERSE	Reverse inputs  Reverse electrical energy	Reverse of alarm initiation  No constructive meaning			System as described does not include the sounding of an "all clear"	Develop an "all clear" system	
10	Inputs	OTHER THAN	Other than inputs	Multiple	Depends on inputs	Unlikely with dedicated shielded circuits	May need "battle proof" system	Consider Pyrotanax wiring	

**Table B.4** (continued)

No.	Element	Guide word	Deviation	Possible causes	Consequences	Safeguards	Comments	Actions required	Action by
11	Activities emit alarm and transmit to personnel	NO	No alarm sounded	Sound equipment failure  Cable damage	Personnel not alerted	Dual PA system  Dual cabling Dual power supplies Multiple speakers	Unlikely	None	
12		MORE	More alarm	Sound equipment too powerful	Personnel suffer ear damage	Sound equipment rated to not exceed safe level		None	
13		LESS	Less alarm	Sound too weak	Some personnel not alerted	None		Ensure system provides a minimal of 15 dB above background	
14		AS WELL AS	As well as alarm and transmit	Distortion of alarm, overtones or echoes	Lack of clear-cut signal to personnel	None		Investigate need for acoustic engineering	
15		PART OF	Part of alarm transmit	Alarms but transmission inadequate	No signal to personnel		As for less alarm above		
16		REVERSE	Reverse alarm and transmit				See comments above reverse initiations and "all clear"		

**Table B.4** (continued)

No.	Element	Guide word	Deviation	Possible causes	Consequences	Safeguards	Comments	Actions required	Action by
17		OTHER THAN	Other than emit GPA alarm and transmit	System initiates "PAPA" by mistake	Confusion amongst personnel. Some may abandon platform by mistake	None		Review signal logic so that PAPA can only be sounded after GPA	
18		SOONER	Alarm and transmit sounded too soon	GPA initiated before situation requires this action	Unnecessary alarm and disruption of work	None		Establish clear guidelines for platform personnel	
19		LATER	Alarm and transmit sounded too late	GPA initiation after situation required this action	Some personnel may be trapped or forced to use alternative and less desirable route	None		Clear guidelines as above	

## B.5 Piezo valve control system

The piezo valve control system (see simplified Figure B.3) shows how HAZOP can be applied to a detailed electronic system.

A piezo valve is a valve driven by a piezo ceramic. The ceramic element is electrically driven and lengthens itself in the charged state. A charged piezo ceramic closes the valve. A discharged piezo ceramic opens the valve. If the piezo ceramic does not lose or gain charge, the state of the valve is kept.

The system sprays a flammable and explosive liquid into a reaction vessel (not shown). The overall system with reactor vessel, pipes, pumps, etc. is part of a separate HAZOP study. Here only the application of a HAZOP study to an electronic unit is shown.

The operation of the unit is a two-state process designed to close the valve on demand, "state 1", and open it on demand, "state 2".

An electrical charge from capacitor C1 is conducted via the transistor T1 to the coupling capacitor C2 and via the power wire to the piezo valve to close it. In this case transistor T2 and the protection transistor T3 are closed (high resistance).

Capacitor C2 is discharged by transistor T2 to open the valve. To prevent asymmetric charging of the piezo valve, for example by mechanical or thermal stress, transistor T4 connects the low side to ground.

An electrical shield around the twisted wires of the cable prevents electro-magnetic influences from effecting the valve.



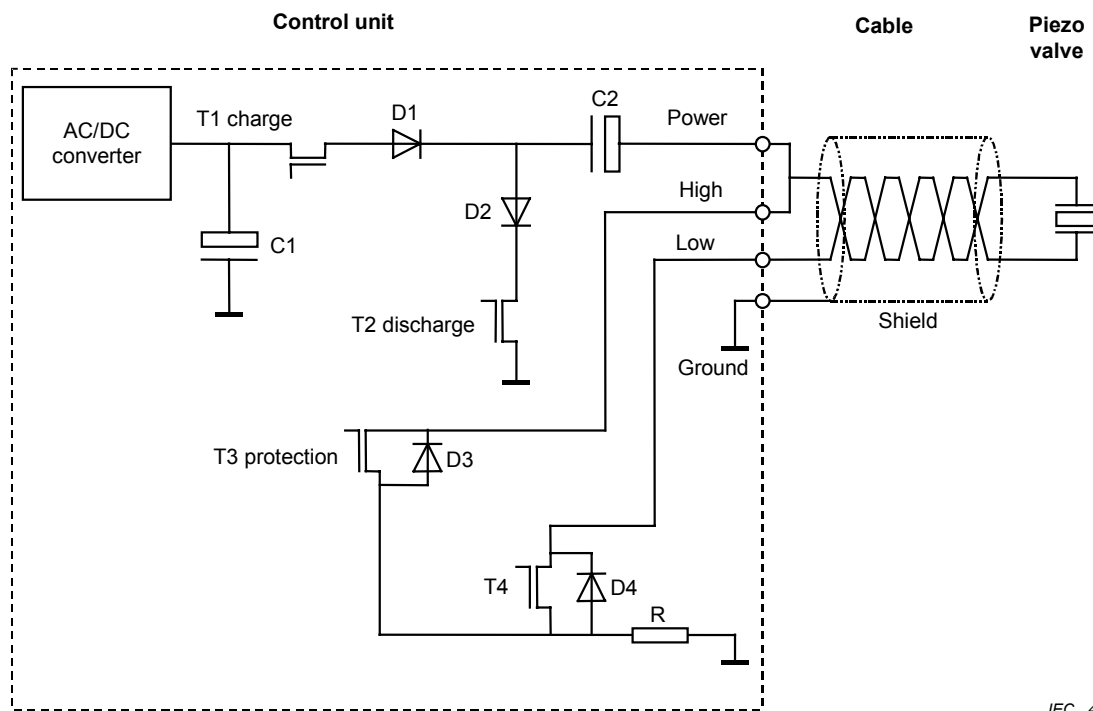

IEC 455/01

Figure B.3 – Piezo valve control system

**Description of state 1:** close valve

**Part considered:** cable from AC/DC converter and from capacitor C1 via transistor T1, diode D1, capacitor C2 to the power side of the valve and from the ground side of the valve via transistor T4 and resistor R to ground.

**Description of state 2:** open valve

**Part considered:** cable from power side of valve via transistor T3, diode D3 and resistor R to ground.

The design intent is as follows.

Input	Activity	Source	Destination
State 1: Close valve 1. Charge in C1	1. Transfer charge via T1, D1 and C2	C1 and converter	1. Power to power side of valve
Characteristics: Voltage Capacity	2. Transfer charge via T4 and R to ground	Low side of valve	2. Low side charge to ground
2. Control signals to T1, T3 and T4	3. Control opening via T1 and T4 from ground 4. Isolated via T2 5. Prevent overcharge via T3	Signal from controller	T1, T3 and T4  Overcharge to ground
	6. Prevent reverse flow of charge via D2	Power side of valve	
State 2: Open valve 1. Discharge power side of valve Characteristics: Voltage Capacity	1. Isolate from C1 and converter via T1 2. Transfer power charge via D2 and T2 3. Transfer any charge of valve via D3, D4 and R	Power side of valve and C2	Ground
2. Control signals to T1, T2 and T4	4. Isolate low charge side of valve via T4	Signals from controller	T1, T2 and T4

**Table B.5 – Example HAZOP worksheet for piezo valve control system**

<b>STUDY TITLE:</b> PIEZO VALVE CONTROL SYSTEM							<b>SHEET:</b> 1 of 3	
<b>Drawing No:</b>			<b>REVISION No.:</b>			<b>DATE:</b>		
<b>TEAM COMPOSITION:</b> Development engineer, System engineer, Quality manager							<b>MEETING DATE:</b> 04.11.97	
<b>Part considered:</b>		State 1: System closes valve						
<b>Design intent:</b>		Transfer a defined quantity of electrical charge to the piezo actuator to close the valve at a defined time						
<b>Element</b>	<b>Guide word</b>	<b>Deviation</b>	<b>Possible causes</b>	<b>Consequences</b>	<b>Safeguards</b>	<b>Comments</b>	<b>Actions required</b>	<b>Action allocated to</b>
Input: Charge in C1	NO	No charge; including don't transfer	Power outage Failure of converter Fault in C1 T1 is permanently closed T2 is permanently open T1 faulty Diodes (D1, D3) failure: – Diode D1 with open circuit; no current flows – Diode D3 shortened; shortcut via D4 to low side of piezo valve or via R to ground C2 faulty Broken wires T4 faulty R faulty T3 faulty	No flow via C2 into piezo valve  Valve does not close; permanently open  Reactive material running into the vessel	None	Situation not acceptable  Design change required	High-level alarm  Test routine	J. Smith

Table B.5 (continued)

<b>STUDY TITLE:</b> PIEZO VALVE CONTROL SYSTEM							<b>SHEET:</b> 2 of 3	
<b>Drawing No.:</b>			<b>REVISION No.:</b>			<b>DATE:</b>		
<b>TEAM COMPOSITION:</b> Development engineer, System engineer, Quality manager							<b>MEETING DATE:</b> 04.11.97	
<b>Part considered:</b>		State 1: System closes valve						
<b>Design intent:</b>		Transfer a defined quantity of electrical charge to the piezo actuator to close the valve at a defined time						
Element	Guide word	Deviation	Possible causes	Consequences	Safeguards	Comments	Actions required	Action allocated to
Input: Charge in C1	MORE	More charge than defined	Charge in C2 too high Faulty converter Transistor T1 does not close in time C2 faulty AC/DC converter delivers too high voltage Transistor T1 does not close in time Faulty protection T3	Piezo valve closes earlier than defined Damaged piezo valve	Flow meter shows too high quantity; transistor T3 discharges piezo valve; None shown	Situation not acceptable	Consider high level alarm	Peter Peterson
Charge in C1	LESS	Less charge than specified	Insufficient capacity exists; Faulty insulation of cable; charge disappears T1 closes too early T2 is partly open	Insufficient charge in C2 Valve closes later than specified	None	Situation not acceptable	Alarm	J. Smith

**Table B.5** (continued)

<b>STUDY TITLE:</b> PIEZO VALVE CONTROL SYSTEM							<b>SHEET:</b> 3 of 3	
<b>Drawing No:</b>				<b>REVISION No.:</b>			<b>DATE:</b>	
<b>TEAM COMPOSITION:</b> Development engineer, System engineer, Quality manager							<b>MEETING DATE:</b> 04.11.97	
<b>Part considered:</b>		State 1: System closes valve						
<b>Design intent:</b>		Transfer a defined quantity of electrical charge to the piezo actuator to close the valve at a defined time						
<b>Element</b>	<b>Guide word</b>	<b>Deviation</b>	<b>Possible causes</b>	<b>Consequences</b>	<b>Safeguards</b>	<b>Comments</b>	<b>Actions required</b>	<b>Action allocated to</b>
Input: Charge in C1	AS WELL AS	T1 as well as T2 is open	Less charge to C2 Valve does not close Reactive material runs into the reaction vessel	Uncontrolled chemical reaction	None shown	Small differences may be acceptable	Alarm Test routine Reset Define acceptable differences	J. Smith

## B.6 Oil vaporizer

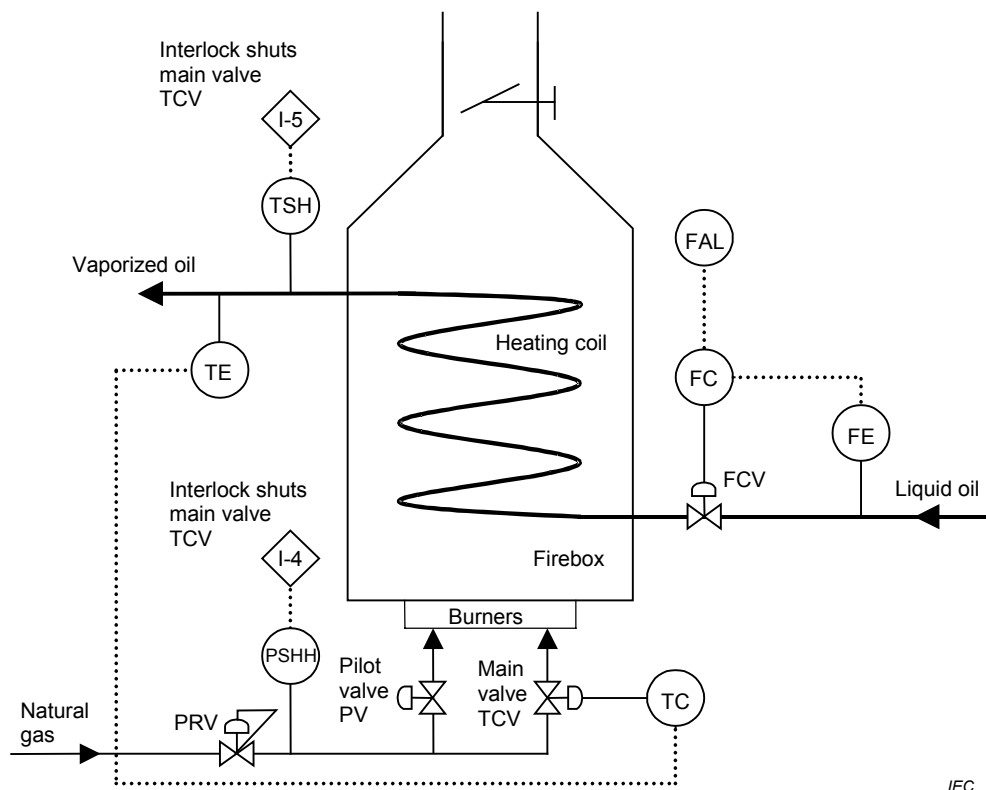

IEC 456/01

Figure B.4 – Oil vaporizer

The oil vaporizer consists of a furnace containing a heating coil and burners, which are fired by natural gas.

The oil enters the heating coil as a liquid, is evaporated, and leaves the coil as a superheated vapour.

The natural gas entering the burners combines with external air and burns in a hot flame. The combustion gases leave through the stack.

The oil flow is controlled by a flow control set which includes: a flow control valve, FCV, a flow element, FE, that measures the oil flow, a flow controller, FC, and a low flow alarm, FAL, which alarms if the oil flow reduces below a set point.

The natural gas flow passes through a self-actuating pressure-reducing valve, PRV, to the main burner control valve TCV, and a pilot valve PV. The main burner control valve is actuated by the temperature controller TC which receives the signal from the temperature element TE, which measures the oil vapour discharge temperature.

The high/high pressure switch, PSHH on the natural gas line is interlocked, via I-4 to close the main burner control valve, TCV, if the gas pressure is too high. There is also a high temperature switch, TSH, on the vaporized oil outlet to close the main burner control valve, TCV, if the oil is superheated above a maximum temperature. Finally, there is a flame detector device (not shown) which will close both gas valves should the flame go out.

**Table B.6 – Example HAZOP worksheet for oil vaporizer**

STUDY TITLE: OIL VAPORIZER										
Drawing No. :					REVISION No.:			DATE:		
TEAM COMPOSITION: MG, NE, DH, EK, LB								MEETING DATE:		
PART CONSIDERED: Vaporizer coil from oil inlet (before flow measurement), to vapour exit to process (after temperature control)					DESIGN INTENT:		Inputs: Oil flow from the feed line, heat from the furnace Activities: Vaporize, superheat and transfer oil vapour to the process			
No.	Guide word	Element	Deviation	Possible causes	Consequences	Safeguards	Comments	Actions required	Action by	
1	No	Oil flow	No oil flow	<ul style="list-style-type: none"> <li>- Supply failure</li> <li>- Flow control valve PCV closed</li> </ul>	Vaporizer coil overheats and may fail	Low flow alarm FAL  High temperature trip TSH	Safeguard depends on quick operator response	Consider low flow element FE to close main burner valve TCV	LB	
				<ul style="list-style-type: none"> <li>- Plugging of coil</li> <li>- Blockage down-stream of vaporizer</li> </ul>	Oil in vaporizer will boil: Possible overheating and coking of heating coil	Low flow alarm FAL  High temperature trip TSH		Check whether these safeguards are adequate and the ease with which the coil could be cleaned	NE	
2	No	Heat	No heat	Flame out in the furnace	Unvaporized liquid oil fed to the process	None		<ul style="list-style-type: none"> <li>- Investigate effect of liquid oil on the process</li> <li>- Consider interlocking the furnace flame out signal with closure of FCV</li> <li>- Consider providing a low oil outlet temperature alarm</li> </ul>	DH	

Table B.6 (continued)

No.	Guide word	Element	Deviation	Possible causes	Consequences	Safeguards	Comments	Actions required	Action by
3	More	Oil flow	More oil flow	<ul style="list-style-type: none"> <li>- Oil delivered at higher pressure</li> <li>- Failure of flow controller FC</li> <li>- Wrong set point of FC</li> </ul>	May overload vaporizer, resulting in insufficient heating of oil stream (see point 6)	None		<ul style="list-style-type: none"> <li>- Check capability of FCV to control flow of oil at higher pressure</li> <li>- Consider providing a low oil outlet temperature alarm</li> </ul>	MG
4	More	Heat	More heat	Furnace temperature too high	- Vaporizer coil overheats: possible coking of oil and plugging	High temperature switch TSH closes main burner valve TCV		Review safeguards of gas flow controls	EK
					- Oil vapour at too high temperature delivered to the process	High temperature switch TSH closes main burner valve TCV		Check the effect of high vapour temperature on process	DH
5	Less	Oil flow	Less oil flow	Low delivery pressure	Same as point 4	Same as point 1	Safeguards adequate	No action	
6	Less	Heat	Less heat	Low output from furnace	May fail to vaporize or superheat oil. Oil with low temperature delivered to process	None	Does this matter?	Check the effect of unvaporized or low superheat oil on process	DH
								Consider providing a low oil outlet temperature alarm	EK



**Table B.6** (continued)

No.	Guide word	Element	Deviation	Possible causes	Consequences	Safeguards	Comments	Actions required	Action by
7	As well as	Oil	As well as oil	Impurities in oil, e.g.	Rapid boiling of water may eject liquid oil into process	None		Check potential water content of oil	DH
				<ul style="list-style-type: none"> <li>- Water</li> <li>- Solids, nonvolatiles, corrosives or unstable compounds in oil</li> </ul>	Potential for partial or complete plugging of coil (see point 1), carbon layer, or corrosion and leakage (see point 11)	None		Check potential impurities	DH
8	Reverse	Oil flow	Reverse flow	Loss of feed may permit back-flow of oil vapour from the process into the coil and the oil feed system	Possible overheating of feed and damage to feed system	None		Review implications on unit and consider installing back flow prevention	DH
9	Other than	Oil	Other than oil	Totally wrong material fed to vaporizer	Depends on material	Upstream control of inputs		Check whether controls are adequate	EK

Table B.6 (continued)

No.	Guide word	Element	Deviation	Possible causes	Consequences	Safeguards	Comments	Actions required	Action by
10	Other than	Vaporize	Possible explosion in the furnace	Ignition of a mixture of natural gas and air	Vaporizer destroyed Major fire fed from oil supply	Interlocks, etc. on furnace	Safeguards may not be adequate	<ul style="list-style-type: none"> <li>- Consider installing a fire shut-off valve on oil supply</li> <li>- Review safeguards on furnace preventing explosion</li> </ul>	NE
11	Other than	Oil flow	Vapour oil flow to other than the process inlet	<ul style="list-style-type: none"> <li>- Leakage</li> <li>- Failure of coil</li> </ul>	<p>Major fire in furnace fed from oil supply and back flow of oil vapour from process.</p> <p>Emission of fumes and smoke.</p> <p>Probably damage of the fire box</p>	None		<ul style="list-style-type: none"> <li>- Consider installing a fire shutoff valve on oil supply</li> <li>- Provide for emergency snuffing steam to the furnace</li> <li>- Consider installing a high temperature alarm or trip in the stack to shut gas supply valves</li> <li>- Ensure routine inspection of coil</li> </ul>	NE

## Bibliography

- (1) *A Guide to Hazard and Operability Studies*. Chemical Industries Association, London, UK, (1977), 1992.
- (2) *Das PAAG-Verfahren*. International Social Security Association, (ISSA), c/o B.G. Chemie, Heidelberg, Germany, 2000, ISBN 92-843-7037-X.
- (3) *Storingsanalyse Waarom? Wanner? Hoe?* Dutch Labour Inspectorate, 1979. Body of text in Dutch, appendices in English.
- (4) Kletz, Trevor A. *HAZOP and HAZAN – Identifying and Assessing Chemical Industry Hazards*, Institution of Chemical Engineers, Rugby, UK, 1999, ISBN 0-85295-421-2.
- (5) Knowlton, Ellis. *An Introduction to Hazard and Operability Studies, the Guide Word Approach*, Chemetics International, Vancouver, Canada, 1992, ISBN 0-9684016-0-0. (Also available in French, Spanish, Finnish, Arabic, Chinese, Hindi and Korean).
- (6) Knowlton, Ellis. *A manual of Hazard & Operability Studies, The creative identification of deviations and disturbances*. Chemetics International, Vancouver, Canada, 1992, ISBN 0-9684016-3-5.
- (7) Redmill, Felix; Chudleigh, Morris and Catmur, James. *System Safety: HAZOP and Software HAZOP*. Wiley, 1999, ISBN 0-471-98280-6.
- (8) Crawley, Frank; Preston, Malcolm and Tyler, Brian, *HAZOP: Guide to best practice. Guidelines to best practice for the process and chemical industries*. European Process Safety Centre, Chemical Industries Association & Institution of Chemical Engineers. Rugby, England, IChem, 2000, ISBN 0-85295-427-1.
- (9) *Guidelines for Hazard Evaluation Procedures*. Center for Chemical Process Safety of the American Institute of Chemical Engineers, New York, USA, 1999, ISBN 0-8169-0491-X.
- (10) *Defence Standard 00-58, HAZOP Studies on Systems containing Programmable Electronics*, Ministry of Defence, UK, 2000.

---

---

---

## BSI — British Standards Institution

BSI is the independent national body responsible for preparing British Standards. It presents the UK view on standards in Europe and at the international level. It is incorporated by Royal Charter.

### Revisions

British Standards are updated by amendment or revision. Users of British Standards should make sure that they possess the latest amendments or editions.

It is the constant aim of BSI to improve the quality of our products and services. We would be grateful if anyone finding an inaccuracy or ambiguity while using this British Standard would inform the Secretary of the technical committee responsible, the identity of which can be found on the inside front cover.  
Tel: 020 8996 9000. Fax: 020 8996 7400.

BSI offers members an individual updating service called PLUS which ensures that subscribers automatically receive the latest editions of standards.

### Buying standards

Orders for all BSI, international and foreign standards publications should be addressed to Customer Services. Tel: 020 8996 9001. Fax: 020 8996 7001. Standards are also available from the BSI website at <http://www.bsi-global.com>.

In response to orders for international standards, it is BSI policy to supply the BSI implementation of those that have been published as British Standards, unless otherwise requested.

### Information on standards

BSI provides a wide range of information on national, European and international standards through its Library and its Technical Help to Exporters Service. Various BSI electronic information services are also available which give details on all its products and services. Contact the Information Centre.  
Tel: 020 8996 7111. Fax: 020 8996 7048.

Subscribing members of BSI are kept up to date with standards developments and receive substantial discounts on the purchase price of standards. For details of these and other benefits contact Membership Administration.  
Tel: 020 8996 7002. Fax: 020 8996 7001. Further information about BSI is available on the BSI website at <http://www.bsi-global.com>.

### Copyright

Copyright subsists in all BSI publications. BSI also holds the copyright, in the UK, of the publications of the international standardization bodies. Except as permitted under the Copyright, Designs and Patents Act 1988 no extract may be reproduced, stored in a retrieval system or transmitted in any form or by any means – electronic, photocopying, recording or otherwise – without prior written permission from BSI.

This does not preclude the free use, in the course of implementing the standard, of necessary details such as symbols, and size, type or grade designations. If these details are to be used for any other purpose than implementation then the prior written permission of BSI must be obtained.

If permission is granted, the terms may include royalty payments or a licensing agreement. Details and advice can be obtained from the Copyright Manager.  
Tel: 020 8996 7070.