

LYMPHOID ORGANS AND LYMPHOCYTE HOMING

October 25th 2024

The dynamic life of lymphocytes

Il materiale contenuto in questo documento è distribuito a uso
interno e a puro scopo didattico

How is the immune system anatomically organized?

What role does cell migration play in the immune system and how?

The immune system consists of:

Cells of the adaptive/acquired compartment (**B and T lymphocytes**) and of the innate compartment with accessory and /or effector function (i.e. **mononuclear phagocytes, dendritic cells, Natural Killer cells**)

Different organs distributed throughout the body that function as generation (maturation) sites, deposits or transit/information stations of immune cells

A system of **blood vessels** and **lymphatic vessels** that forms interconnections between these organs allowing their functional union

PRIMARY lymphoid organs are the maturation sites of immune cells in the absence of exogenous antigen

- **Thymus** is the site of maturation of T lymphocytes
- **Bone marrow** is the site of production of mature B lymphocytes in mammals as well as the site where all **hematopoietic cells** are generated.

Hematopoietic system is responsible for the continuous production of blood circulating mature cells

SECONDARY (or peripheral) lymphoid organs are the sites where mature lymphocytes differentiate in a manner dependent on exogenous antigens:

- The main function of the **lymph nodes** is to respond to the antigens introduced into the tissues connected to them through the lymphatic vessels
- The main function of the **spleen** is to respond to the blood antigens
- **MALT (Mucosal-associated Lymphoid tissue)** protects against pathogens in the most important entry points (mucosa of the gastro-intestinal tract and respiratory tract)

Human lymphoid system

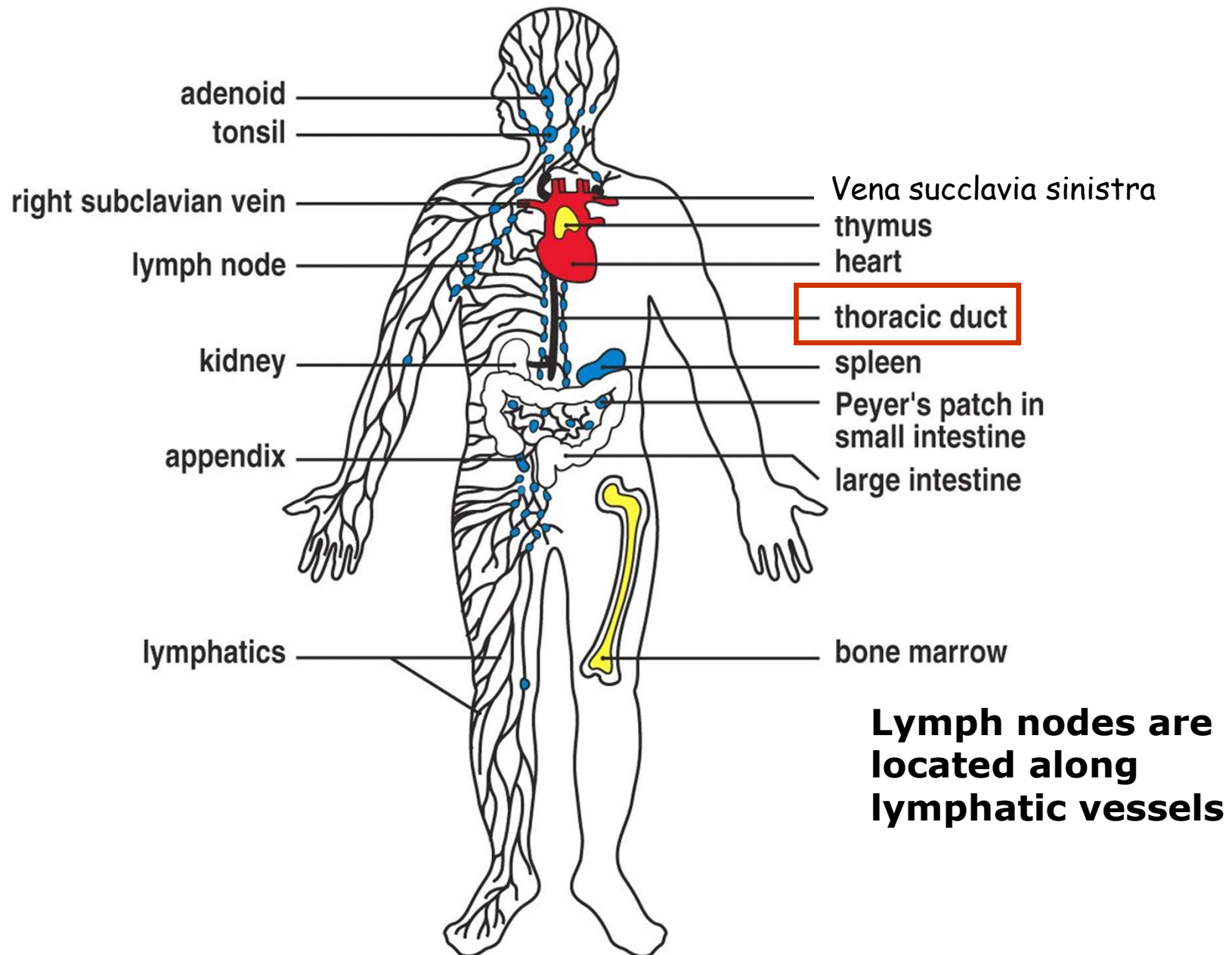

Differentiation of mature lymphocytes in primary lymphoid organs and recirculation in secondary lymphoid organs

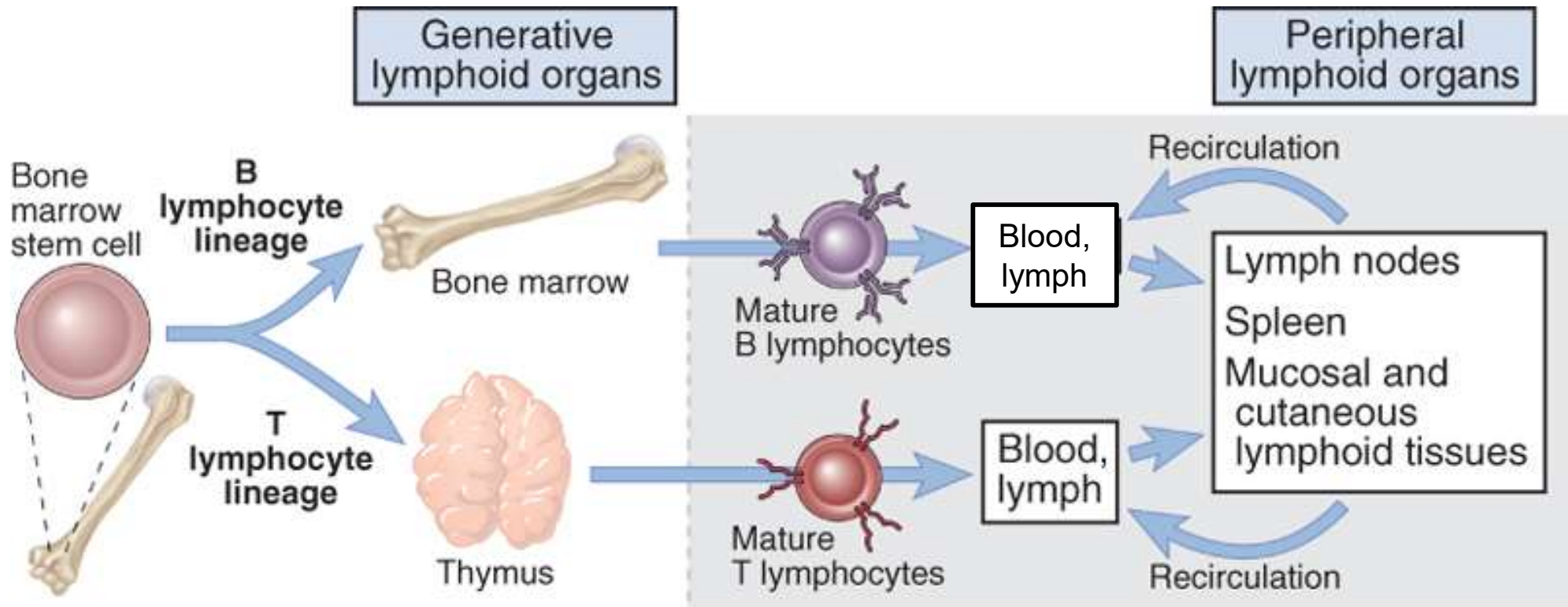

© Elsevier. Abbas et al: Cellular and Molecular Immunology 6e - www.studentconsult.com

Following maturation, naive (mature) T and B lymphocytes make a cyclical path from blood into lymphoid organs and reverse until recognition of the antigen.

When activated, they differentiate into effector or memory cells and change their itinerary.

What is the lymph?

The blood capillaries of many tissues have micro-leaks.

This involves the daily passage of 20 liters of protein-poor fluids into the extra-vascular space.

About 90% of these fluids are reabsorbed locally while the remaining 2 liters return to the circulation through the lymphatic vessels. These vessels have valves that allow unidirectional flow through the lymph nodes into the body cavities.

The passage of interstitial fluids (lymph) through lymph vessels of ever increasing caliber ends in the **thoracic duct**.

The pressure due to breathing or compression that follows muscle contraction pushes the lymph that eventually spills into the bloodstream mainly through the **left subclavian vein**

THE ROUTES OF ANTIGEN ENTRANCE AND TRANSPORTATION TO THE SECONDARY Lymphoid ORGANS

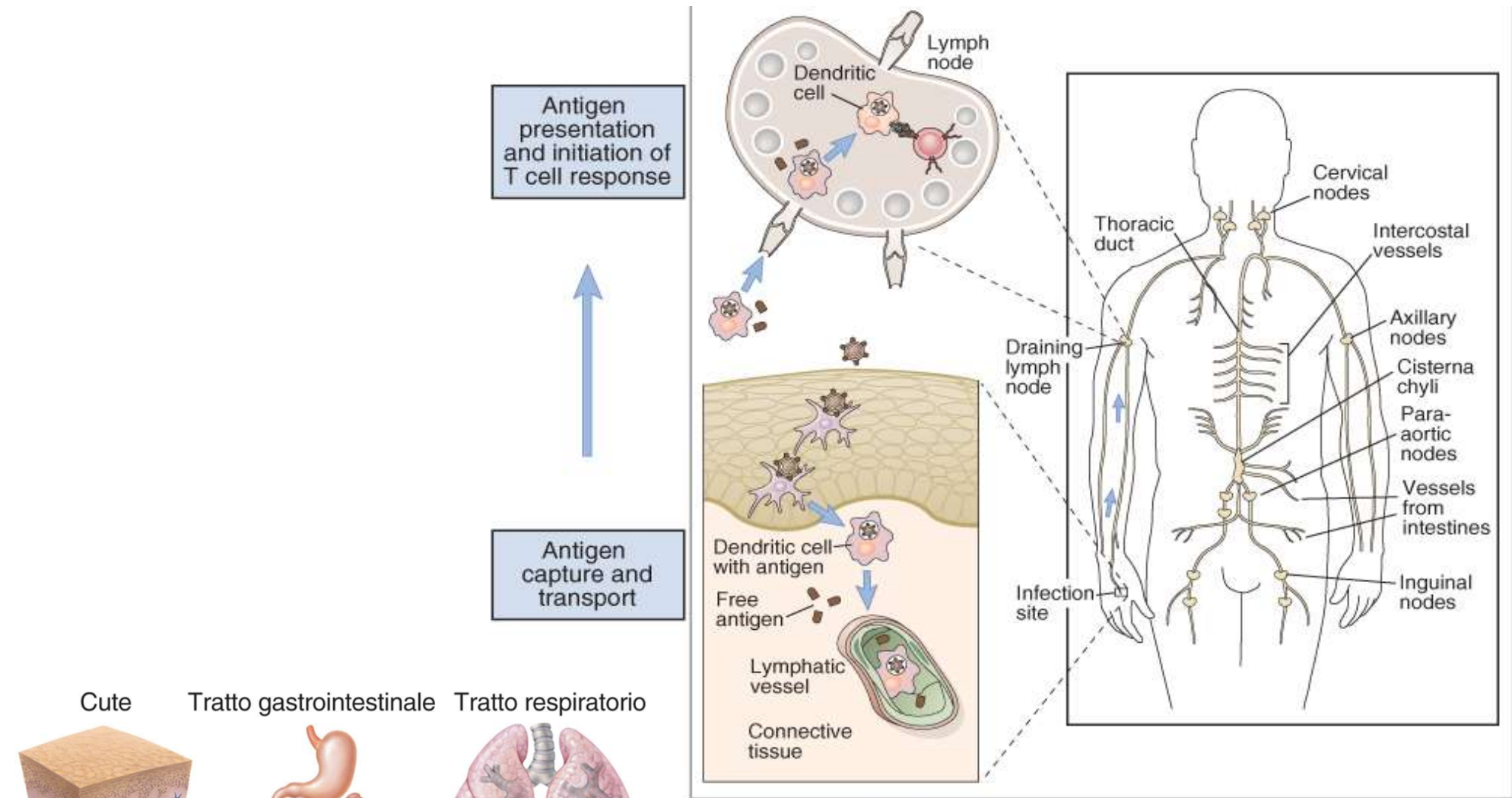

The lymphatic system

Lymph nodes are regularly found along lymphatic vessels and act as filter controlling lymph before it reaches the bloodstream.

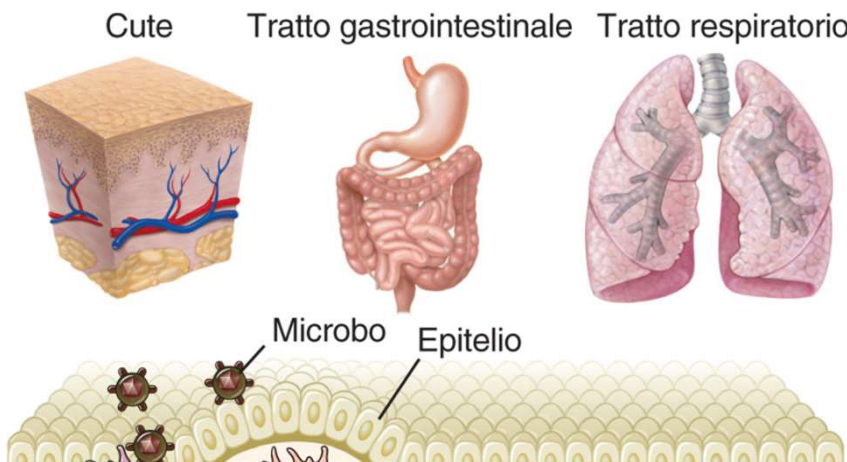

Secondary lymphoid organs

Organization in anatomical sites

Lymph node structure

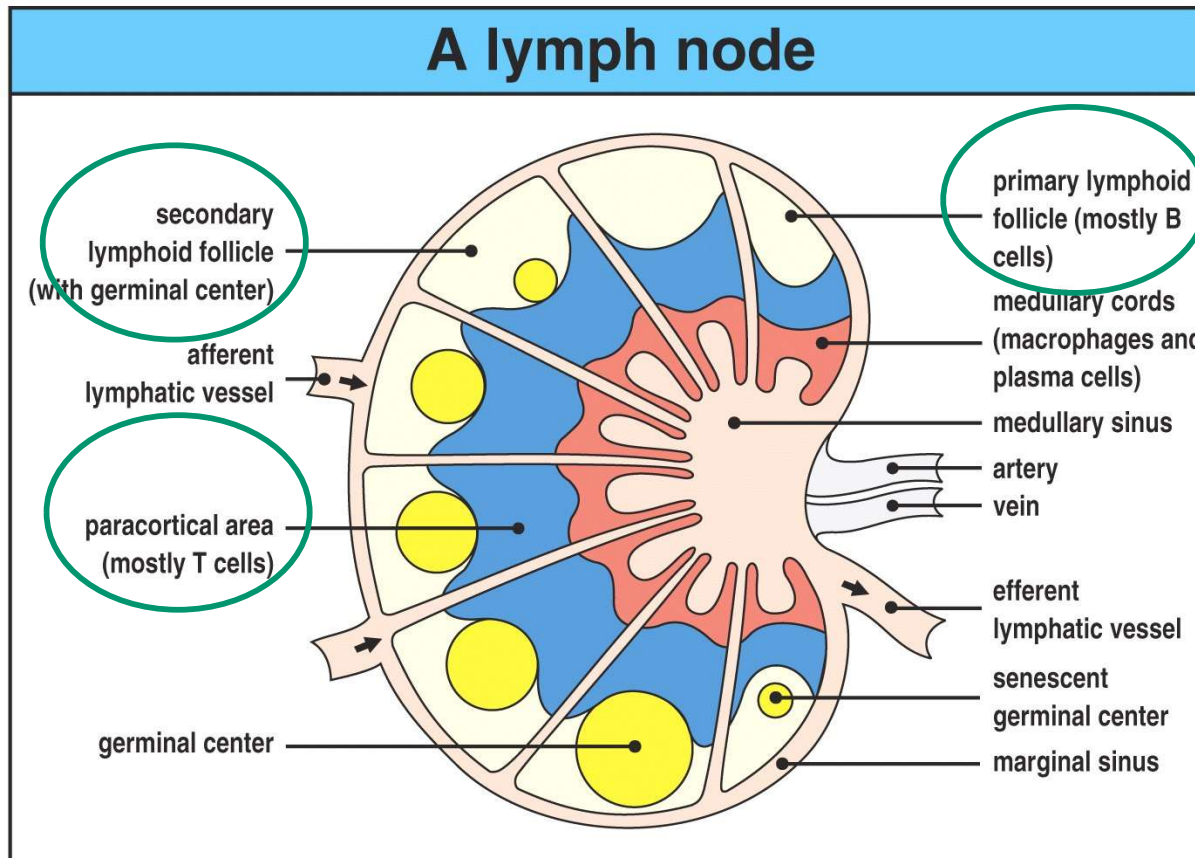

Figure 1-8 part 1 of 2 Immunobiology, 6/e. (© Garland Science 2005)

It is coated with a capsule made up of collagen fibers. The lymph flows into the **subcapsular sinus** carrying lymphocytes, dendritic cells and macrophages and soluble antigens

Follicles with germinal centers are present in the **cortical area** in which the B cells mature in plasma cells after activation.

T lymphocytes are predominantly found in the **paracortical area**. The **medullary zone** contains predominantly plasma cells and macrophages

Follicular Dendritic Cells (FDC) are stromal cells of non-haematopoietic origin resident in follicles where they have the function of 1) presenting an intact antigen to B lymphocytes to select effector and memory B cells and 2) maintaining B lymphocytes in the follicle.

How is molecule content in lymph node influenced by peripheral tissue environment?

A conduit system transports low molecular weight soluble antigens and chemokines to the T cell area and HEV

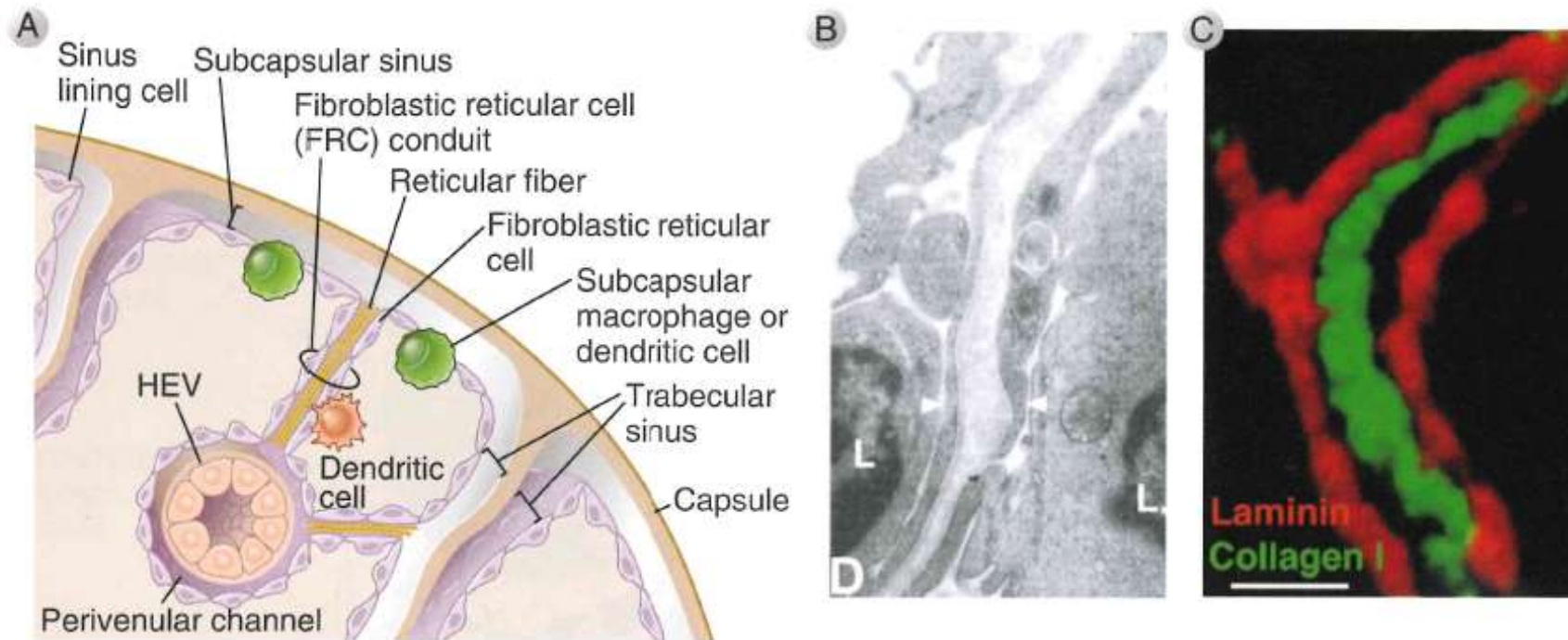

FIGURE 2.16 Microanatomy of the lymph node cortex. **A**, Schematic of the microanatomy of a lymph node depicting the route of lymph drainage from the subcapsular sinus, through fibroreticular cell conduits, to the perivenular channel around the HEV. **B**, Transmission electron micrograph of a FRC conduit surrounded by fibroblast reticular cells (arrowheads) and adjacent lymphocytes (L). (From Gretz JE, Norbury CC, Anderson AO, Proudfoot AEI, Shaw S: Lymph-borne chemokines and other low molecular weight molecules reach high endothelial venules via specialized conduits while a functional barrier limits access to the lymphocyte microenvironments in lymph node cortex, *The Journal of Experimental Medicine* 192:1425–1439, 2000.) **C**, Immunofluorescent stain of an FRC conduit formed of the basement membrane protein laminin (red) and collagen fibrils (green). HEV, High endothelial venule. (From Sixt M, Nobuo K, Seig M, Samson T, Roos G, Reinhardt DP, Pabst R, Lutz M, Sorokin L: The conduit system transports soluble antigens from the afferent lymph to resident dendritic cells in the T cell area of the lymph node, *Immunity* 22:19–29, 2006. Copyright © 2005 by Elsevier Inc.)

High molecular weight molecules do not enter into the conduits, but are captured and transported by accessory cells

The anatomical segregation of lymphocytes in the cortical (follicle) and paracortical areas favors the appropriate responses to the antigens because each lymphocyte population is in close contact with its own accessory cells

Red: **T cells**
(interact with DC)

Green: **B cells**
(interact with FDC
And few Tfh cells

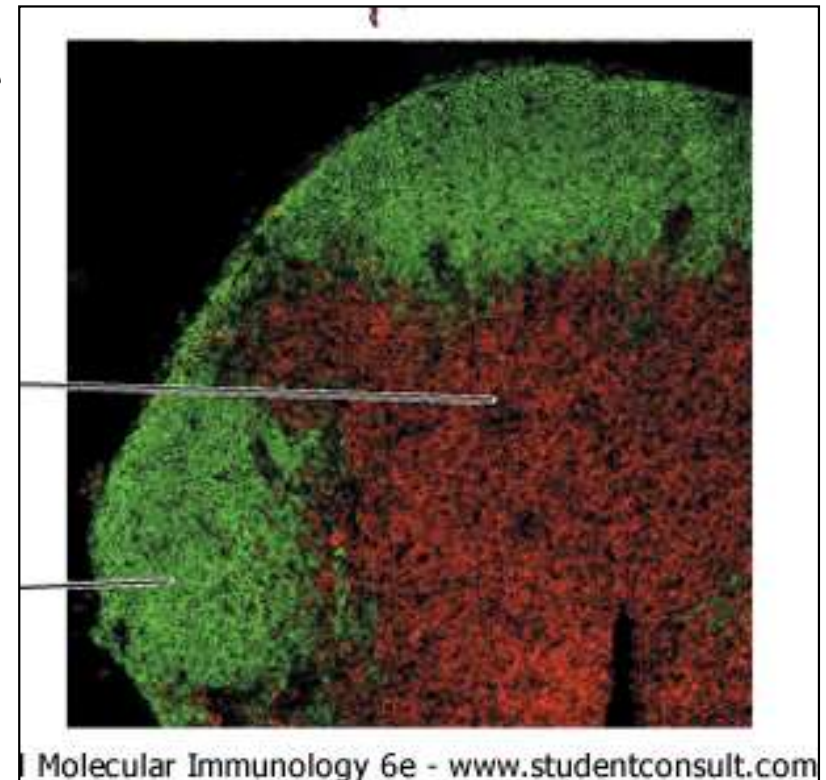

HOW IS IT OBTAINED?

A fundamental role is played by the interaction of chemoattractant molecules of the chemokine family with their receptors.

Chemokines

... are a family of molecules with high sequence homology whose structure and nomenclature depends on conserved cysteines. Depending on the motif associated with the first two cysteines, they have been classified into 4 classes

CXC or alpha

CC or beta

C or gamma

CX3C

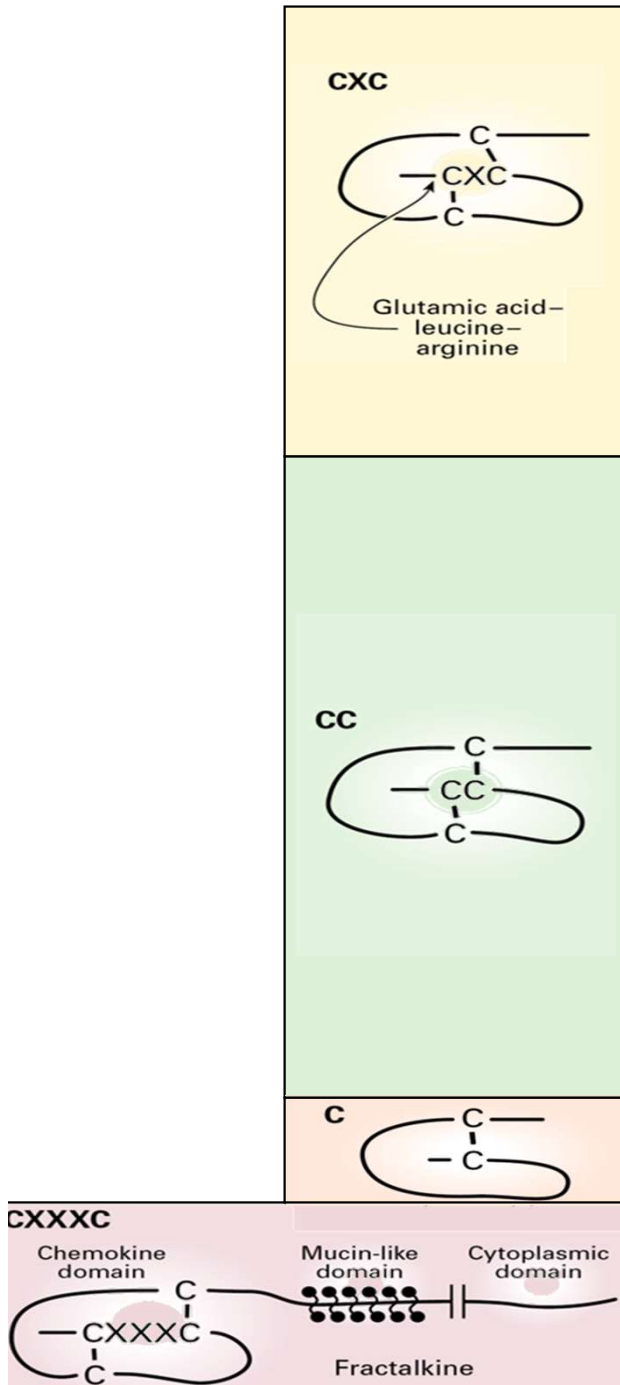

Chemokine receptors are classified based on the chemokine class they bind into:
CC, CXC, CX3C and C receptors

G protein-coupled receptor signaling

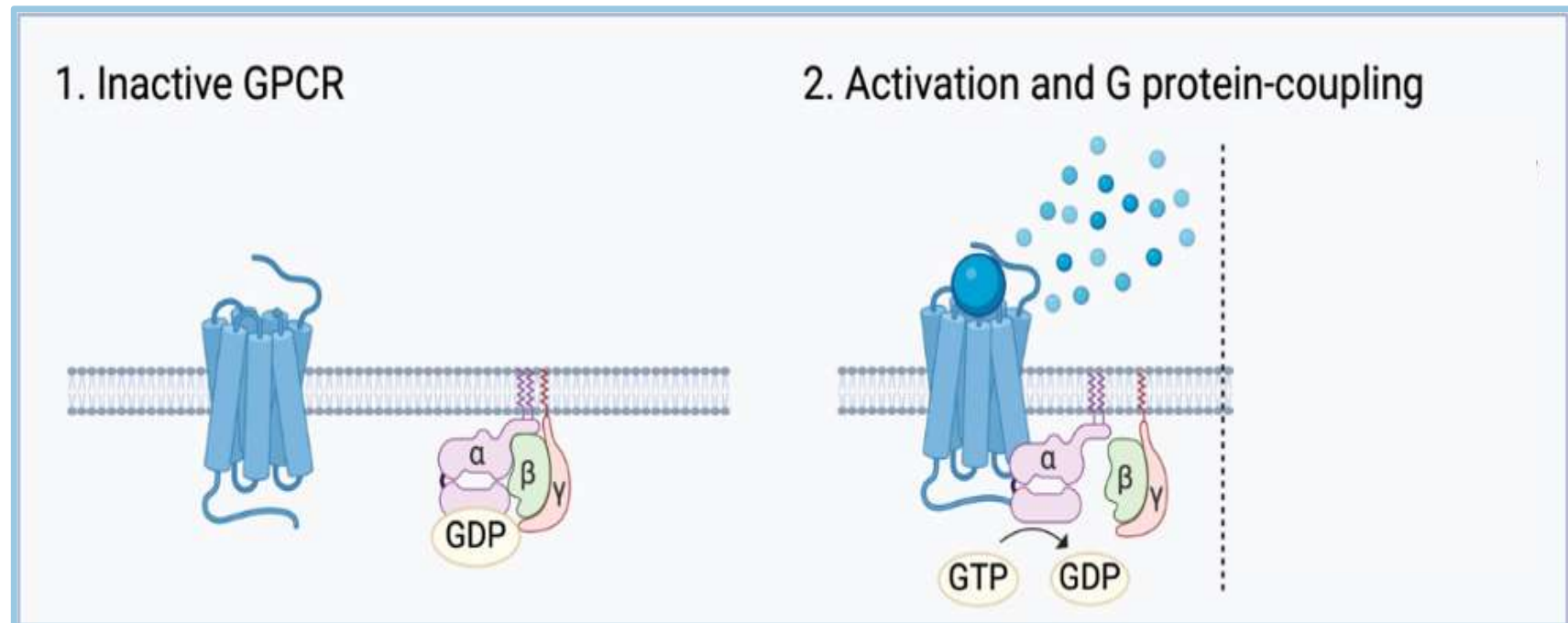

Chemokines and chemokine receptors

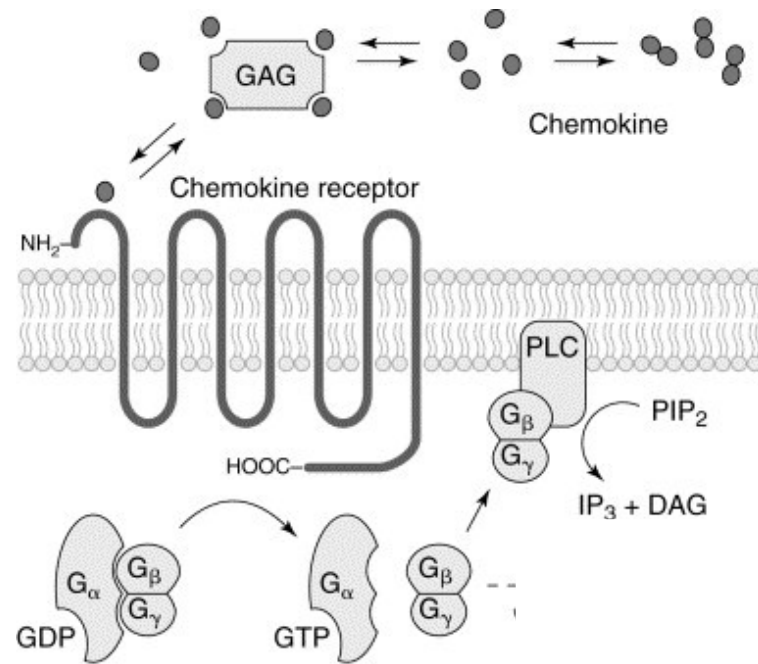

*GAG: Glycosaminoglycans
Usually exposed by
endothelial cells*

Cellular responses:
migration (chemotaxis), proliferation, cytokine release,
receptor regulation, degranulation, respiratory burst

a Leukocyte chemotaxis

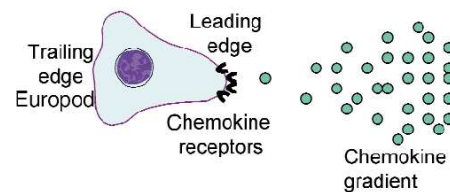

b Integrin activation during leukocyte-endothelial interactions

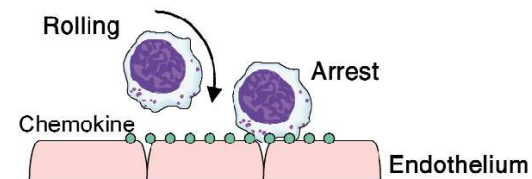

Anatomical segregation of lymphocytes

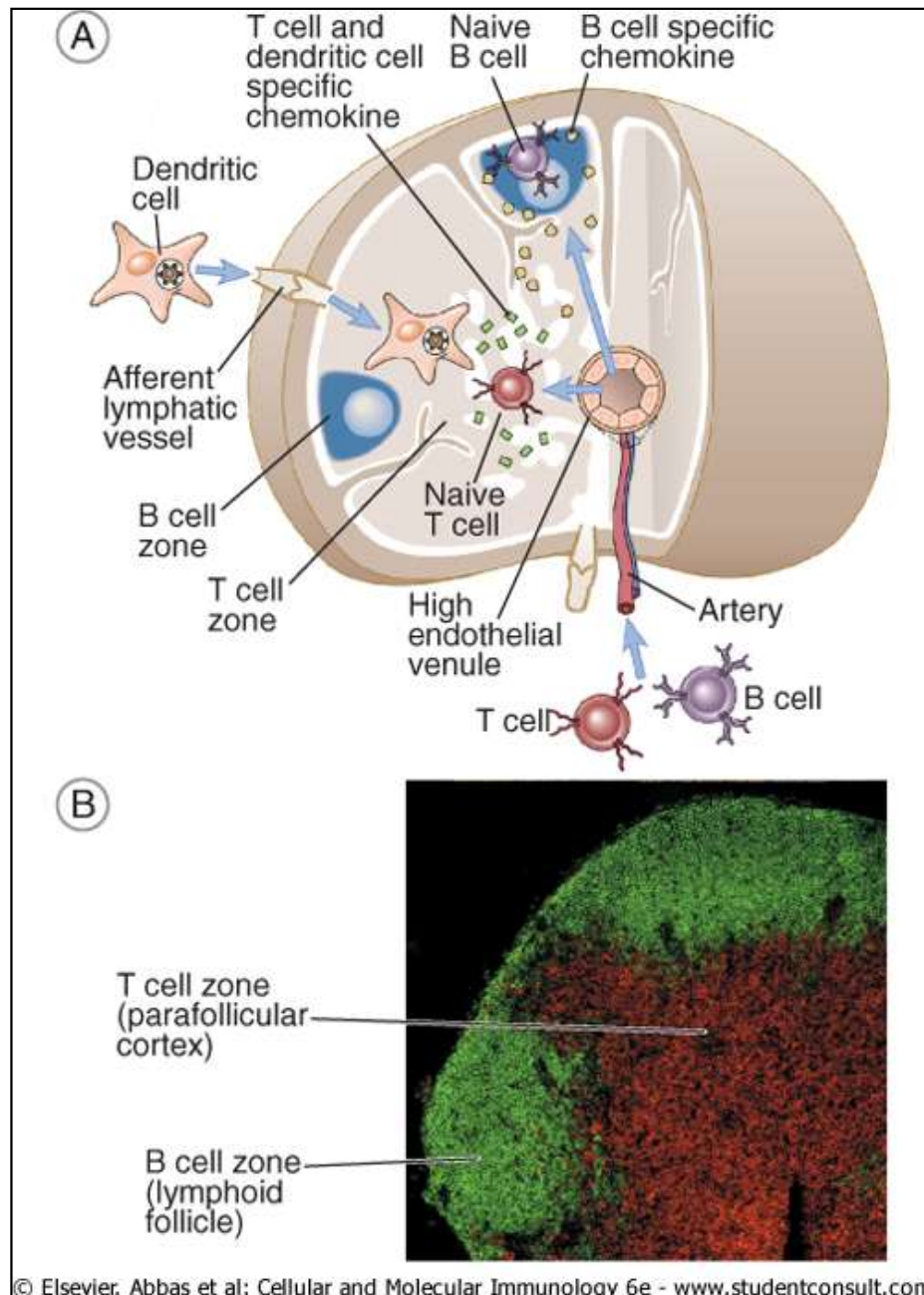

Chemokines are small **secreted proteins with chemotactic activity**.

They play key roles in the segregation of lymphoid populations within lymphoid organs

CCL19, CCL21 (produced by reticular fibroblasts) are ligands for the receptor **CCR7**, preferentially expressed by naive T cells

....mature dendritic cells express this receptor too.

CXCL13 (produced by follicular dendritic cells) binds **CXCR5**, a receptor expressed by naive B cells in lymph nodes

La colocalizzazione in aree ricche in chemochine
aumenta la possibilità di incontri tra APC e linfocita T

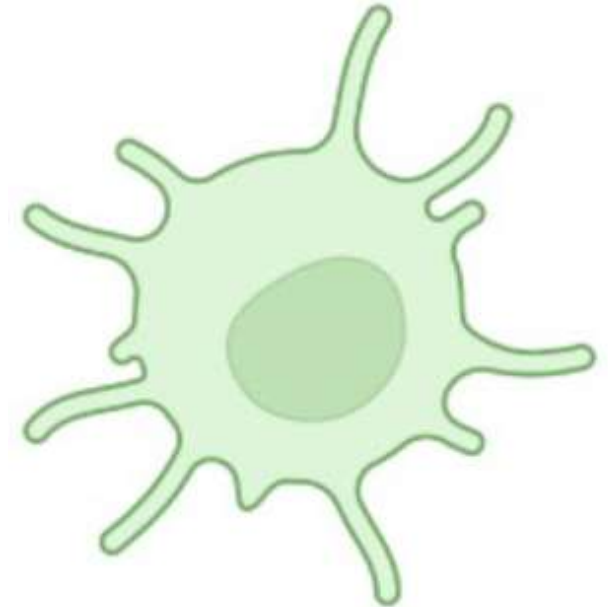
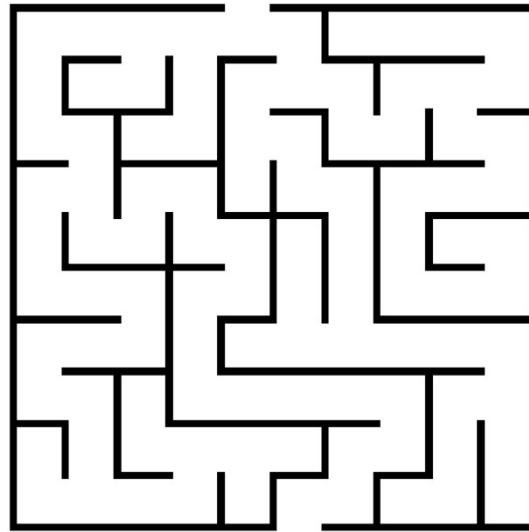

The spleen

... is composed of an external capsule of connective tissue and an internal structure divided into two parts:

Red pulp: containing venous vessels and macrophages and many red blood cells. 1) It eliminates defective red blood cells and remove debris from the blood 2) It is a reservoir of platelets and iron

White pulp: covers a small area where lymphocytes are located

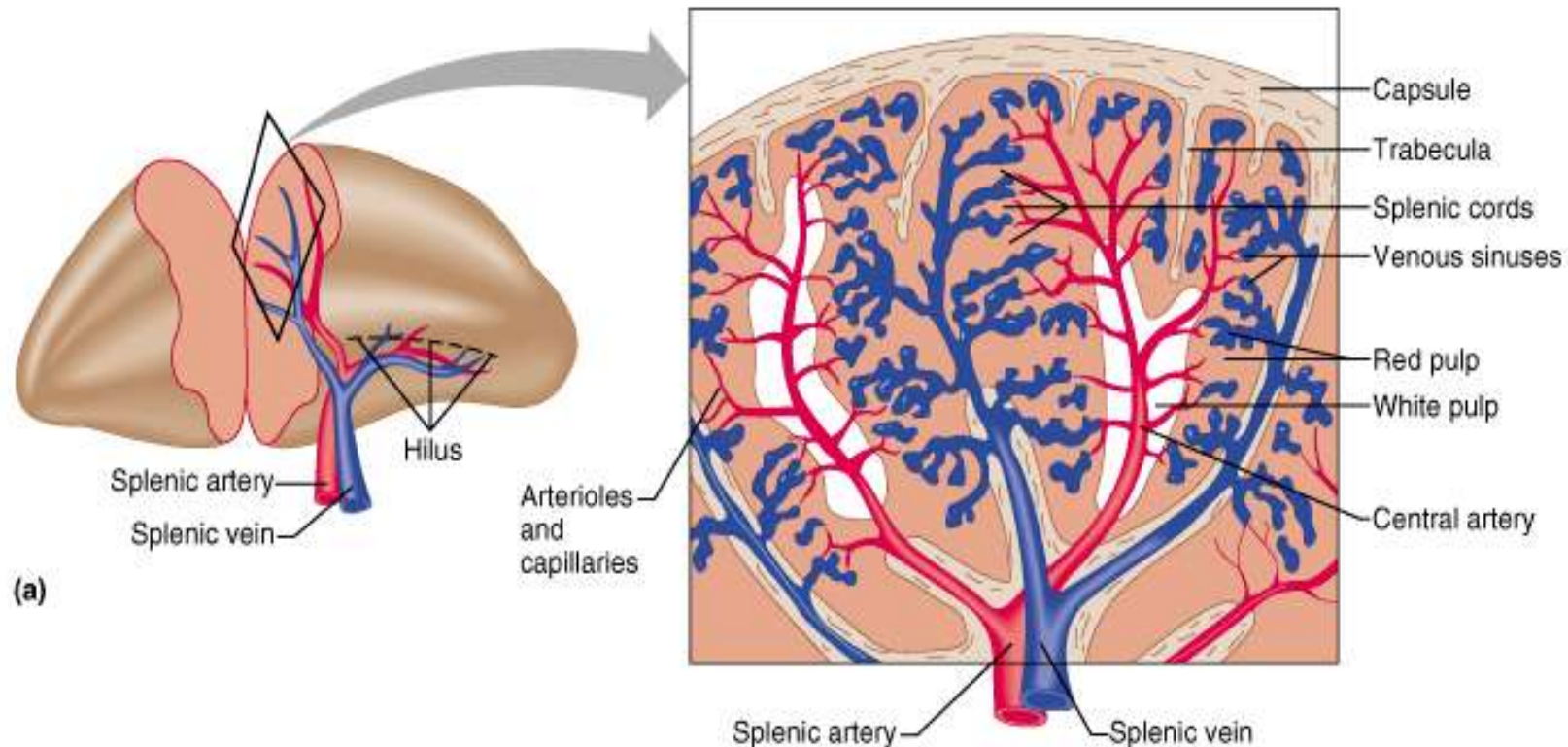

White pulp function: activate the responses to the antigens present in the blood

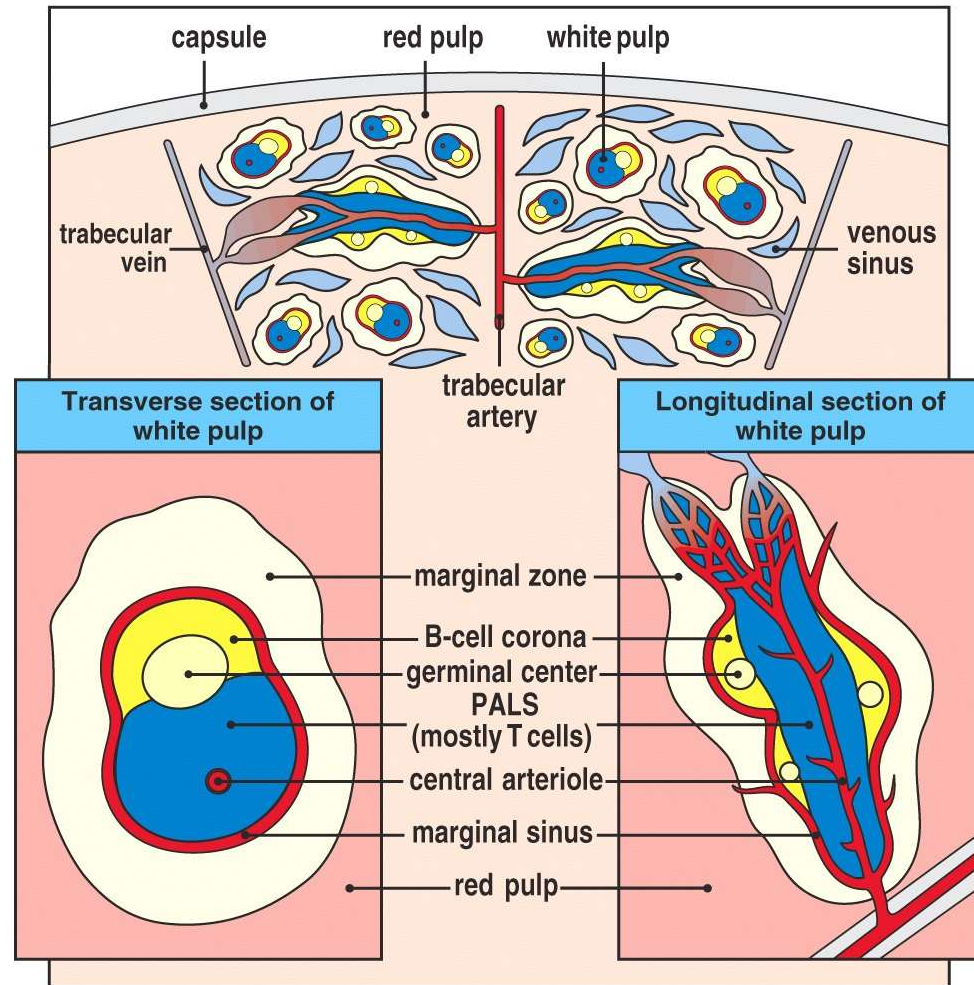

Figure 1-9 part 2 of 3 Immunobiology, 6/e. (© Garland Science 2005)

In the white pulp there is a trabecular artery from which the central arteriole originates (on their sides there are the periarteriolar lymphoid sheaths, called PALS, composed of T lymphocytes).

The B lymphocytes, with germinal centers, form a crown around the periarteriolar area. Specialized B lymphocytes are also present in the marginal area

MALT consists of: lymphocytes located in the epithelial layer or scattered in the lamina propria

In the gut there are also organized structures: the PEYER patches

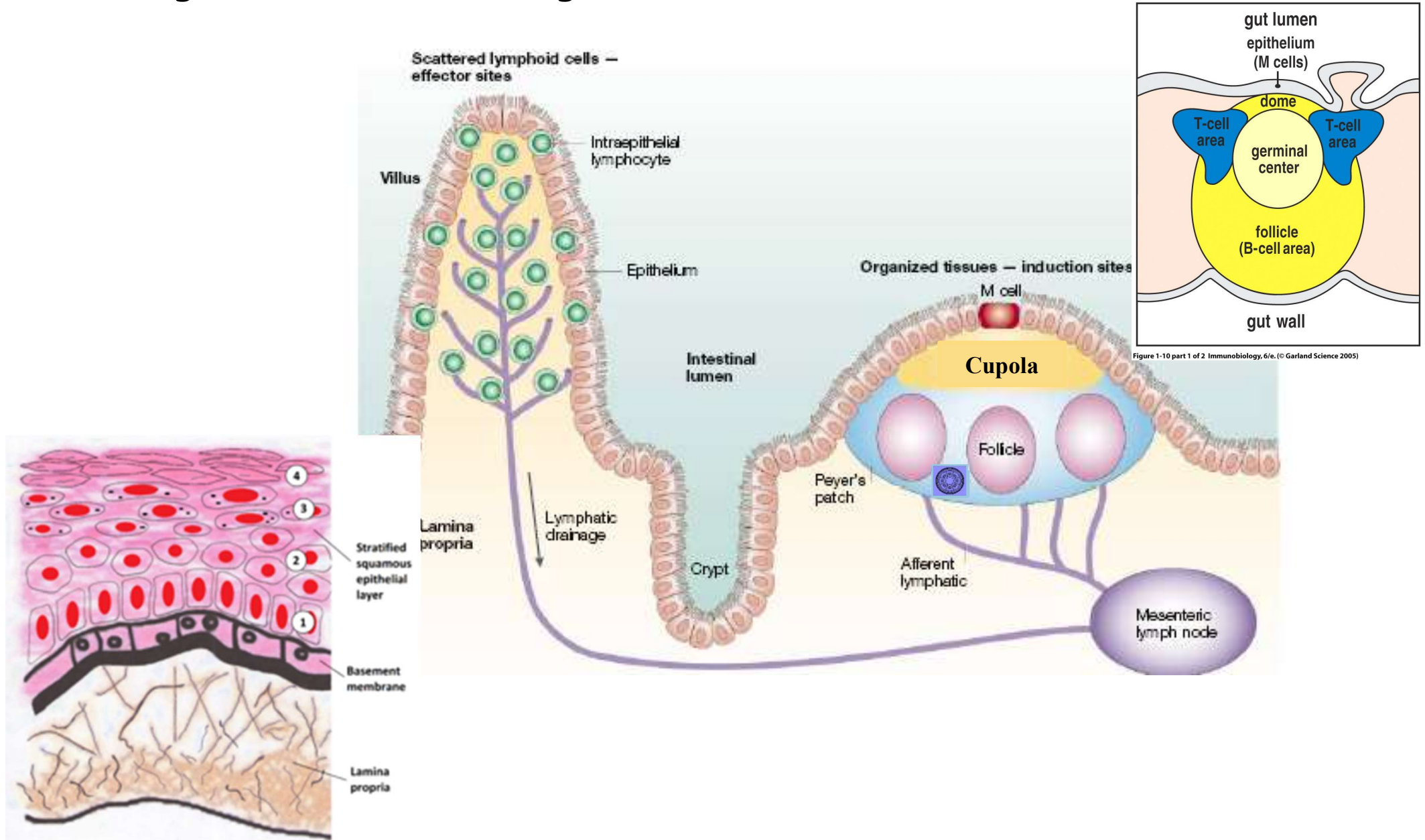

Organizzazione funzionale degli organi linfoidei secondari

	White pulp	Lymphnodes	Peyer Patches
Surveillance	Blood	Lymph	Intestinal content (local)
Antigen scanning zone	Marginal zone	Subcapsular zone	Follicle associated epithelium
T cell area	Periarteriolar lymphoid sheets	Paracortical zone	Interfollicular area
B cell area	Follicles	Cortical or follicular zone	Follicles e corona
Distribution channels	Marginal sinus, conduits	Subcapsular sinus Reticular conduits	?

Ricapitolando....

Che cosa si intende per organo linfoide secondario?

Che cosa è il dotto toracico?

Dove si trovano le cellule follicolari dendritiche?

Che funzione svolge la polpa bianca della milza?

Come si mantiene la divisione spaziale tra linfociti T e B negli organi linfoidi secondari?

Che ruolo hanno i vasi linfatici nella regolazione del traffico linfocitario?

Come fanno i leucociti circolanti ad entrare nei tessuti?

Multistep paradigm of transendothelial migration

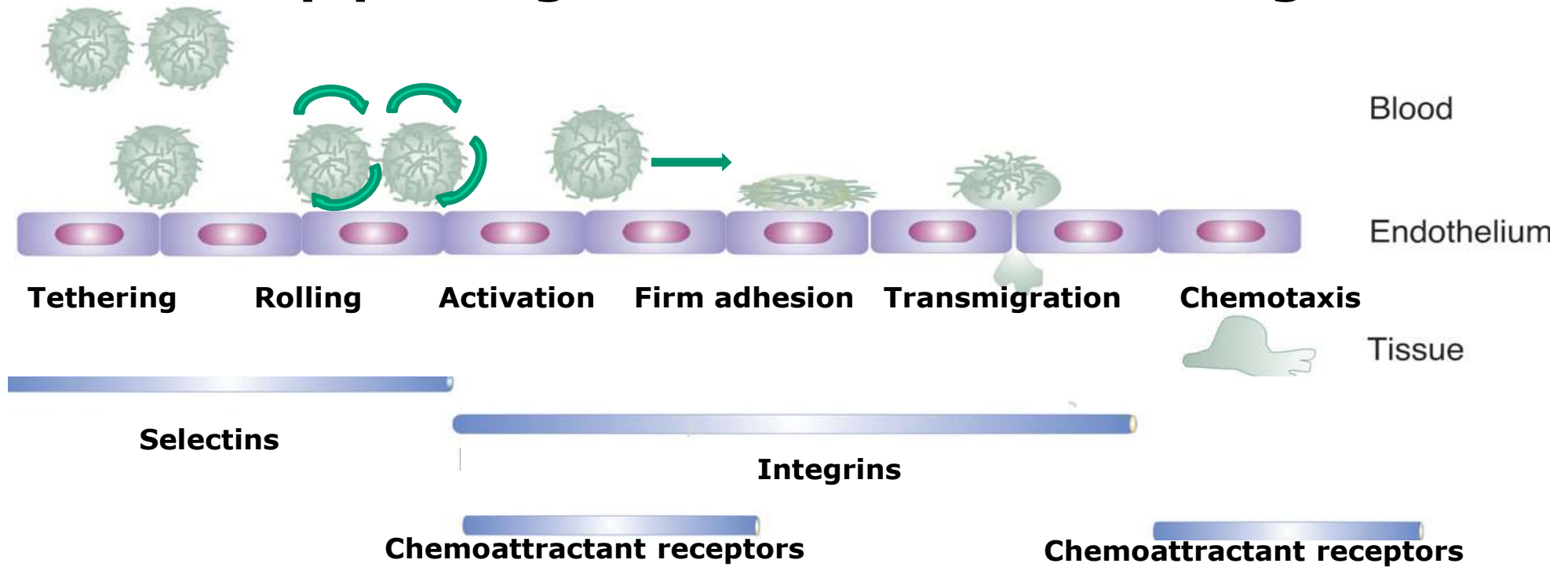

The role of migration in the immune system

- During maturation and differentiation
- In the immune surveillance that depends on constitutive and tissue-specific (or inducible) homing
- Inflammatory process regulation

The role of migration in the immune system

- During maturation and differentiation
- In the immune surveillance that depends on constitutive and tissue-specific (or inducible) homing
- **Inflammatory process regulation**

A fundamental event for leukocyte function is the passage from the bloodstream to the tissues (extravasation)

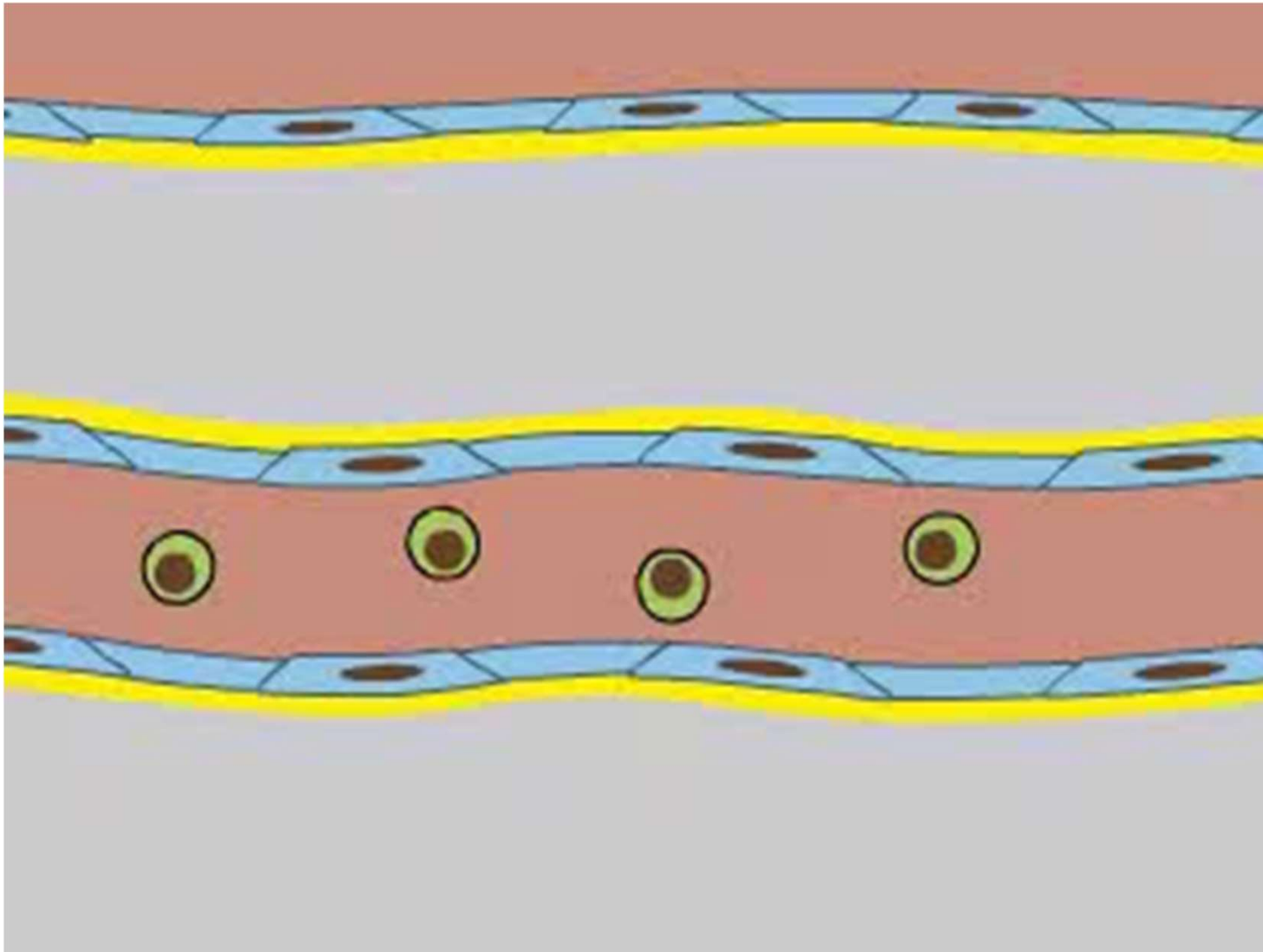

Migrazione transendoteliale dei neutrofili durante l'infiammazione

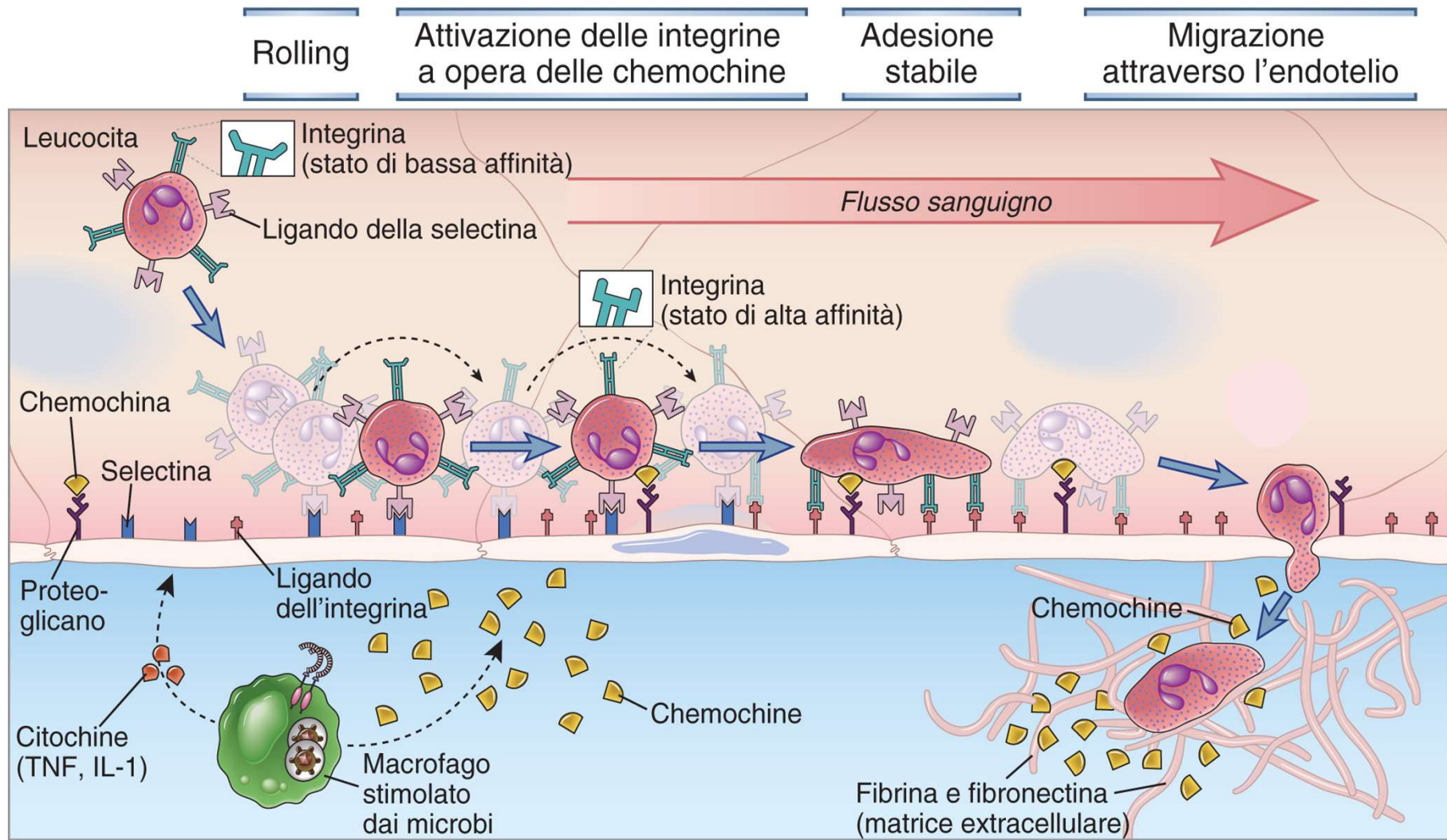

The role of migration in the immune system

- During maturation and differentiation
- **In the immune surveillance that depends on constitutive and tissue-specific (or inducible) homing**
- Inflammatory process regulation

HOMING

(lymphocyte localization):

Selective migration of functionally distinct lymphocyte populations in specific body districts:

1-lymphoid organs (**constitutive homing**)

2-sites of infection/inflammation (**inducible homing**)

Lymphocytes differ from most leucocytes (which only cross the blood to participate in the inflammatory response in terminal destinations) because they **recirculate** from the blood to the lymph.

Lymphocyte recirculation

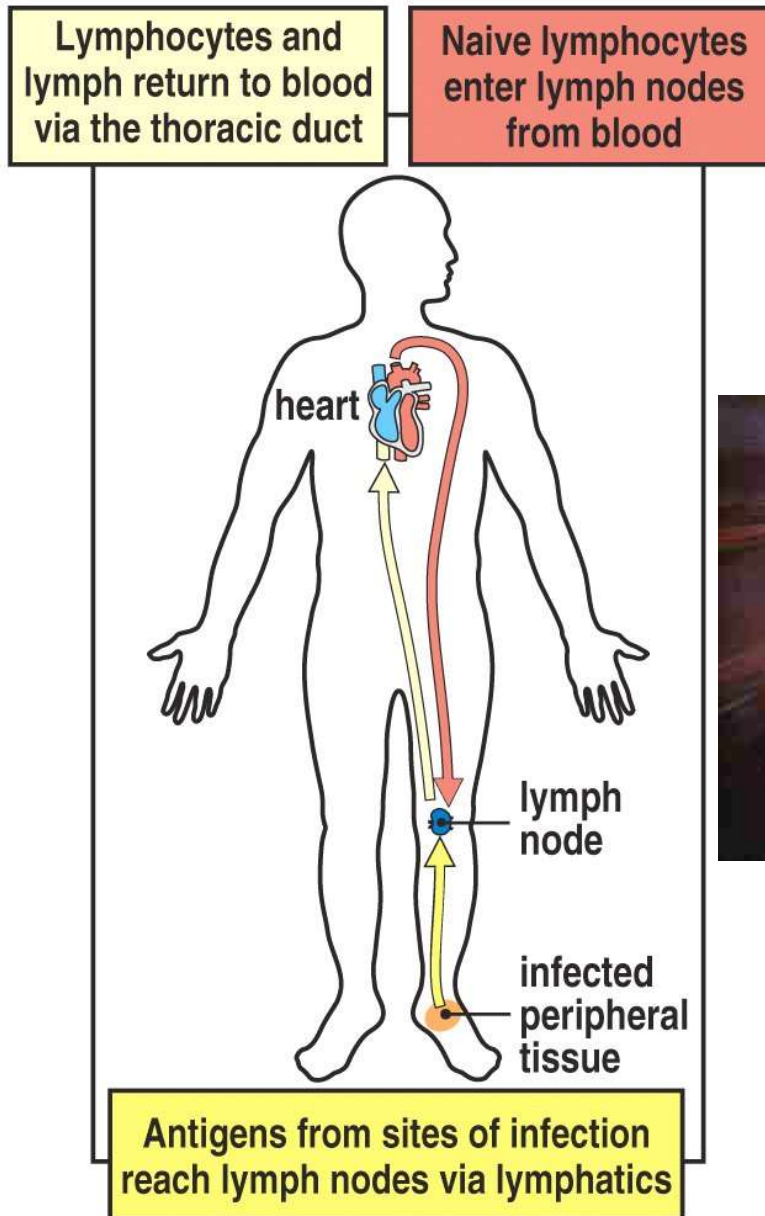
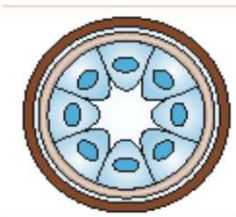
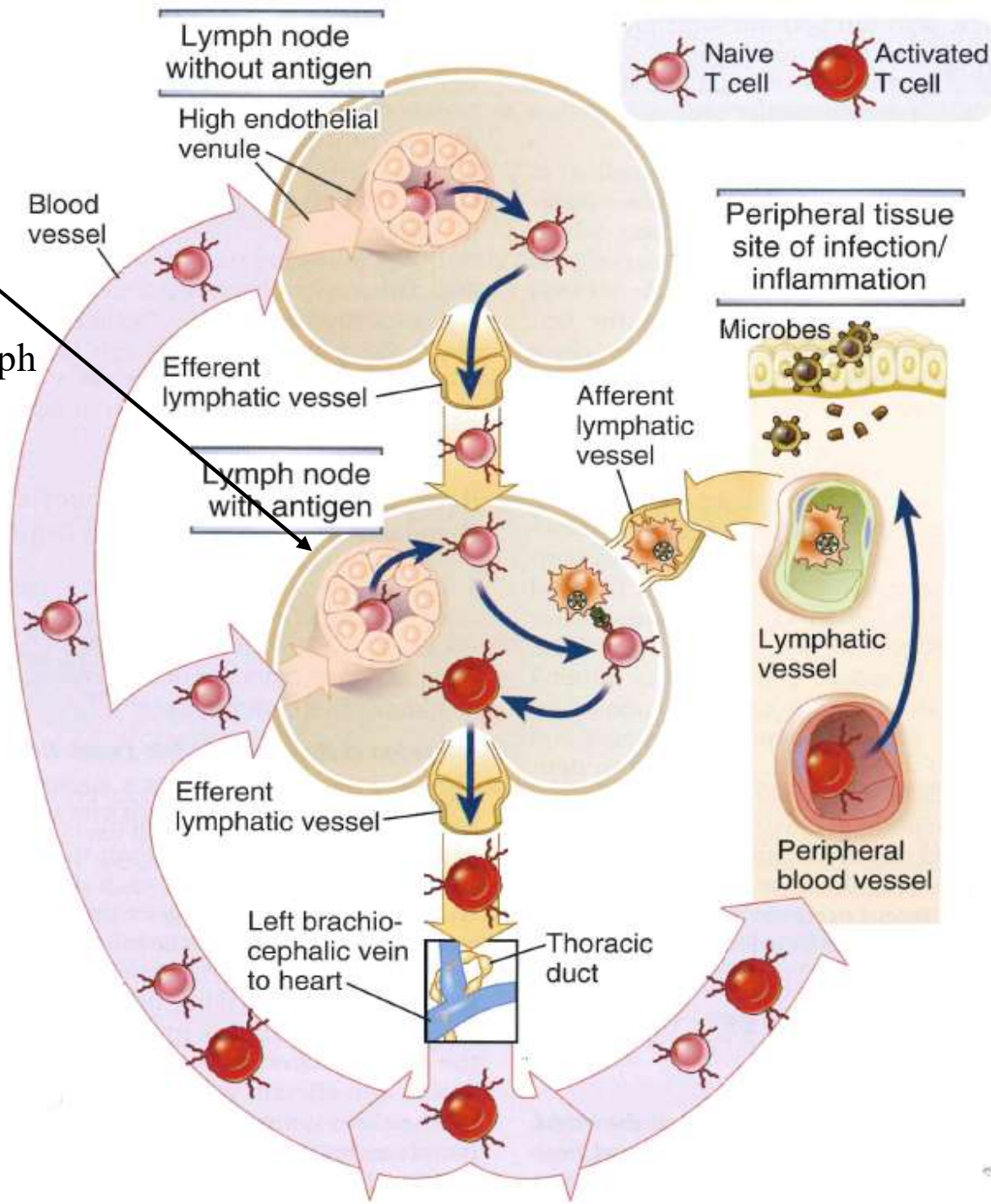

Figure 1-11 Immunobiology, 6/e. (© Garland Science 2005)

T lymphocyte recirculation



High endothelial venules (HEV) are located in lymph node and Peyer patches but not in spleen



The molecules expressed on the membrane of the lymphocytes responsible for the recirculation process are called Homing Receptors

The molecules expressed on the endothelium are called Addressins.

How is the site of extravasation targeted so precisely?



Come si può dimostrare il contributo di determinate molecole nella migrazione transendoteliale di specifici leucociti ?

SAGGIO DI MIGRAZIONE SOTTO FLUSSO

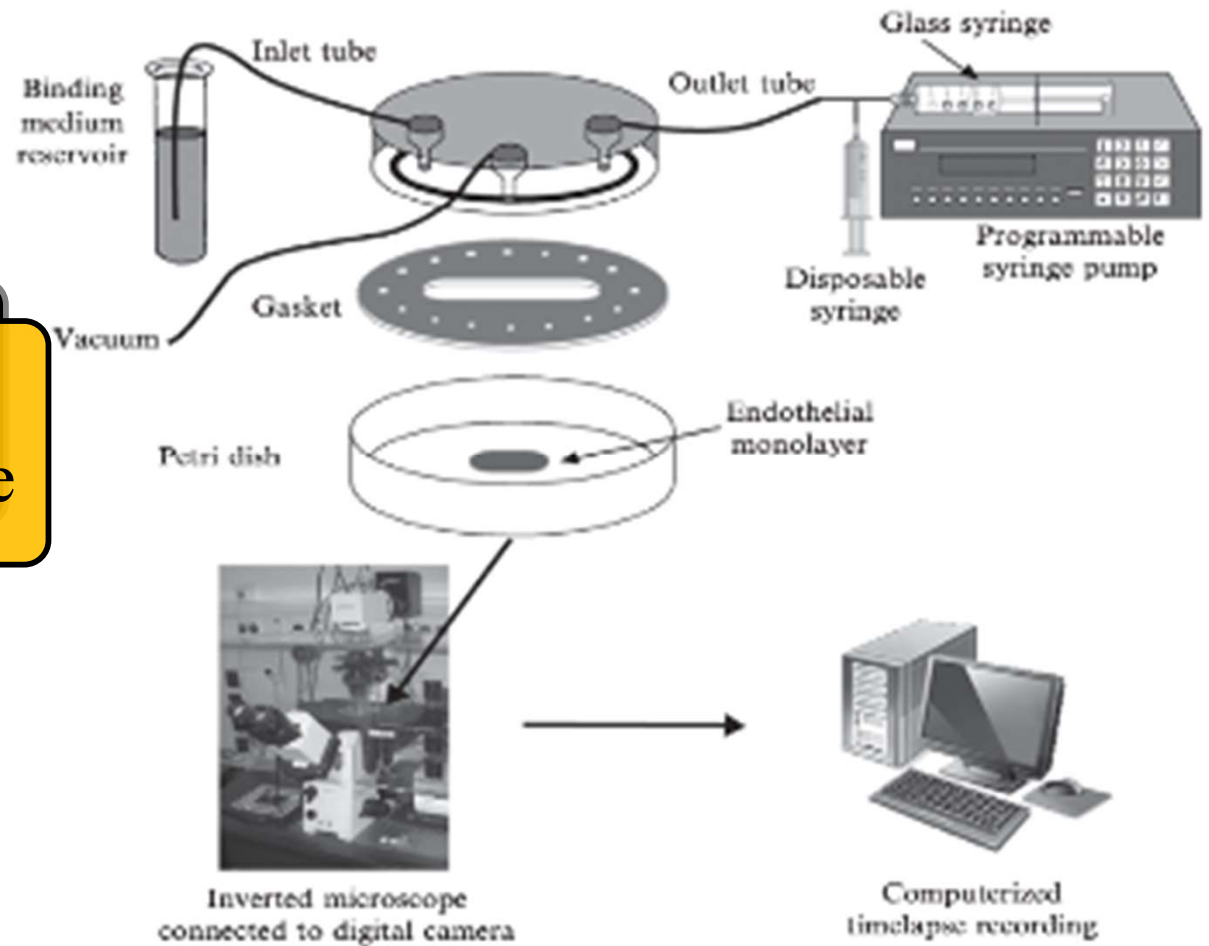
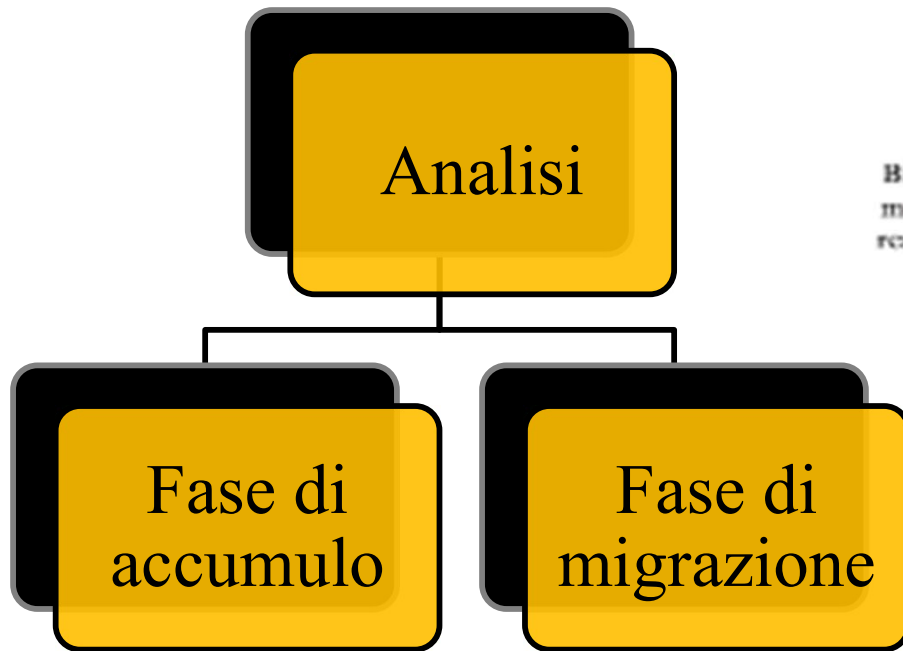

SAGGIO DI MIGRAZIONE SOTTO FLUSSO

Migrazione dei linfociti attraverso l'endotelio vascolare che espone chemochine apicali

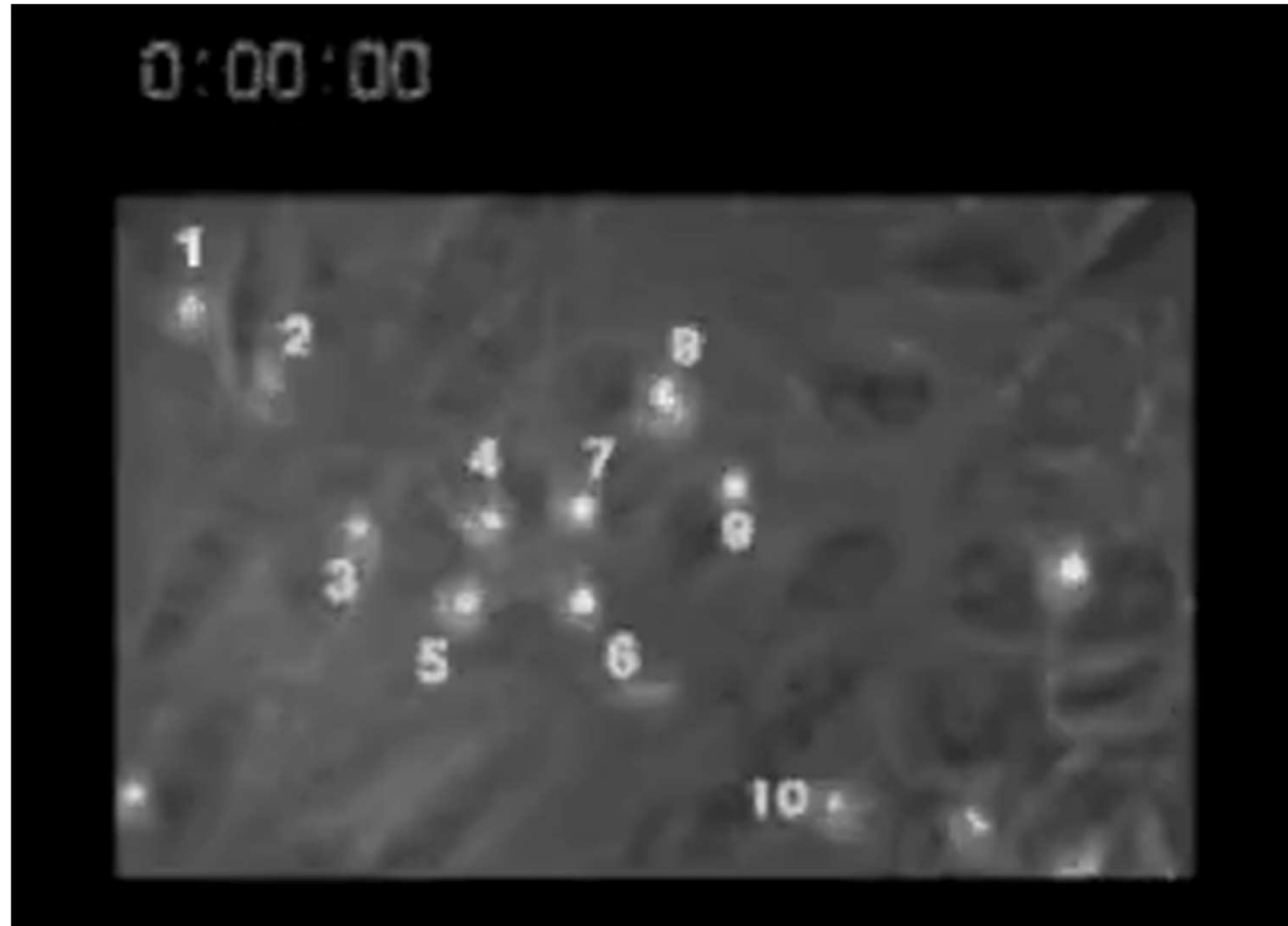

Cinamon et al., Nature Immunology, 2001

Migration of leukocyte through endothelium depends on:

- speed of blood flux
- endothelial cell surface electric charge
- **adhesion molecules**
- **chemotactic factors**
- **Cytokines**

Intercellular adhesion molecules

The intercellular adhesion molecules are membrane molecules that allow:

Adaptive lymphocyte migration into tissues and secondary lymphoid organs (recirculation and homing)

Leukocyte migration to the area of infection

Interaction of T and B lymphocytes with each other and with other cells involved in the immune response

Selectins are membrane glycoproteins, members of the family of Ca^{2+} dependent C-type lectin receptors

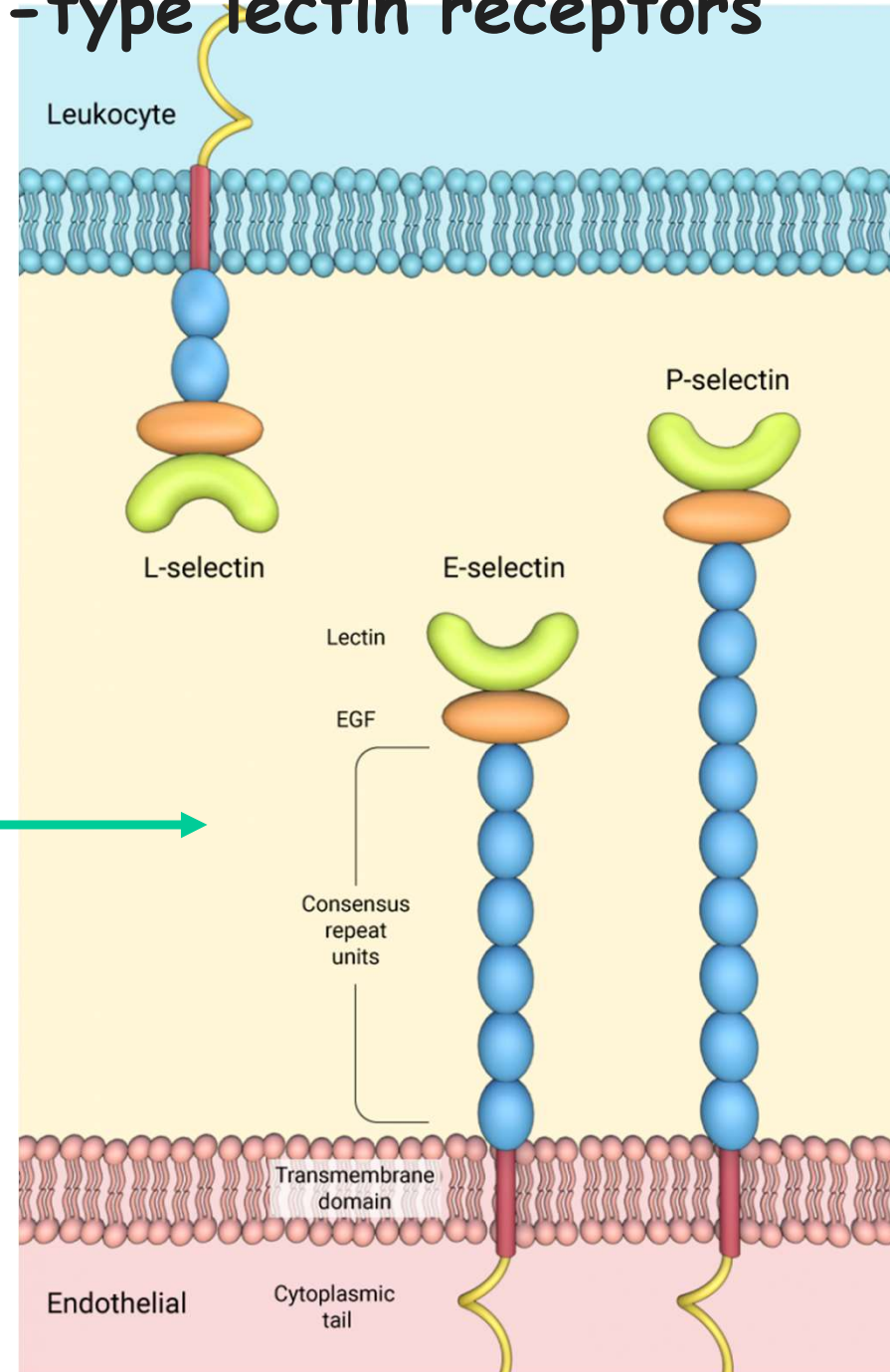

CCP= domini omologhi a quelli presenti nelle proteine regolatorie del complemento

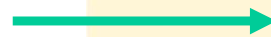

Low affinity interactions, $100 \mu\text{M}$

Selectin ligands

They are membrane mucin-like proteins highly glycosylated

Sialyl-Lewis X (sLeX) is the main recognized carbohydrate and is presented by glycoproteins

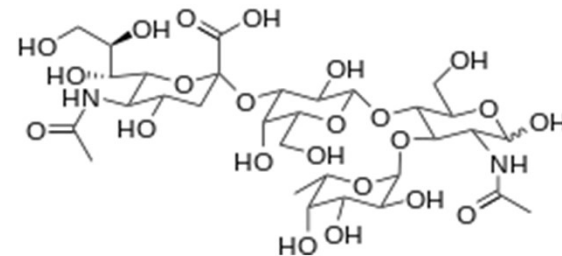

Homing of naïve T cells

L-selectin and vascular addressins

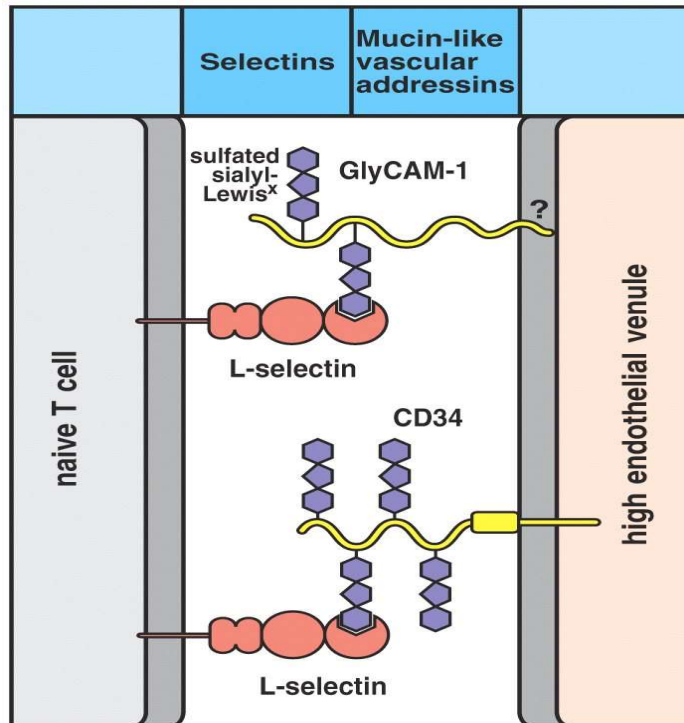

Figure 8-5 part 1 of 2 Immunobiology, 6/e. (© Garland Science 2005)

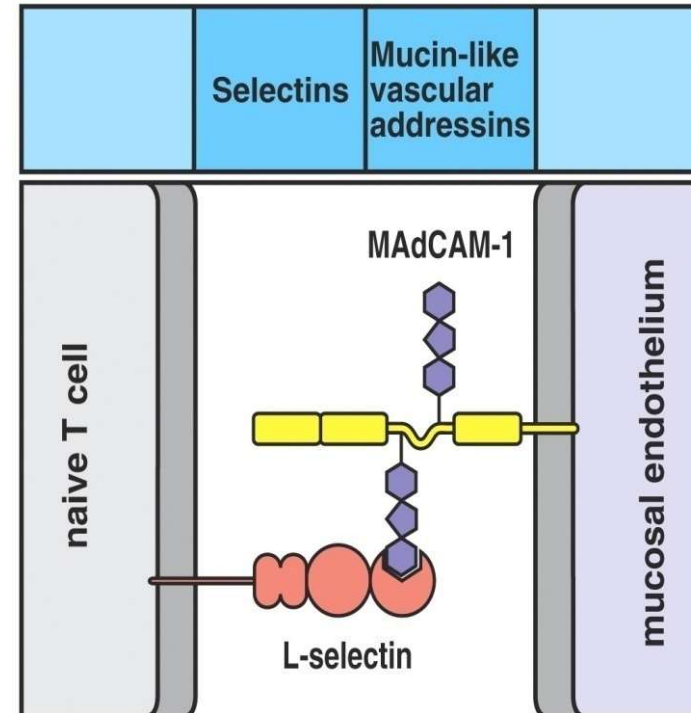

Figure 8-5 part 2 of 2 Immunobiology, 6/e. (© Garland Science 2005)

GlyCAM-1 (glycosylation-dependent cell adhesion molecule 1) e **CD34**, sono espresse a bassi livelli dagli endoteli ma sono espresse sulle HEV dei linfonodi e legano la **L-selectina**

MadCAM-1: Mucosal addressin Cell Adesion Molecule-1

Homing of effector/memory T cells

E- e P-Selectin Ligands = Addressins

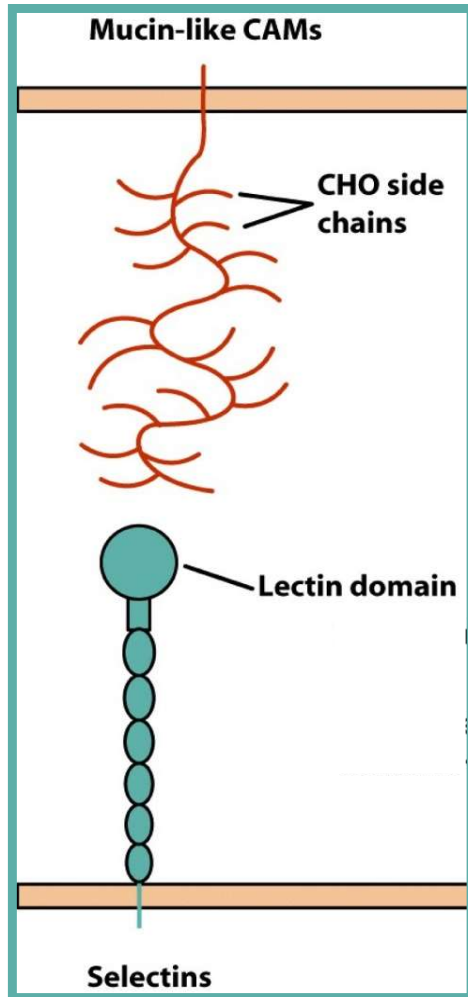

Name	Tissue distribution	Ligand
P-selectin (PADGEM, CD62P)	Activated endothelium and platelets	PSGL-1, sialyl-Lewis ^x
E-selectin (ELAM-1, CD62E)	Activated endothelium	Sialyl-Lewis ^x

PSGL1= P-selectin glycoprotein ligand 1. Expressed on all leukocytes.

Sialyl-Lewis X (sLeX) is the main carbohydrate recognized. It is found on numerous surface proteins expressed by granulocytes, monocytes and memory T cells.

What is the contribution of selectins to transendothelial migration in secondary lymphoid organs?

1. Contact with endothelium and cell rolling

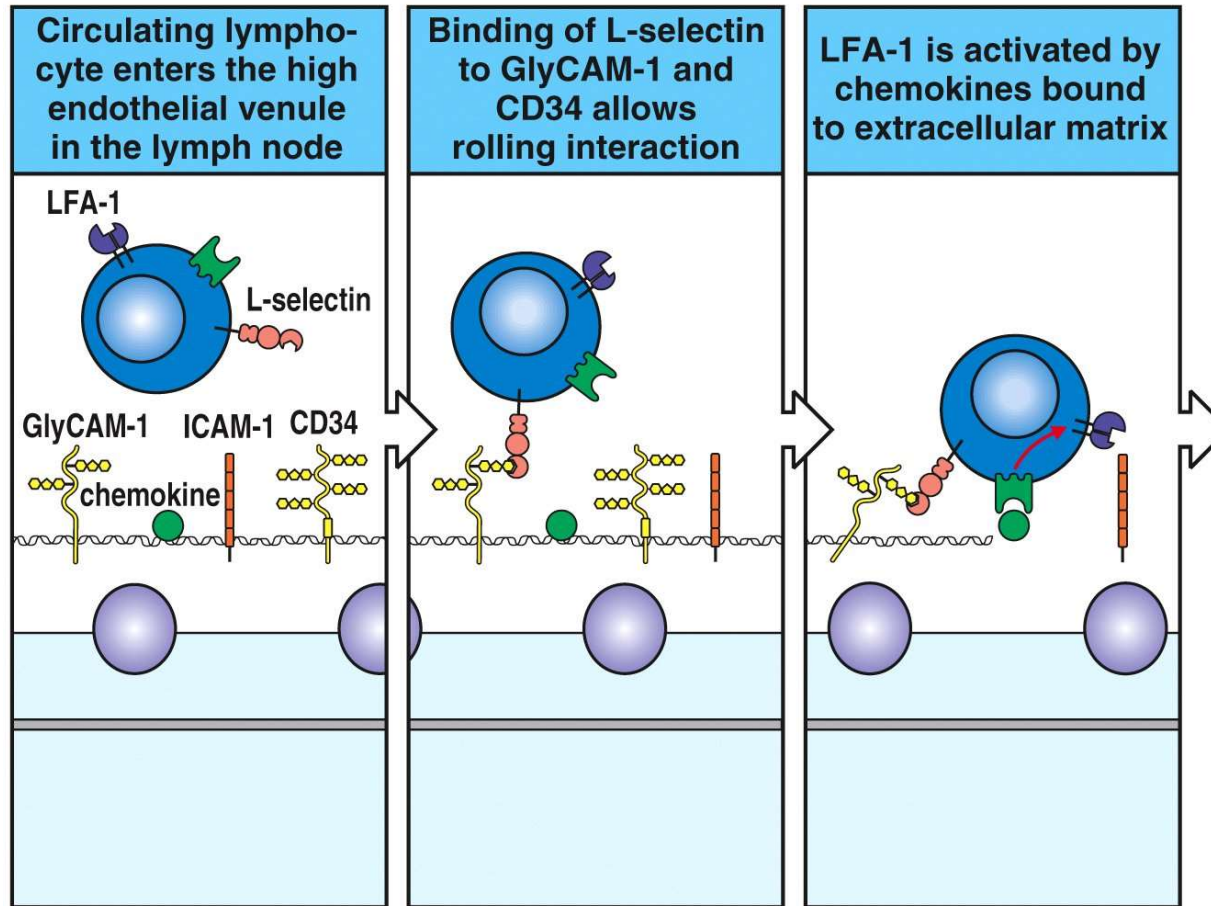
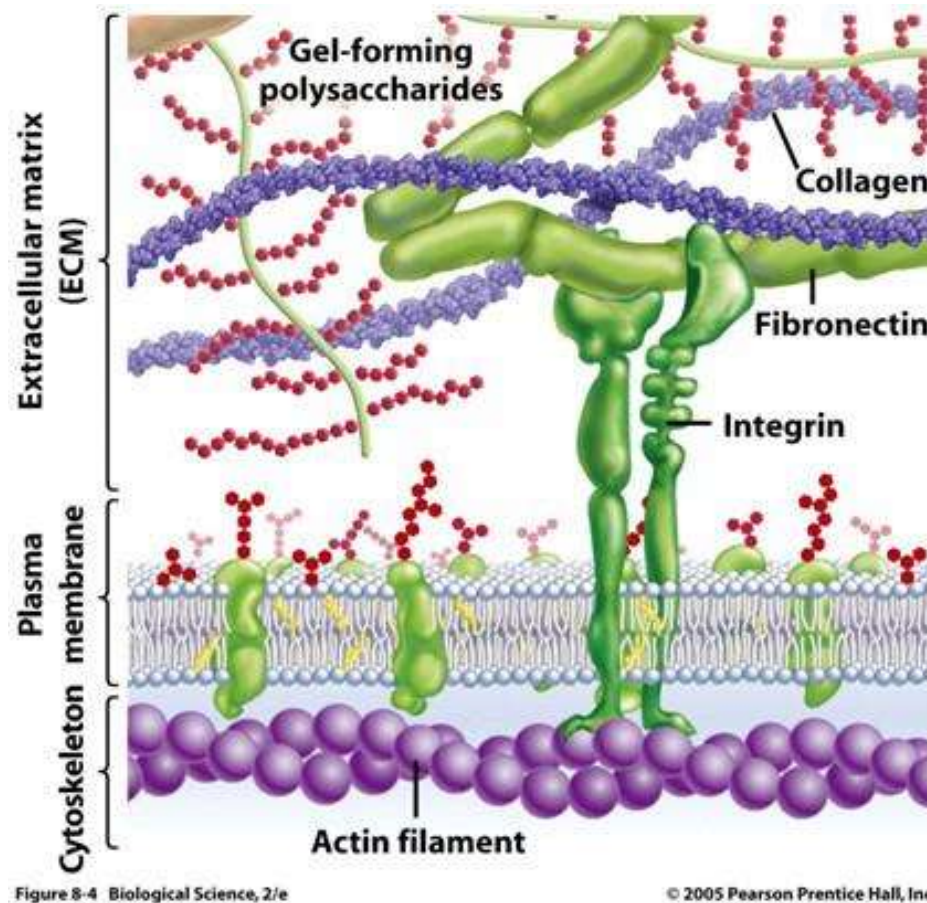

Figure 10-7 part 1 of 2 Immunobiology, 6/e. (© Garland Science 2005)

2. Adhesion and transendothelial migration

Integrins



Various subfamilies according to the beta-chain subunits

a large family of heterodimeric transmembrane glycoproteins that attach cells to extracellular matrix proteins of the basement membrane or to ligands on other cells

Structure and affinity/avidity changes for ligands of leukocyte integrins

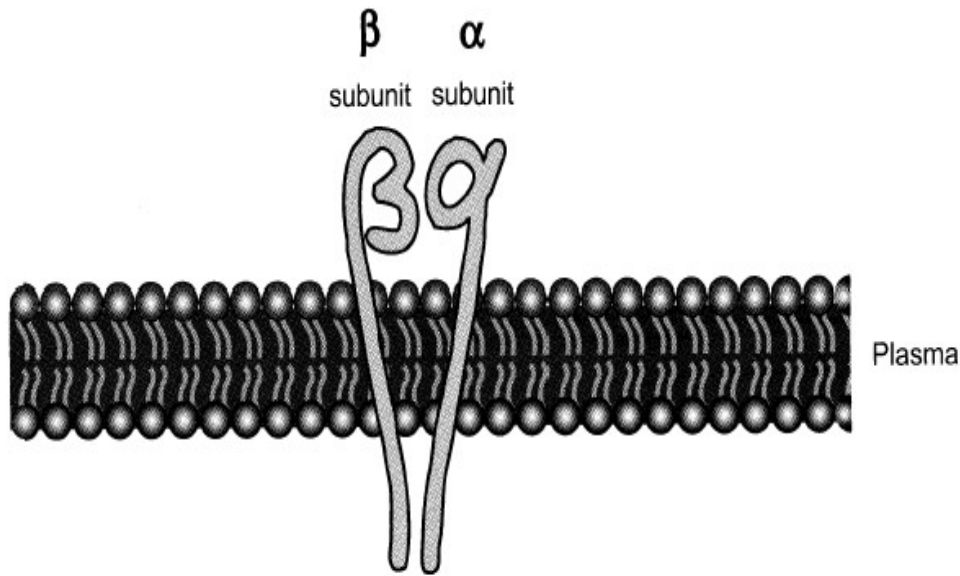
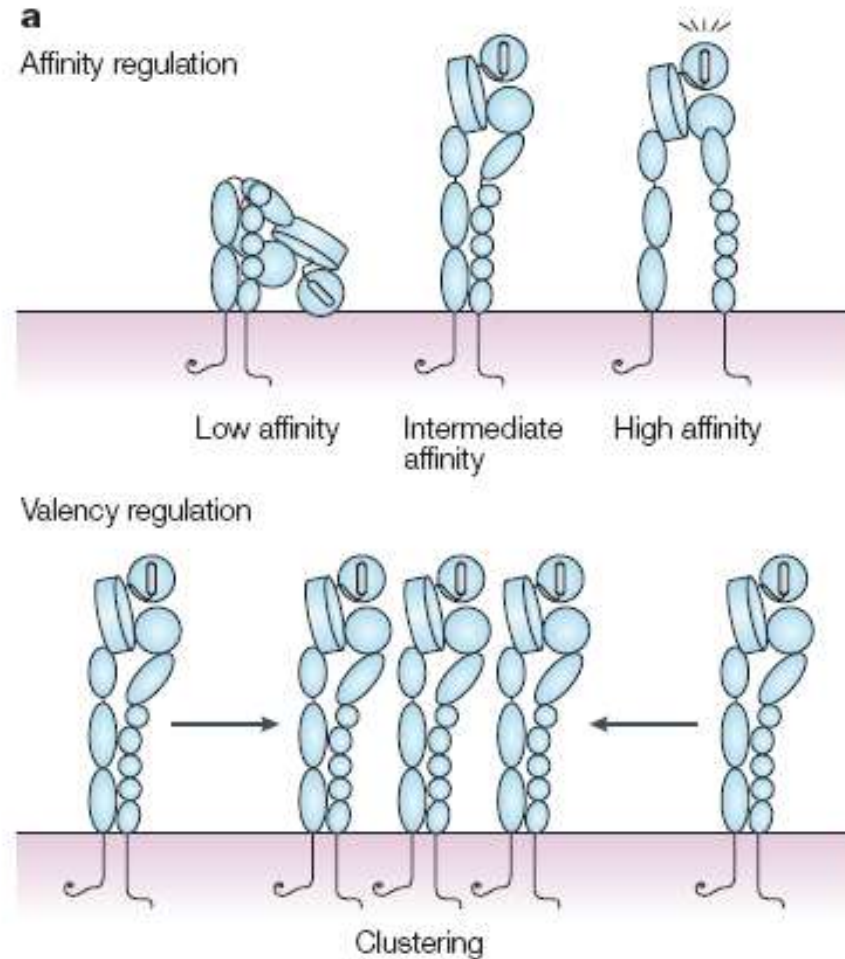
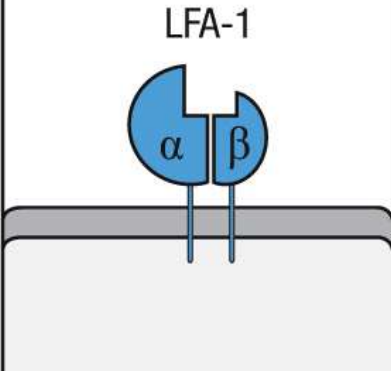

Figure 2. Schematic diagram of integrin heterodimer.



Integrins contain large (α) and small (β) subunits of sizes 120-170 kDa and 90-100 kDa, respectively.

Integrins of beta-2 subfamily and their ligands

		Name	Tissue distribution	Ligand
Integrins Bind to cell-adhesion molecules and extracellular matrix. Strong adhesion	 <p>The diagram shows a cross-section of a cell membrane. On the surface, there is a blue Y-shaped structure labeled 'LFA-1'. It consists of two subunits, alpha (α) and beta (β), which are joined together. The alpha subunit is on the left and the beta subunit is on the right. Both subunits have short stalks extending into the cytoplasm of the cell.</p>	$\alpha_L:\beta_2$ (LFA-1, CD11a:CD18)	Monocytes, T cells, macrophages, neutrophils, dendritic cells, NK cells	ICAM-1, ICAM-2
		$\alpha_M:\beta_2$ (CR3, Mac-1, CD11b:CD18)	Neutrophils, monocytes, macrophages, NK cells	ICAM-1, iC3b, fibrinogen
		$\alpha_X:\beta_2$ (CR4, p150.95, CD11c:CD18)	Dendritic cells, macrophages, neutrophils, NK cells	iC3b

Beta-1 integrin subfamily and their ligands

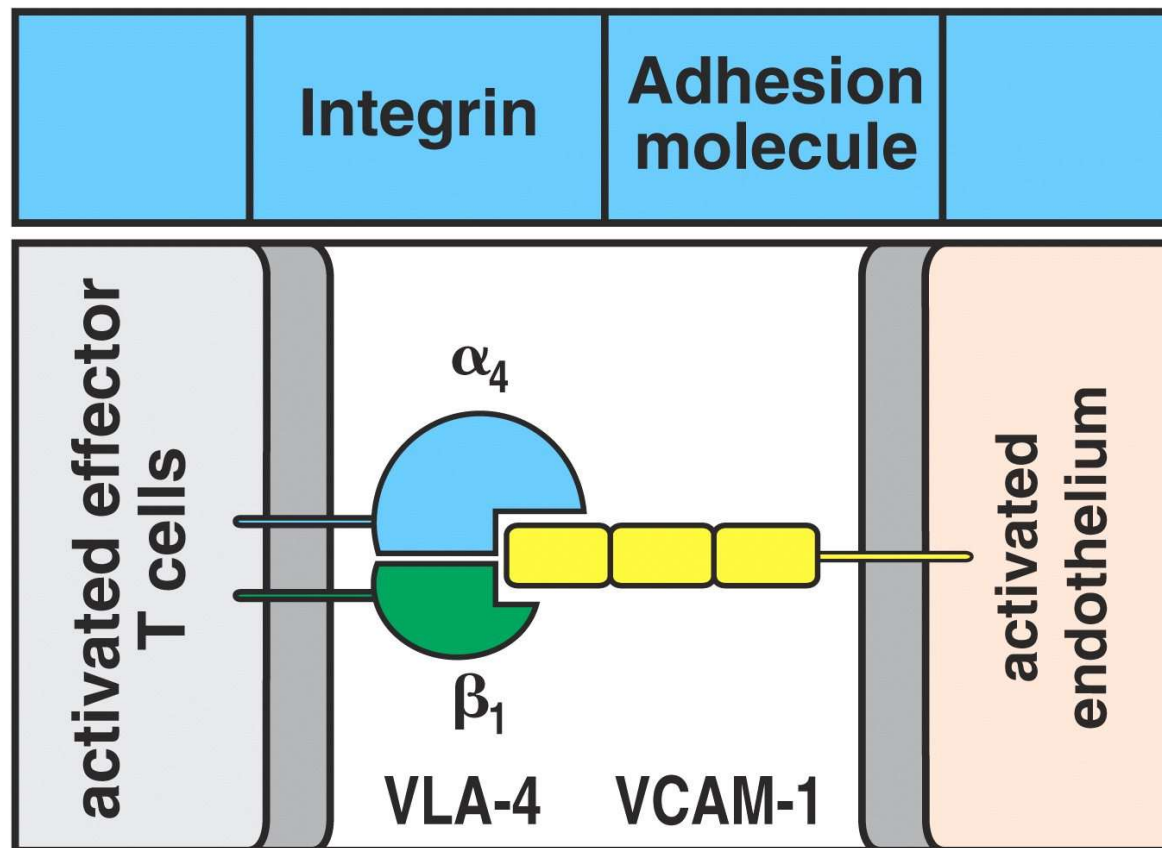

Figure 8-6 part 3 of 3 Immunobiology, 6/e. (© Garland Science 2005)

Il membro più importante della sottofamiglia delle integrine beta-1 sui leucociti è **Very Late Antigen-4, VLA-4**. VLA-4 lega il suo ligando **Vascular Cell Adhesion Molecule- 1 o la Fibronettina. VCAM-1** ed è primariamente responsabile dell'adesione linfocitaria all'endotelio vascolare e del loro richiamo nei tessuti.

Integrin ligands involved in transendothelial migration are adhesion molecules belonging to the superfamily of immunoglobulins

		Name	Tissue distribution	Ligand
Immunoglobulin superfamily		ICAM-1 (CD54)	Activated endothelium, activated leukocytes	LFA-1, Mac1
Various roles in cell adhesion. Ligand for integrins		ICAM-2 (CD102)	Resting endothelium, dendritic cells	LFA-1
		VCAM-1 (CD106)	Activated endothelium	VLA-4
		PECAM (CD31)	Activated leukocytes, endothelial cell-cell junctions	CD31

Figure 3.29 (part 3 of 3) Janeway's Immunobiology, 9th ed. (© Garland Science 2017)

Main families of adhesion molecules involved in leukocyte extravasation

(a) Struttura generale delle famiglie CAM

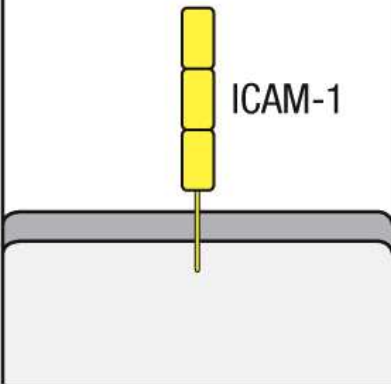
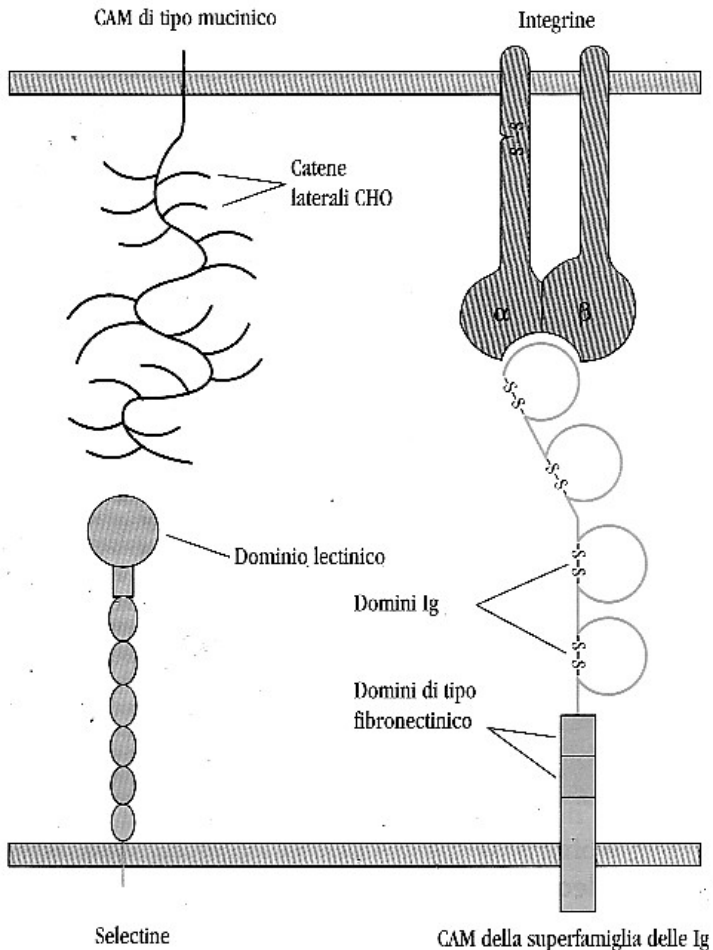

TABLE 3.1 Major Leukocyte-Endothelial Adhesion Molecules

Family	Molecule	Distribution	Ligand (Molecule; Cell Type)
Selectin	P-selectin (CD62P)	Endothelium activated by histamine or thrombin	Sialyl Lewis X on PSGL-1 and other glycoproteins; neutrophils, monocytes, T cells (effector, memory)
	E-selectin (CD62E)	Endothelium activated by cytokines (TNF, IL-1)	Sialyl Lewis X (e.g., CLA-1) on glycoproteins; neutrophils, monocytes, T cells (effector, memory)
	L-selectin (CD62L)	Neutrophils, monocytes, T cells (naive and central memory), B cells (naive)	Sialyl Lewis X/PNAd on GlyCAM-1, CD34, MadCAM-1, others; endothelium (HEV)
Integrin	LFA-1 (CD11aCD18)	Neutrophils, monocytes, T cells (naive, effector, memory), B cells (naive)	ICAM-1 (CD54), ICAM-2 (CD102); endothelium (upregulated when cytokine activated)
	Mac-1 (CD11bCD18)	Neutrophils, monocytes, dendritic cells	ICAM-1 (CD54), ICAM-2 (CD102); endothelium (upregulated when cytokine activated)
	VLA-4 (CD49aCD29)	Monocytes, T cells (naive, effector, memory)	VCAM-1 (CD106); endothelium (upregulated when cytokine activated)
	$\alpha_4\beta_7$ (CD49dCD29)	Monocytes, T cells (gut homing, naive, effector, memory), B cells (gut homing)	VCAM-1 (CD106), MadCAM-1; endothelium in gut and gut-associated lymphoid tissues

CLA-1, Cutaneous lymphocyte antigen 1; GlyCAM-1, glycan-bearing cell adhesion molecule 1; HEV, high endothelial venule; ICAM-1, intracellular adhesion molecule 1; IL-1, interleukin-1; LFA-1, leukocyte function-associated antigen 1; MadCAM-1, mucosal addressin cell adhesion molecule 1; PNAd, peripheral node addressin; PSGL-1, P-selectin glycoprotein ligand 1; TNF, tumor necrosis factor; VCAM-1, vascular cell adhesion molecule 1; VLA-4, very late antigen 4.

Why integrins do not constitutively promote adhesion strengthening on the endothelium layer?

Finding the perfect couple (ligand/receptor) affinity!

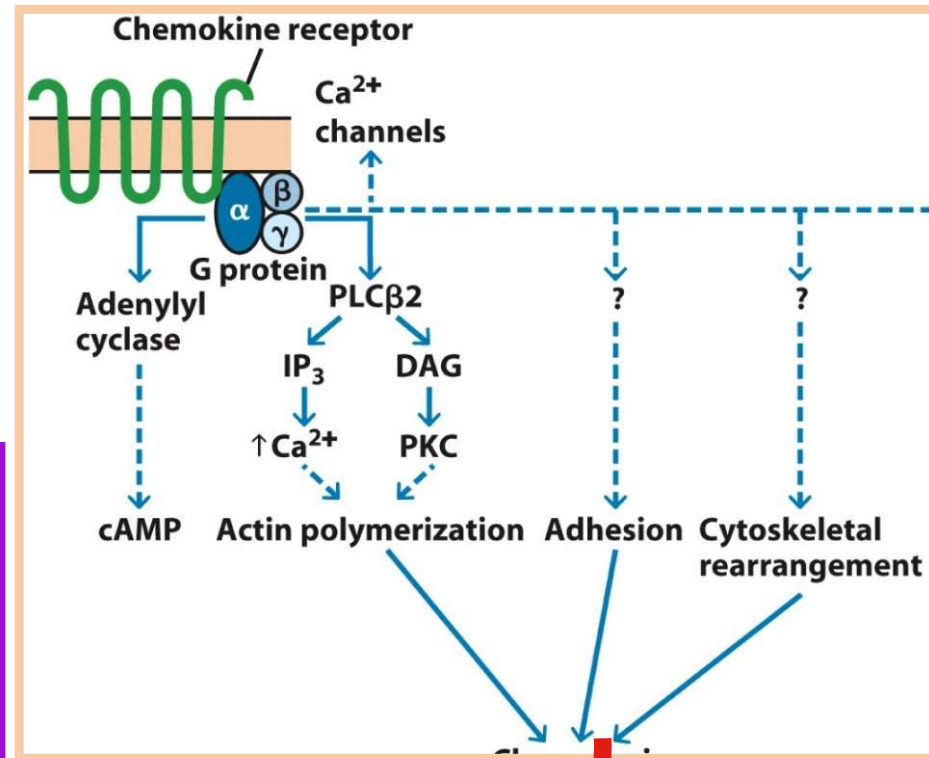
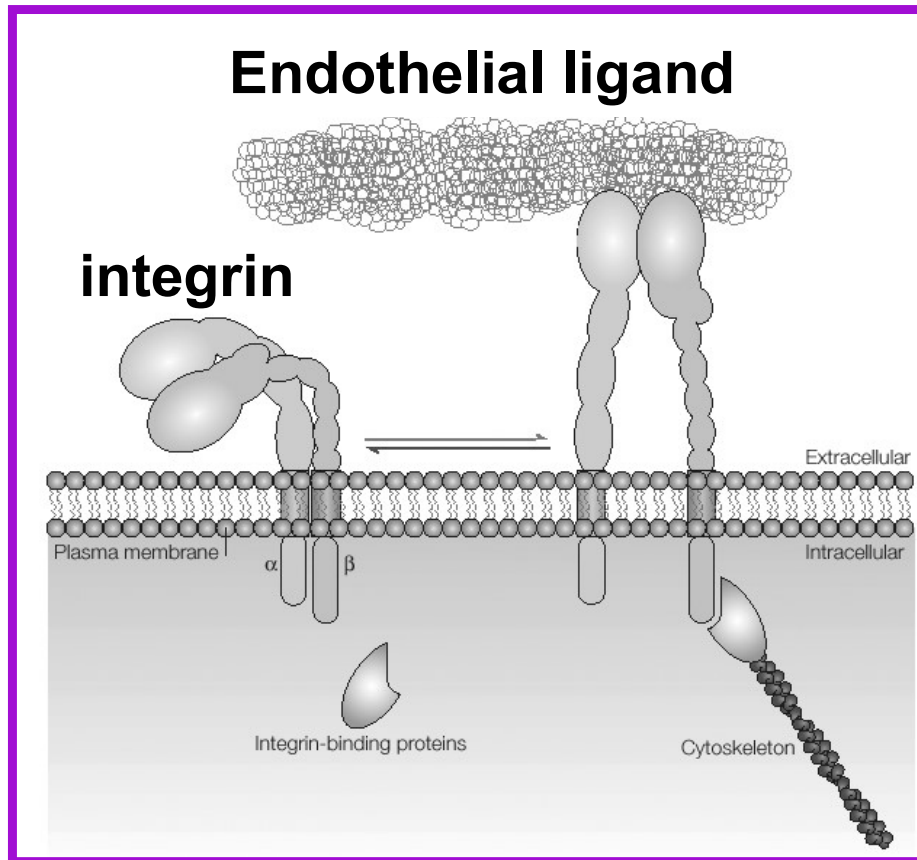

inside-out signalling

Signaling events initiated by chemokine receptor triggering converts integrin conformation into high affinity/avidity state

Transendothelial migration occurs on high endothelial venules (HEV)

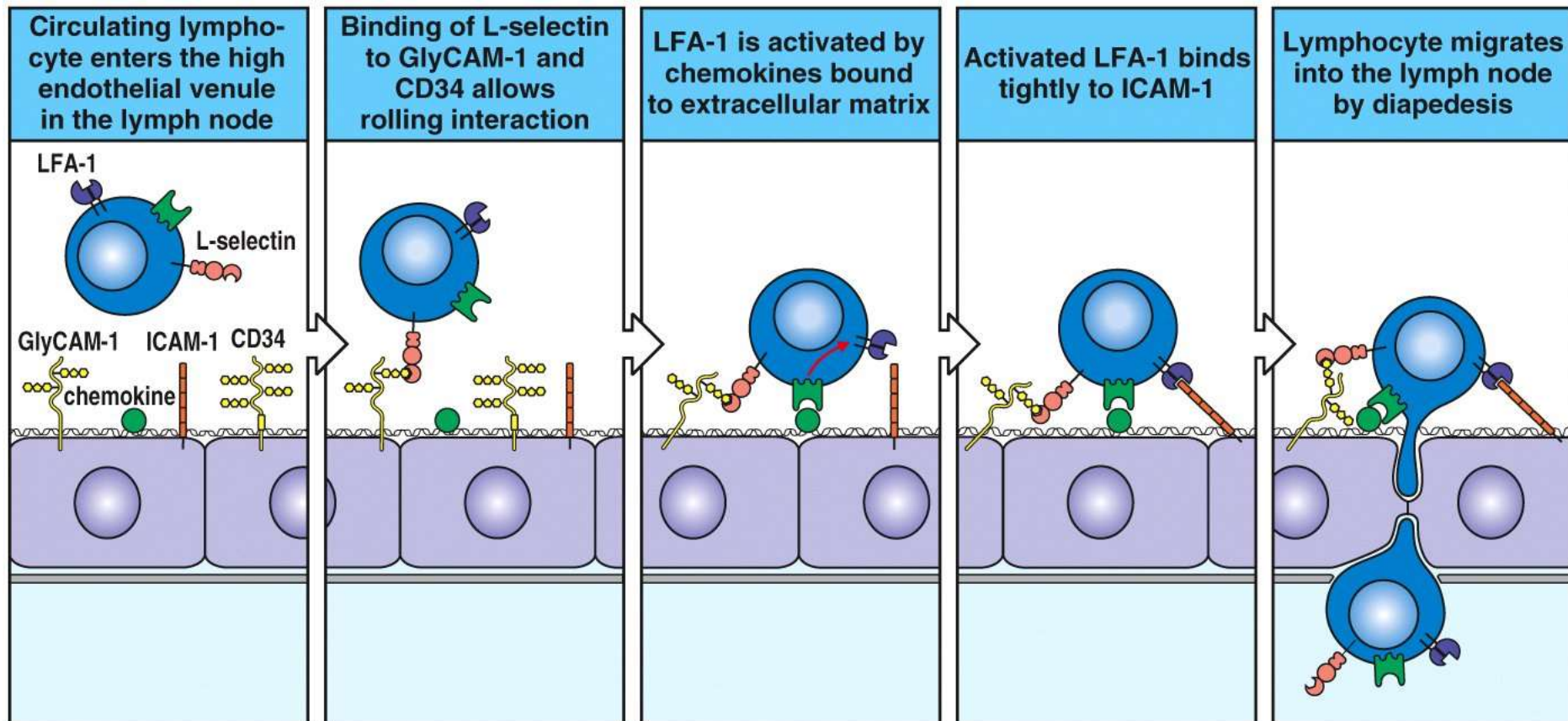
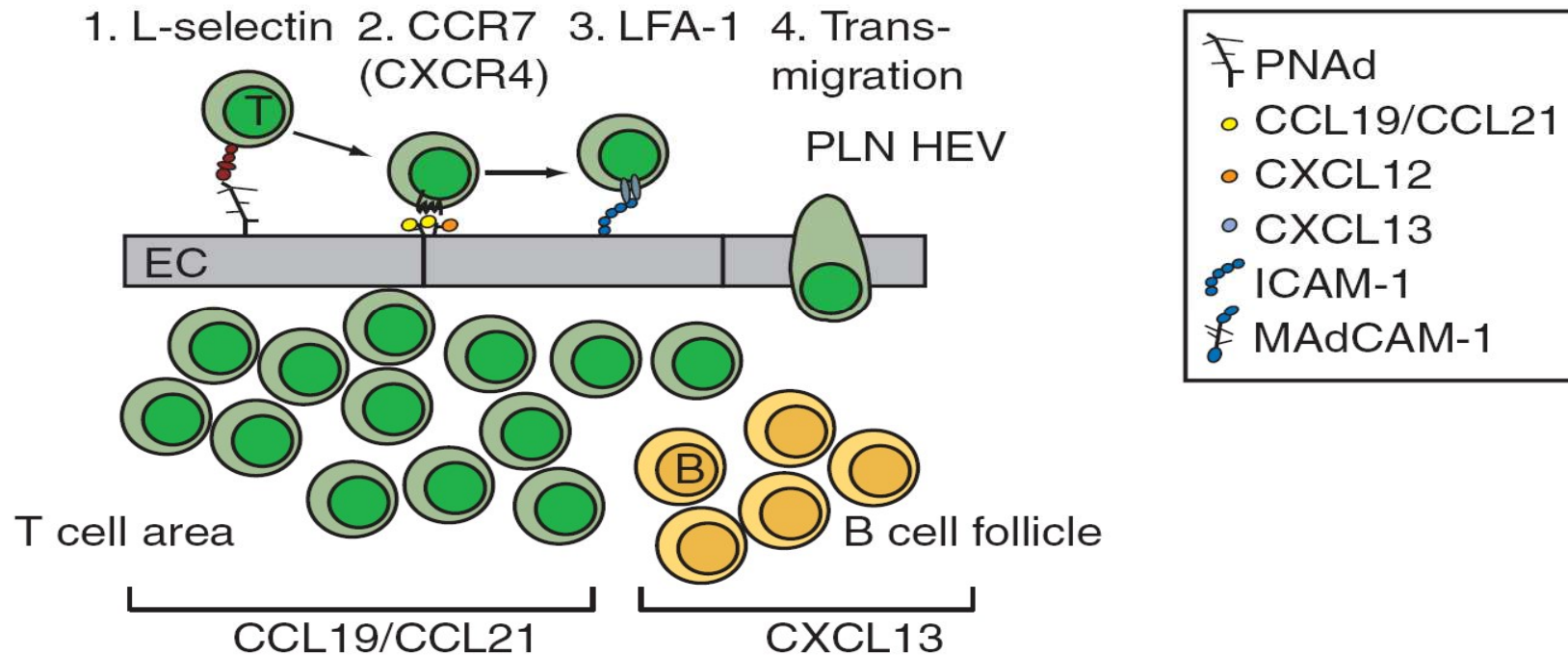

Figure 10-7 Immunobiology, 6/e. (© Garland Science 2005)

Chemokines and lymphocyte homing in secondary lymphoid organs

(a)



(B)

T cell zone
(parafollicular
cortex)

B cell zone
(lymphoid
follicle)

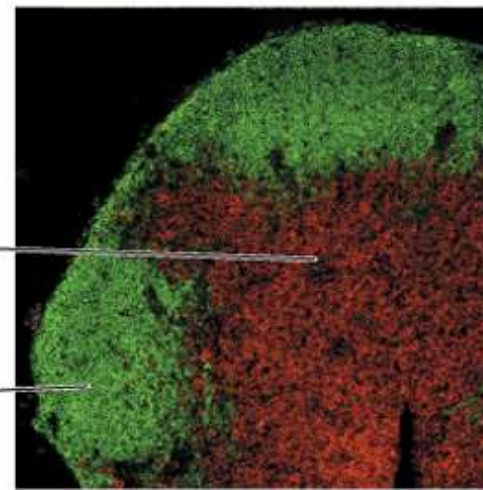

Perchè le cellule T non entrano nella regione sottocapsulare del linfonodo?

MICROSCOPIA INTRAVITALE

Microscopia intravitale:

- microscopia confocale
- microscopia a due o più fotoni

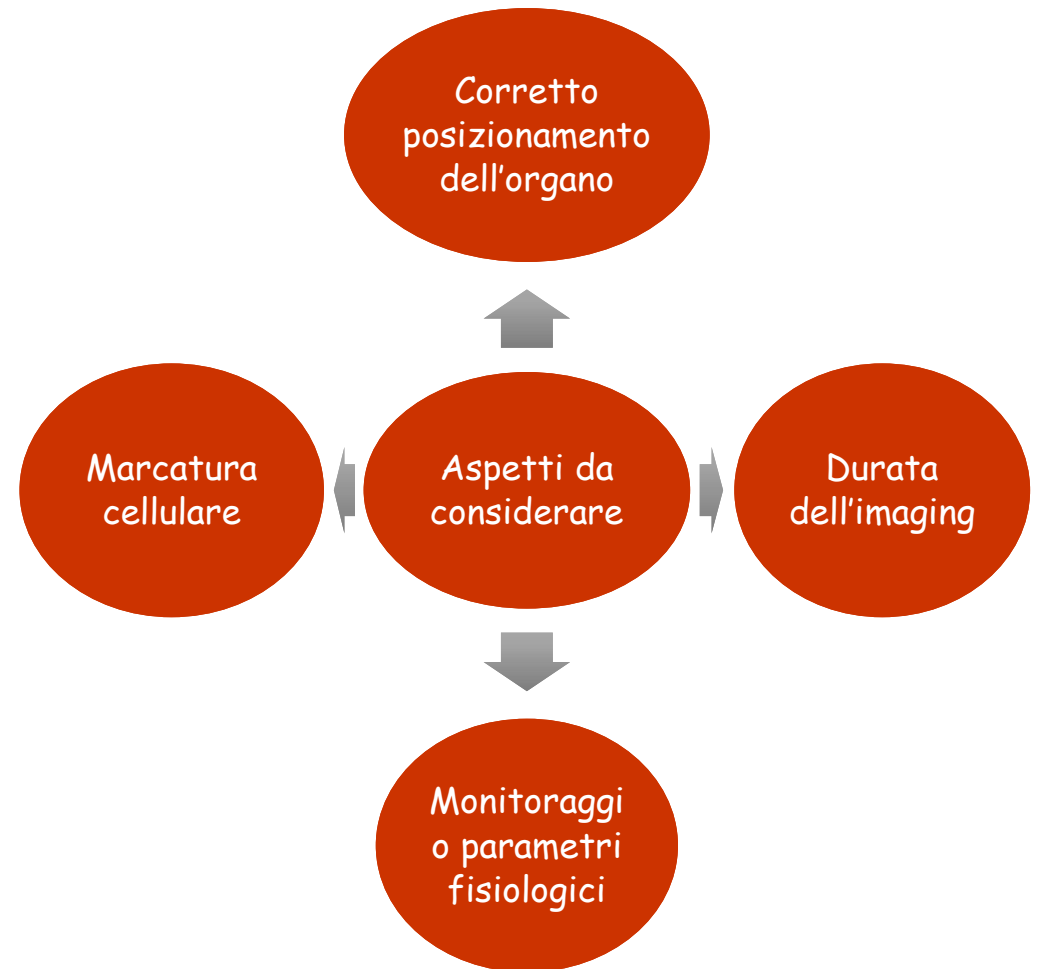
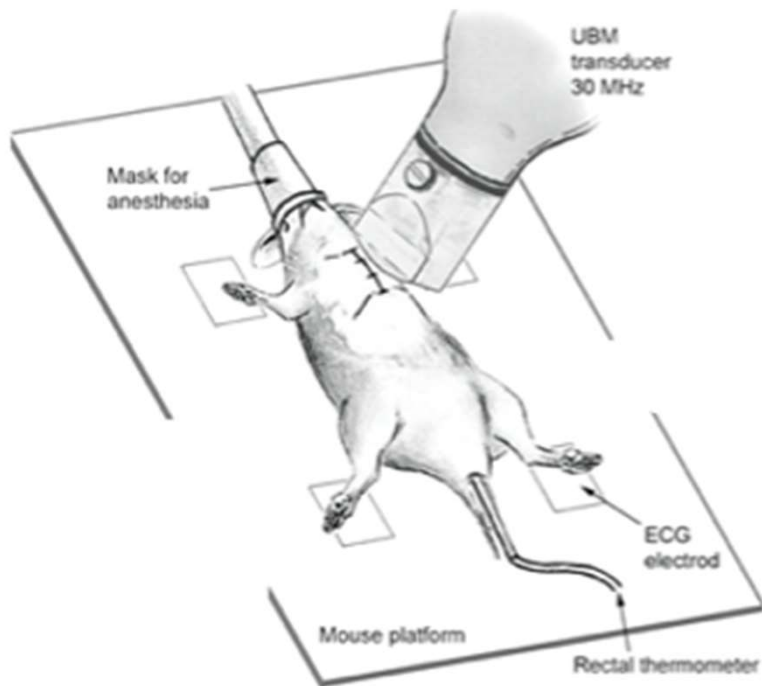

MICROSCOPIA INTRAVITALE

I ligandi di *CCR7* stimolano la motilità dei linfociti T dentro ai linfonodi in vivo ma non sono presenti nella regione sottocapsulare

Cosa succede se iniettiamo i ligandi di *CCR7* nella regione sottocapsulare?

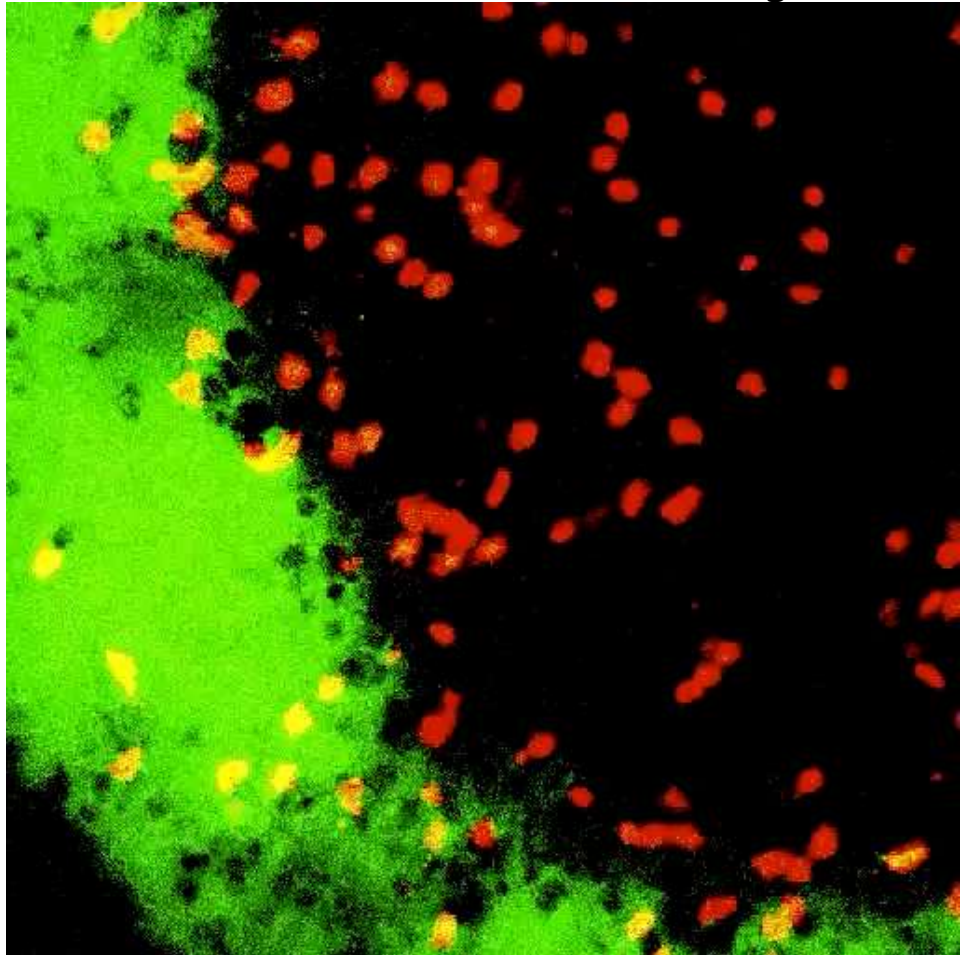

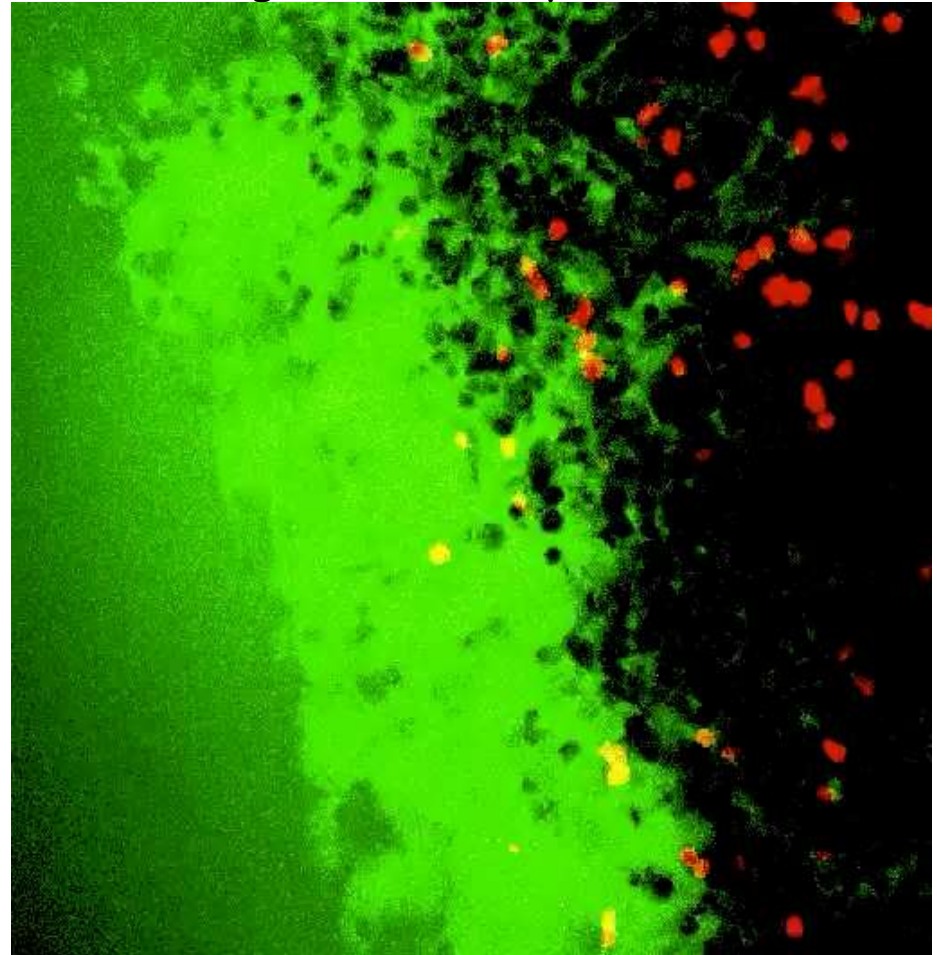

CCR7+



CCR7-deficient

High endothelial venules have peculiar characteristics

	Normal venule	Peripheral lymph-node HEV	Peyer's-patch HEV
			
Endothelium	Flat	Tall and plump	Tall and plump
Basal lamina	Thin	Thick	Thick
Perivascular sheath	Scanty	Prominent	Prominent
CD31	+	+	+
ICAM2	+	+	+
ICAM1	-/+	++	++
VE-cadherin	+	+	+
Sialomucins			
Core protein	+	++	+
PNAD epitope	-	++	+
Sulphation	-	+	+
MADCAM1	-	-	+
Chemokines (CCL19, CCL21, CXCL12 and CXCL13)	-	+	+

Lymphoid organ exit is a mechanisms controlled by sphingosine-1-phosphate

Should I stay or should I go?.....

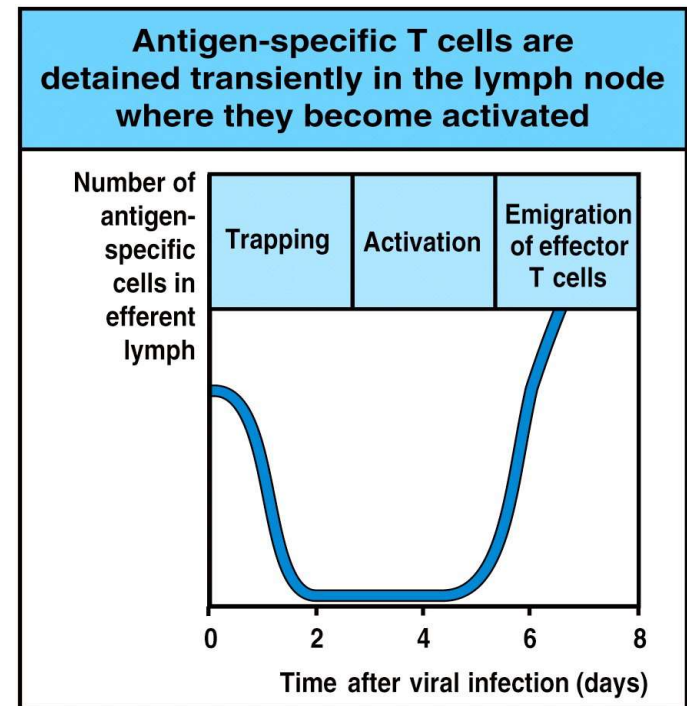
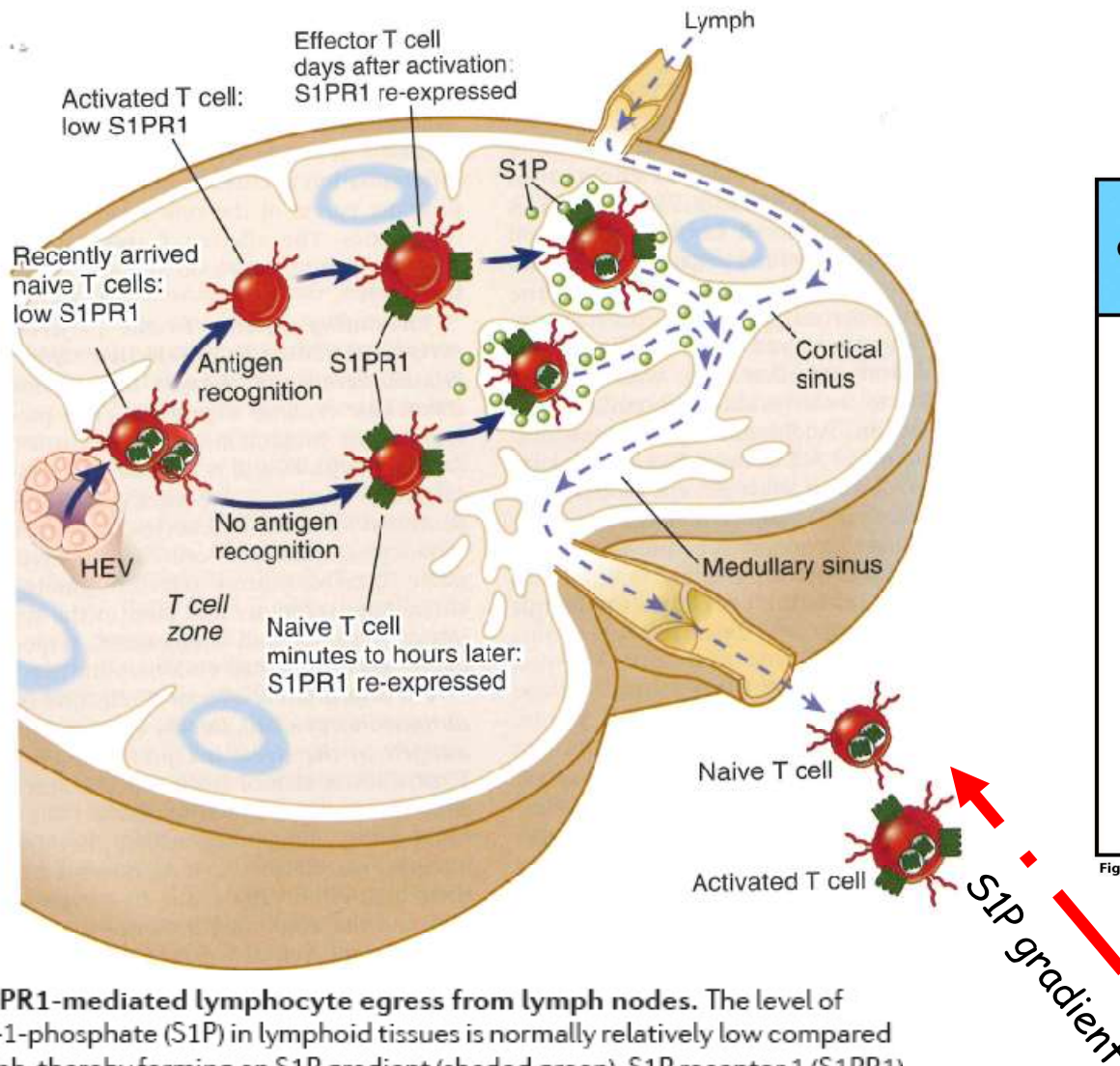

Figure 10-8 Immunobiology, 6/e. (© Garland Science 2005)

Figure 3 | S1PR1-mediated lymphocyte egress from lymph nodes. The level of sphingosine-1-phosphate (S1P) in lymphoid tissues is normally relatively low compared with the lymph, thereby forming an S1P gradient (shaded green). S1P receptor 1 (S1PR1) expressed on T cells is responsive to the S1P gradient and promotes T-cell egress from the lymphoid organ through the endothelial barrier into lymph. After activation of the T cell in the lymphoid organ by encountering an antigen-expressing dendritic cell or by type I interferon stimulation, S1PR1 expression is decreased. Mechanisms include

Homing costitutivo

Tropismo per organi linfoidi secondari (linfonodi, Placche di Peyer, milza) da parte di linfociti T e B "vergini".

What happens following T cell activation?

Homing inducibile e tessuto specifico

La stimolazione antigenica “riprogramma” le proprietà di traffico di cellule B e T “vergini” inducendo il differenziamento di **cellule effettrici e **memoria** che**

a- hanno migliori capacità di homing per tessuti extralinfoidi rispetto alle vergini

b- sono in grado di “SELEZIONARE” tessuti e organi specifici dove dirigersi ritornando preferenzialmente nel tessuto che ne ha causato l’attivazione (cioè dove è più probabile trovare l’antigene che li ha attivati).

Homing inducibile e tessuto specifico

La stimolazione antigenica “riprogramma” le proprietà di traffico di cellule B e T “vergini” inducendo il differenziamento di **cellule effettrici** e **memoria** che

a- hanno migliori capacità di homing per tessuti extralinfoidi rispetto alle vergini

b- sono in grado di “SELEZIONARE” tessuti e organi specifici dove dirigersi ritornando preferenzialmente nel tessuto che ne ha causato l’attivazione (cioè dove è più probabile trovare l’antigene che li ha attivati).

I linfociti T attivati cambiano l'espressione di superficie di diverse molecole







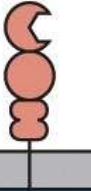

		Cell-surface molecules									
											
CD4 T cell		L-selectin	S1P ₁	CD45RA	CD45RO	VLA-4	CD4	T-cell receptor	LFA-1	CD2	CD44
Resting		+	+	+	-	-	+	+	+	+	+
Activated		-	-	-	+	+	+	+	++	++	++

Figure 9.25 Janeway's Immunobiology, 8ed. (© Garland Science 2012)

Promotes homing to lymph nodes
 Promotes exit from lymph nodes

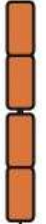
Promotes homing to inflamed tissues

Anche il recettore CCR7 è fortemente down-modulato a seguito dell'attivazione (viene mantenuto solo da una piccola popolazione che continua a ricircolare nei linfonodi)

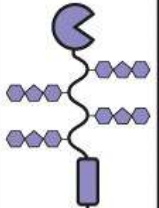
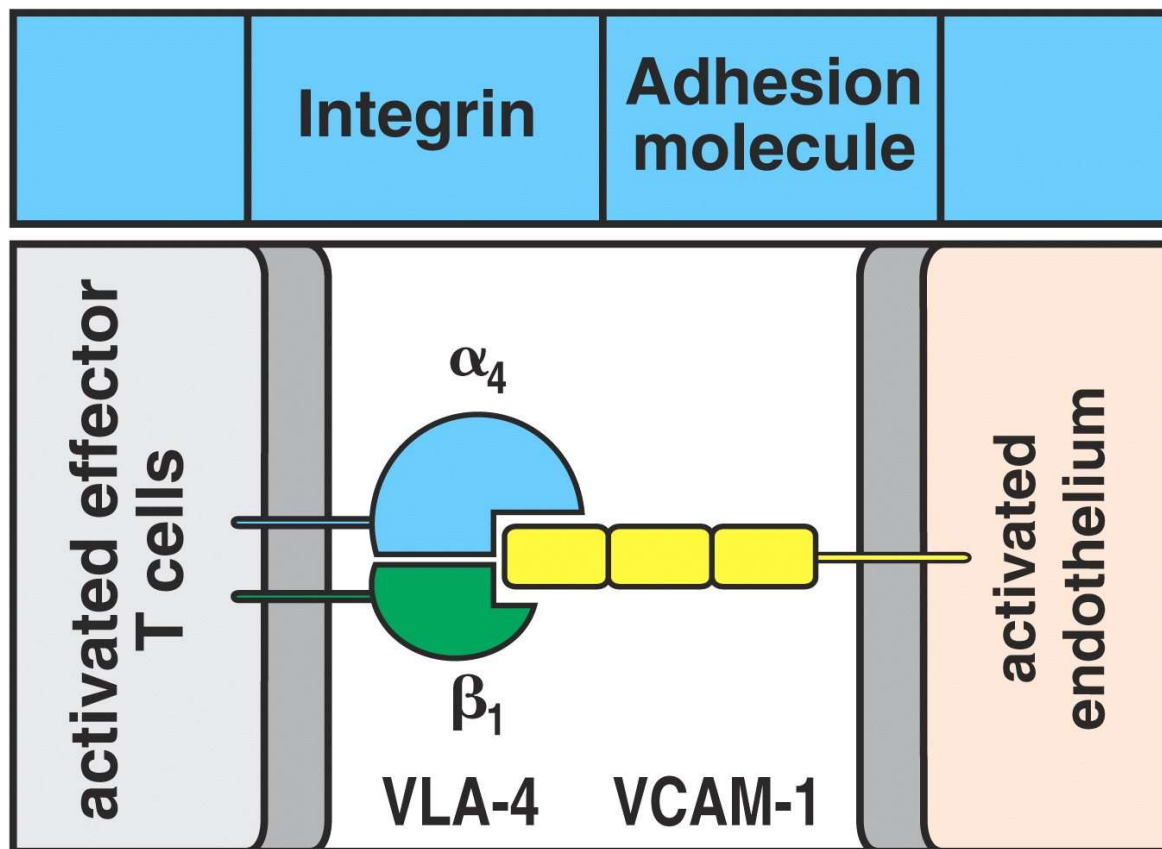
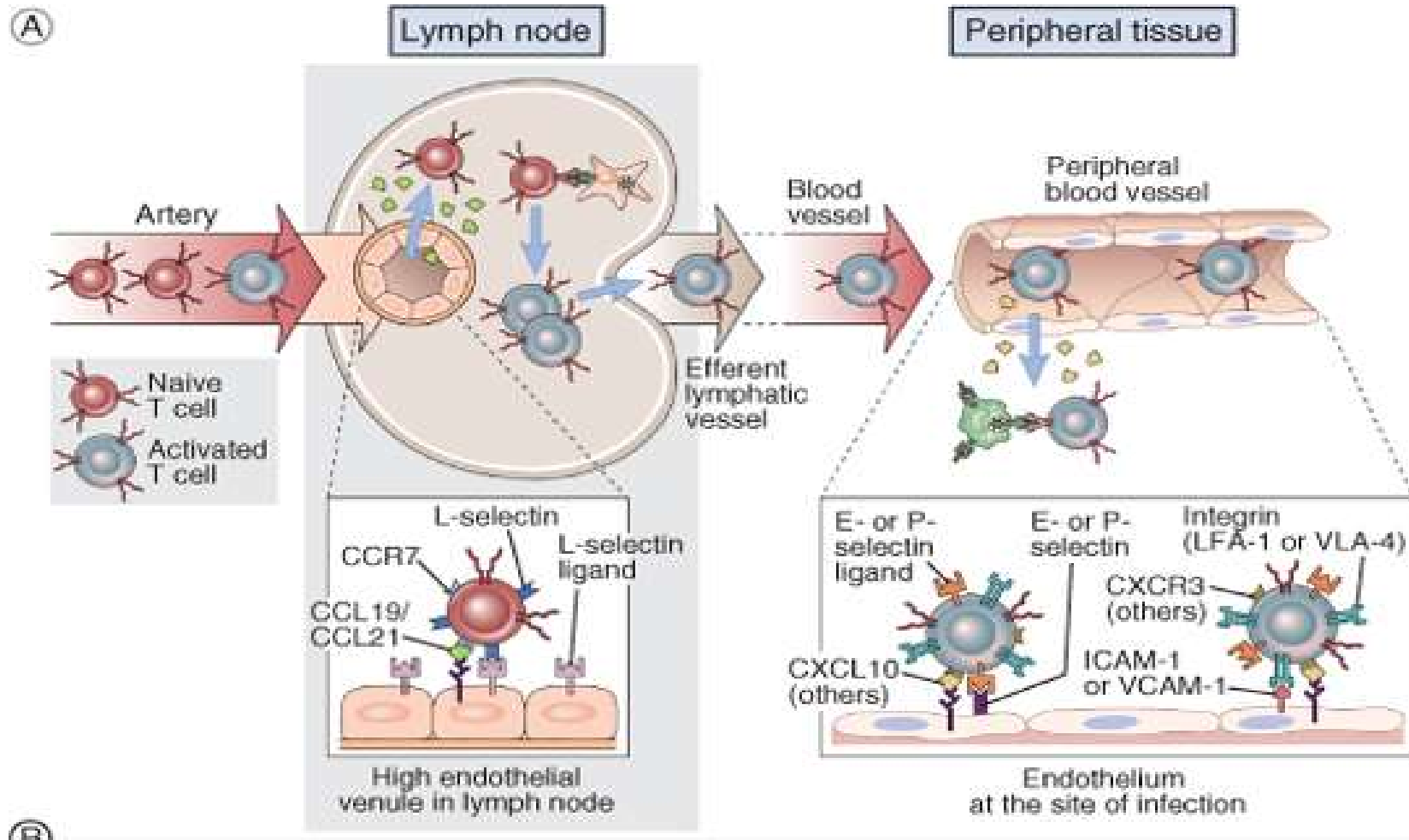

Figure 8-6 part 3 of 3 Immunobiology, 6/e. (© Garland Science 2005)

Il membro più importante della sottofamiglia delle integrine beta-1 sui leucociti è **Very Late Antigen-4, VLA-4**. VLA-4 lega il suo ligando **Vascular Cell Adhesion Molecule- 1, VCAM-1** ed è primariamente responsabile dell'adesione linfocitaria all'endotelio vascolare e del loro richiamo nei tessuti.

Migrazione di linfociti T vergini e attivati



I linfociti effettori migrano nei focolai infettivi..

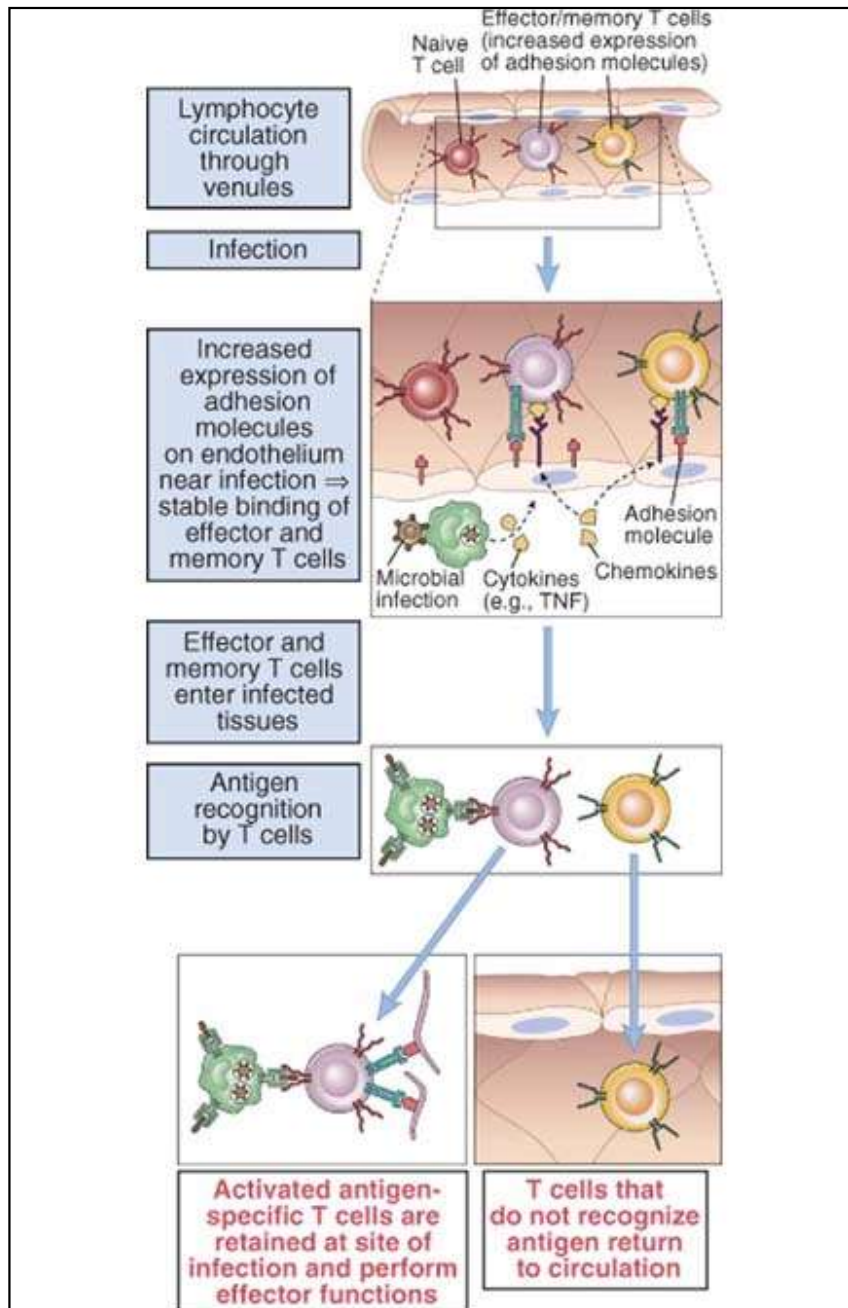

B)

T cell homing receptor	Ligand on endothelial cell	Function of receptor: ligand pair
Naive T cells L-selectin CCR7	L-selectin ligand CCL19 or CCL21	Adhesion of naive T cells to high endothelial venule in lymph node
Activated (effector and memory) T cells E- and P-selectin ligand LFA-1 ($\beta 2$ -integrin) or VLA-4 ($\beta 1$ integrin) CXCR3 CCR5	E- or P-selectin ICAM-1 or VCAM-1 CXCL10 (others) CCL4 (others)	Initial weak adhesion of effector and memory T cells to cytokine activated endothelium at peripheral site of infection Stable arrest on cytokine activated endothelium at peripheral site of infection Activation of integrins and chemokinesis Activation of integrins and chemokinesis

© Elsevier. Abbas et al: Cellular and Molecular Immunology 6e - www.studentconsult.com

Homing tessuto specifico

La stimolazione antigenica “riprogramma” le proprietà di traffico di cellule B e T “vergini” inducendo il differenziamento di cellule effettrici e memoria che

a- hanno migliori capacità di homing per tessuti extralinfoidi rispetto alle vergini

b- sono in grado di “SELEZIONARE” tessuti e organi specifici dove dirigersi ritornando preferenzialmente nel tessuto che ne ha causato l’attivazione (cioè dove è più probabile trovare l’antigene che li ha attivati).

Generazione di popolazioni T effettrici con preferenziale tropismo verso tessuti extra-linfoidi

T cell activation

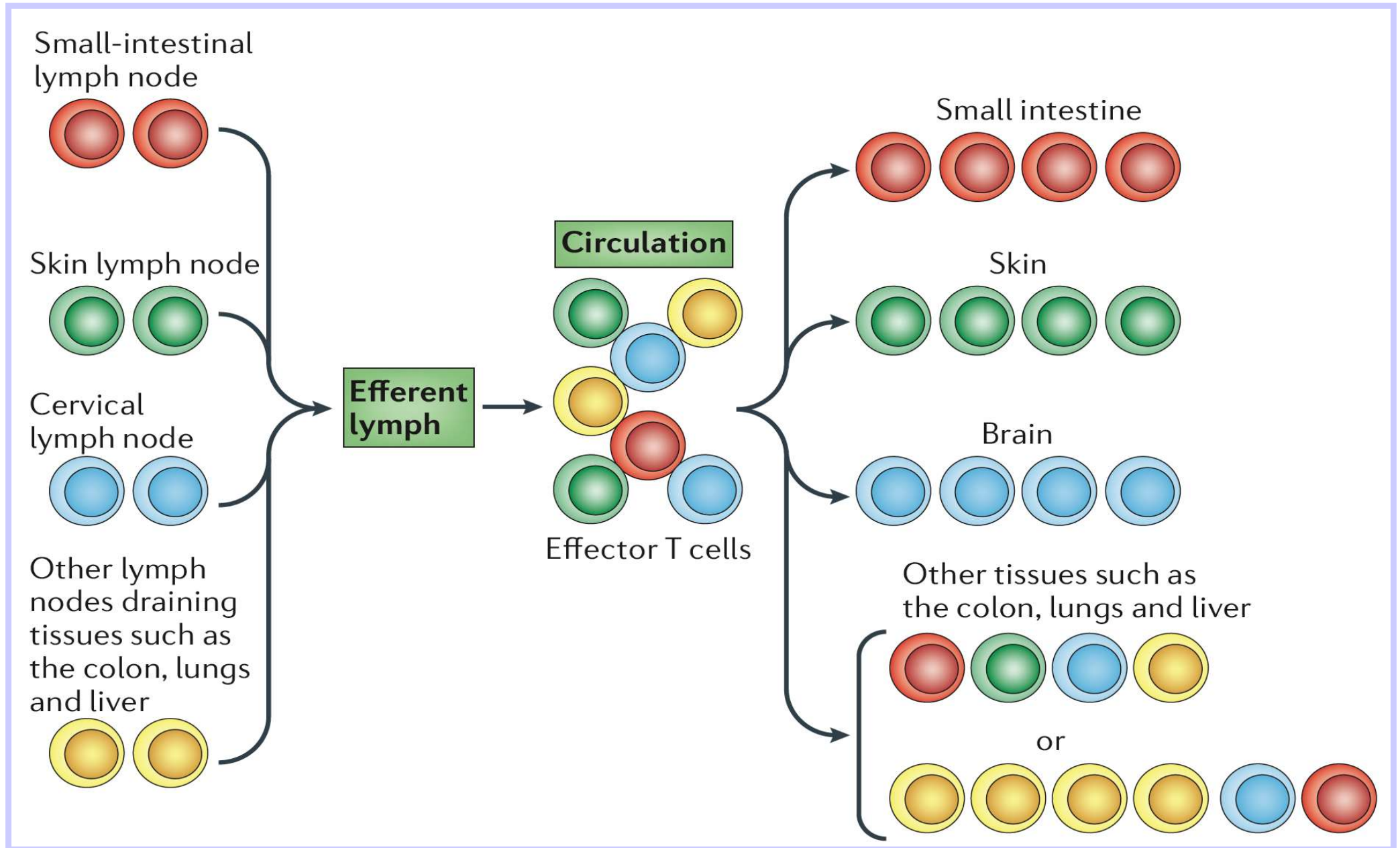

Un differente set di molecole di adesione e di chemochine guida la migrazione tessuto specifica

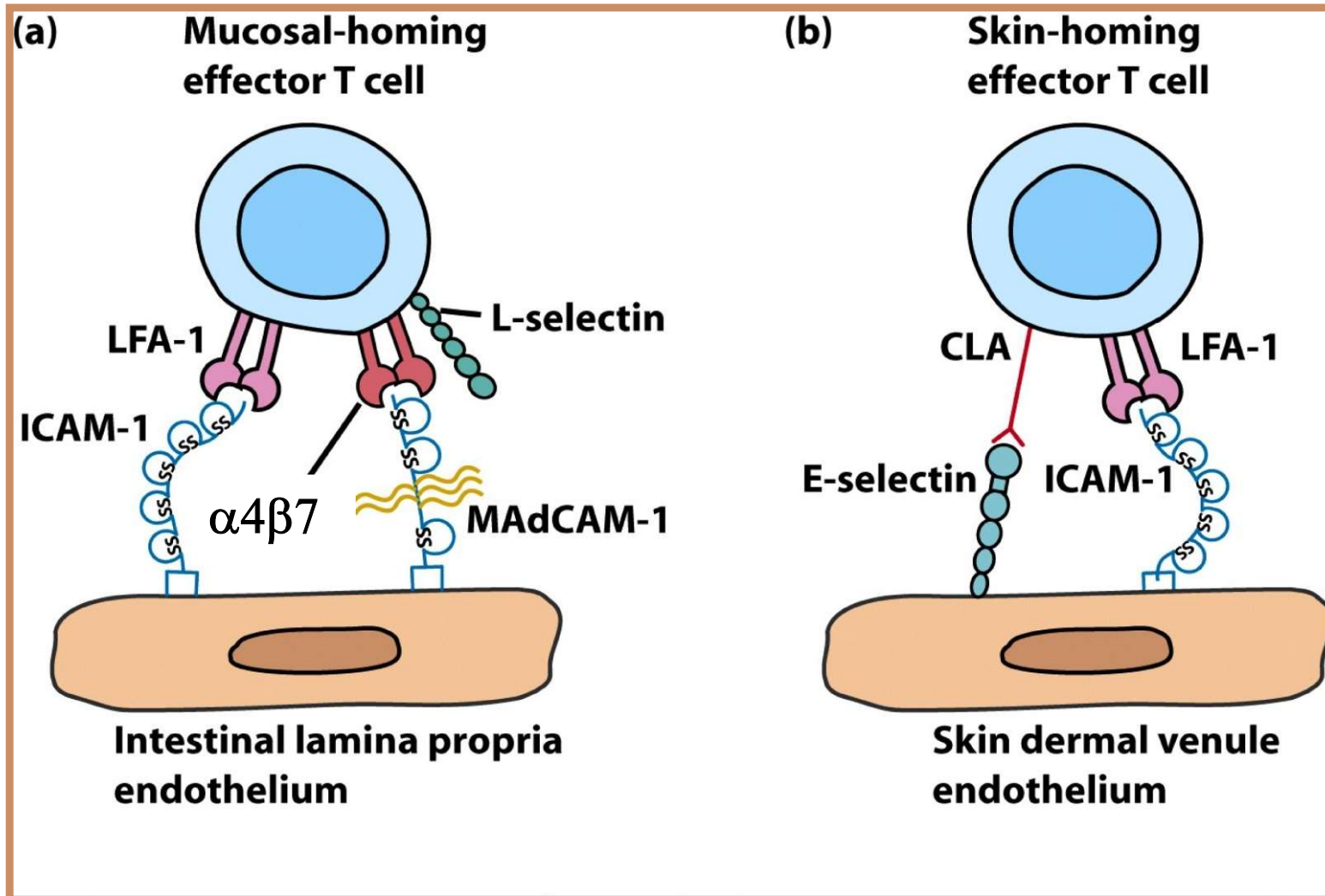

CLA=cutaneous lymphocyte antigen

Tissue specific lymphocyte homing is regulated by chemokines

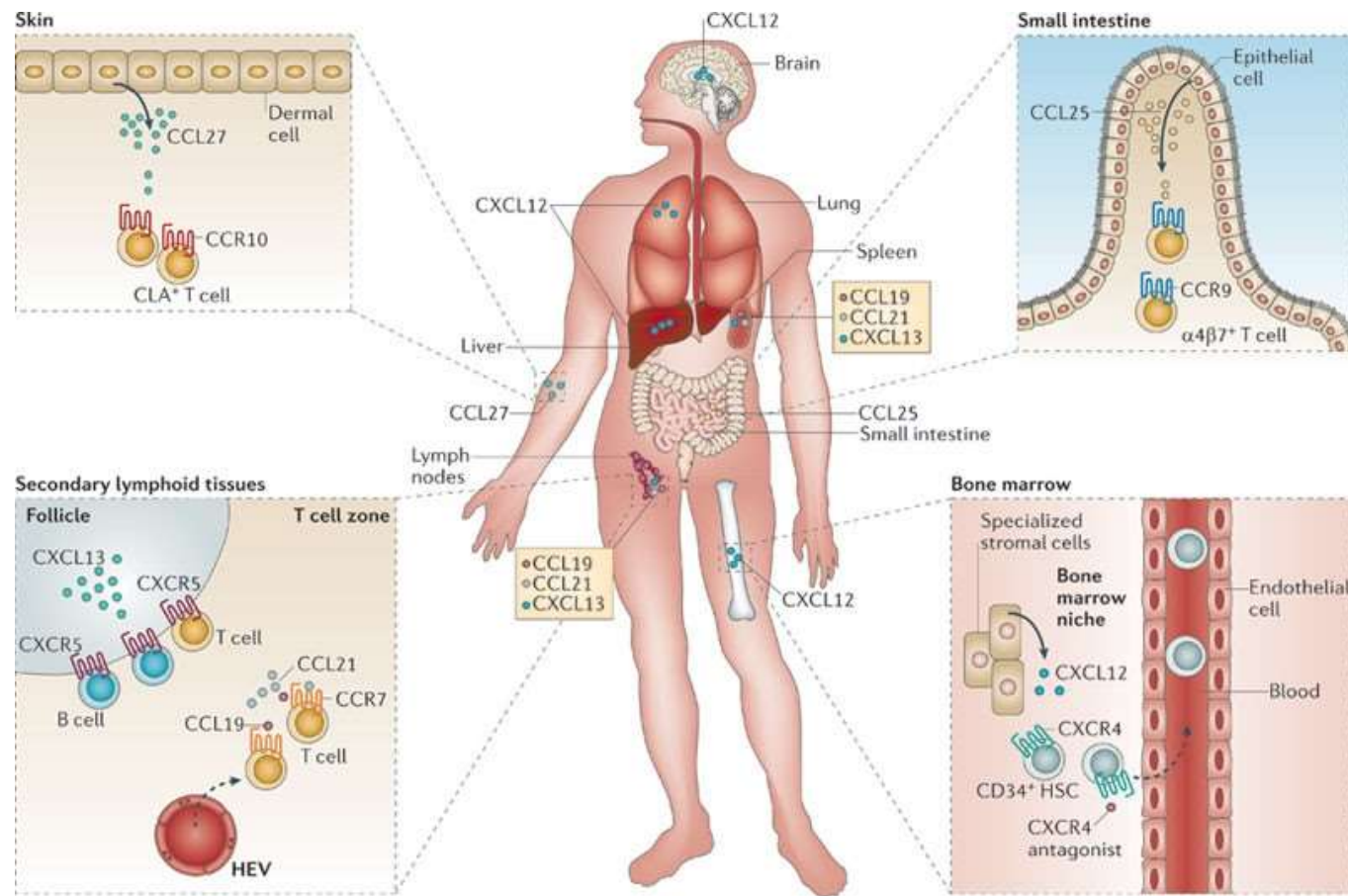

Nature Reviews | Immunology

Chemokine expression marks exit points of cellular highways for T lymphocyte populations expressing their specific receptor

These cellular highways can also be used by cancer cells during metastasis

Zlotnik Nat rev Immunol 2011

Signals guiding the migration of activated T cells to cutaneous sites

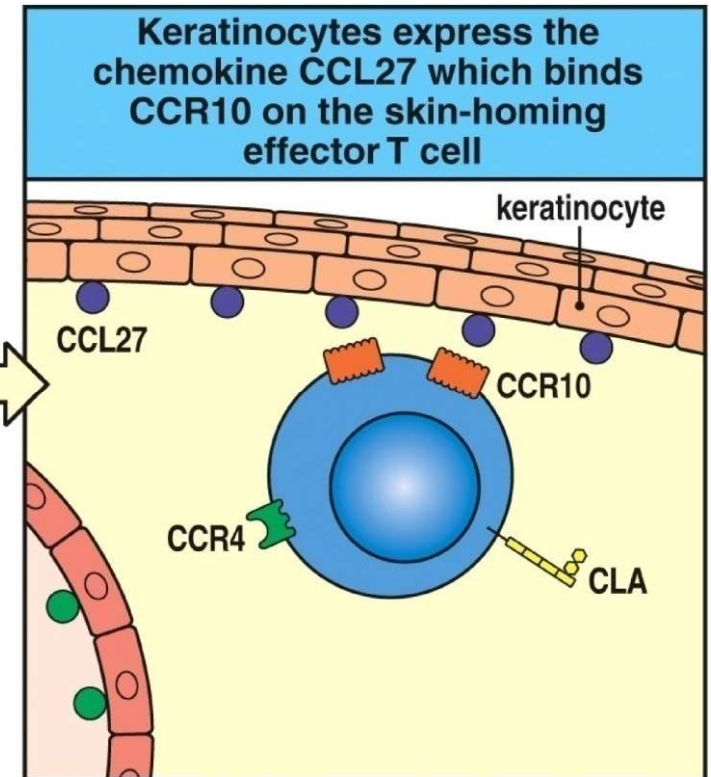
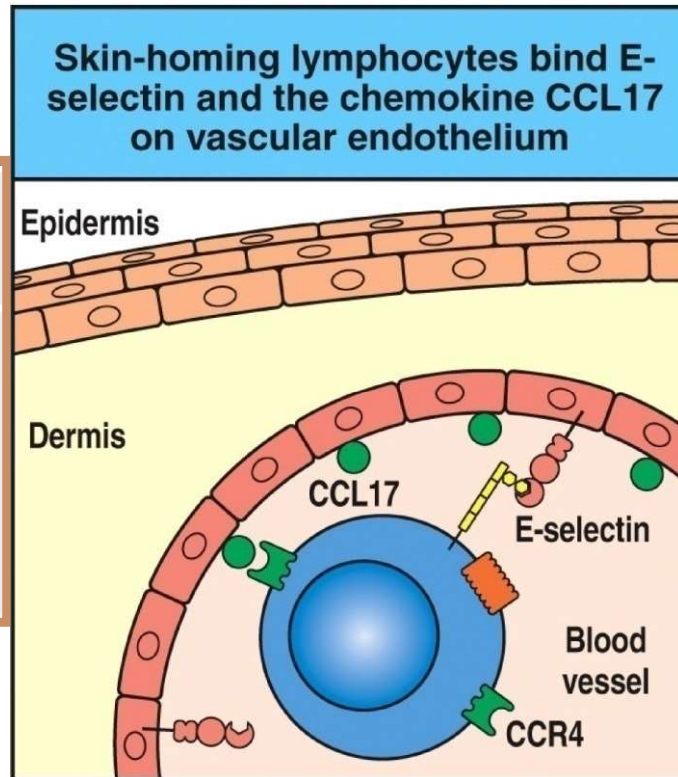
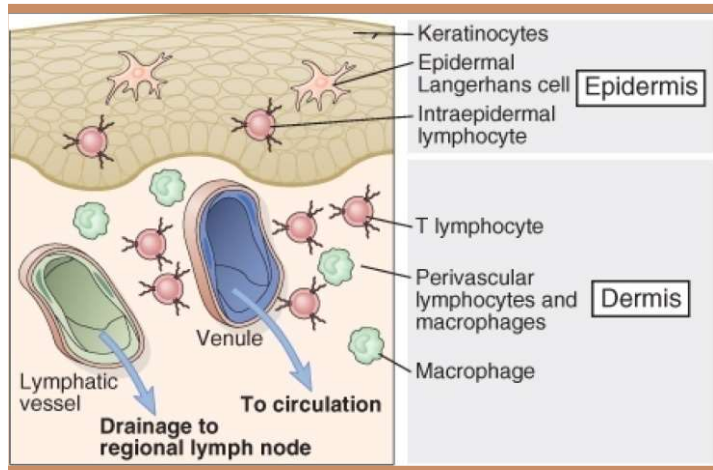

Signals guiding the migration of activated T cells to mucosal sites

mucosal sites

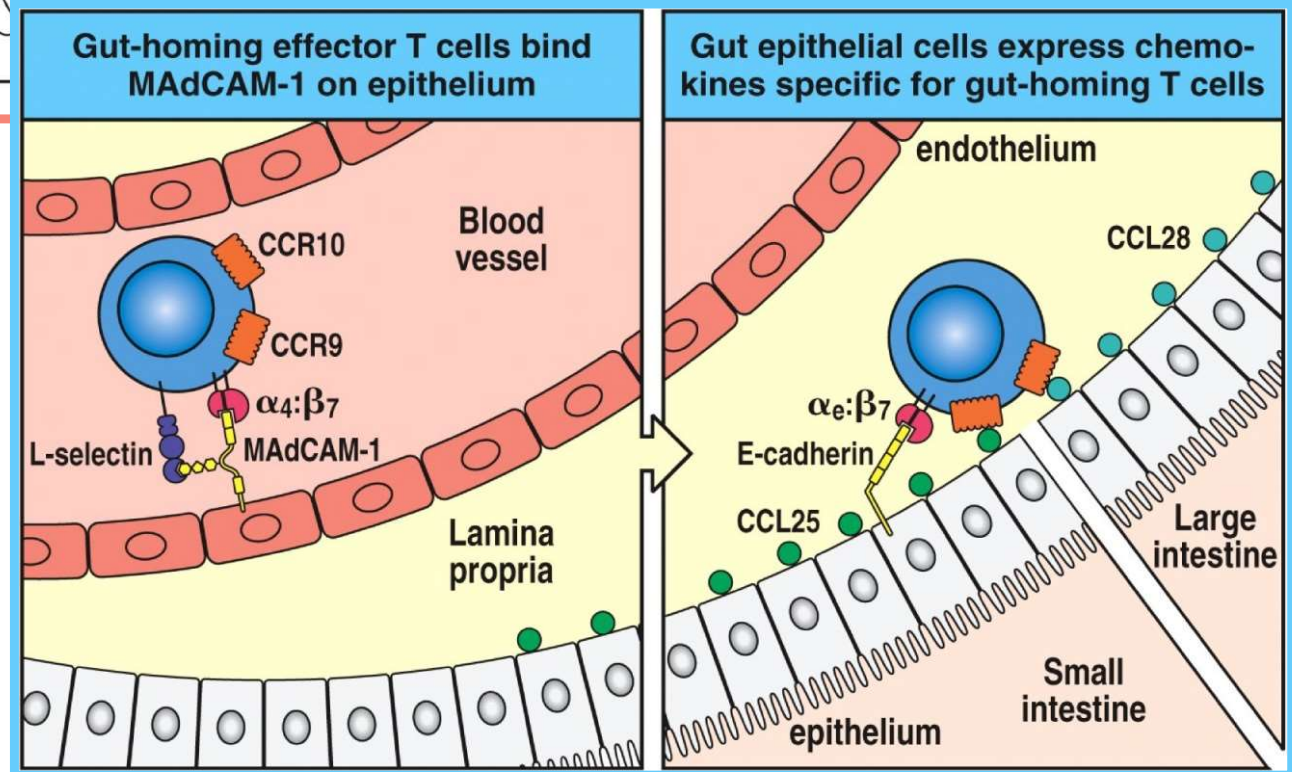
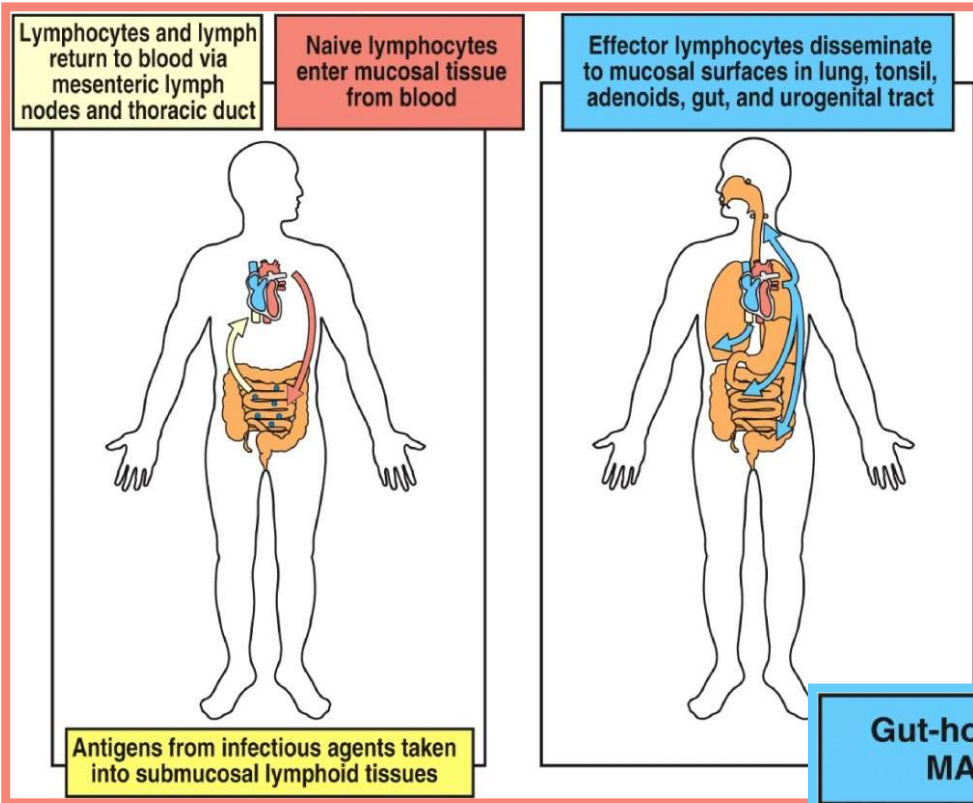

Le chemochine svolgono un ruolo chiave sia nell'homing costitutivo che nell'homing tessuto-specifico delle popolazioni linfocitarie

CCL19, CCL21 sono ligandi del CCR7, recettore di Homing nei linfonodi per i linfociti T vergini

CXCL-13 lega CXCR5, recettore di homing per linfociti B nei linfonodi. CXCR4.....

TARC (CCL17) e CTACK (CCL27) legano CCR4 e CCR10 rispettivamente, recettori di Homing per la cute

TECK (CCL25) lega CCR9 che "direziona" i linfociti nelle mucose

B lymphocyte migration (role of chemokines)

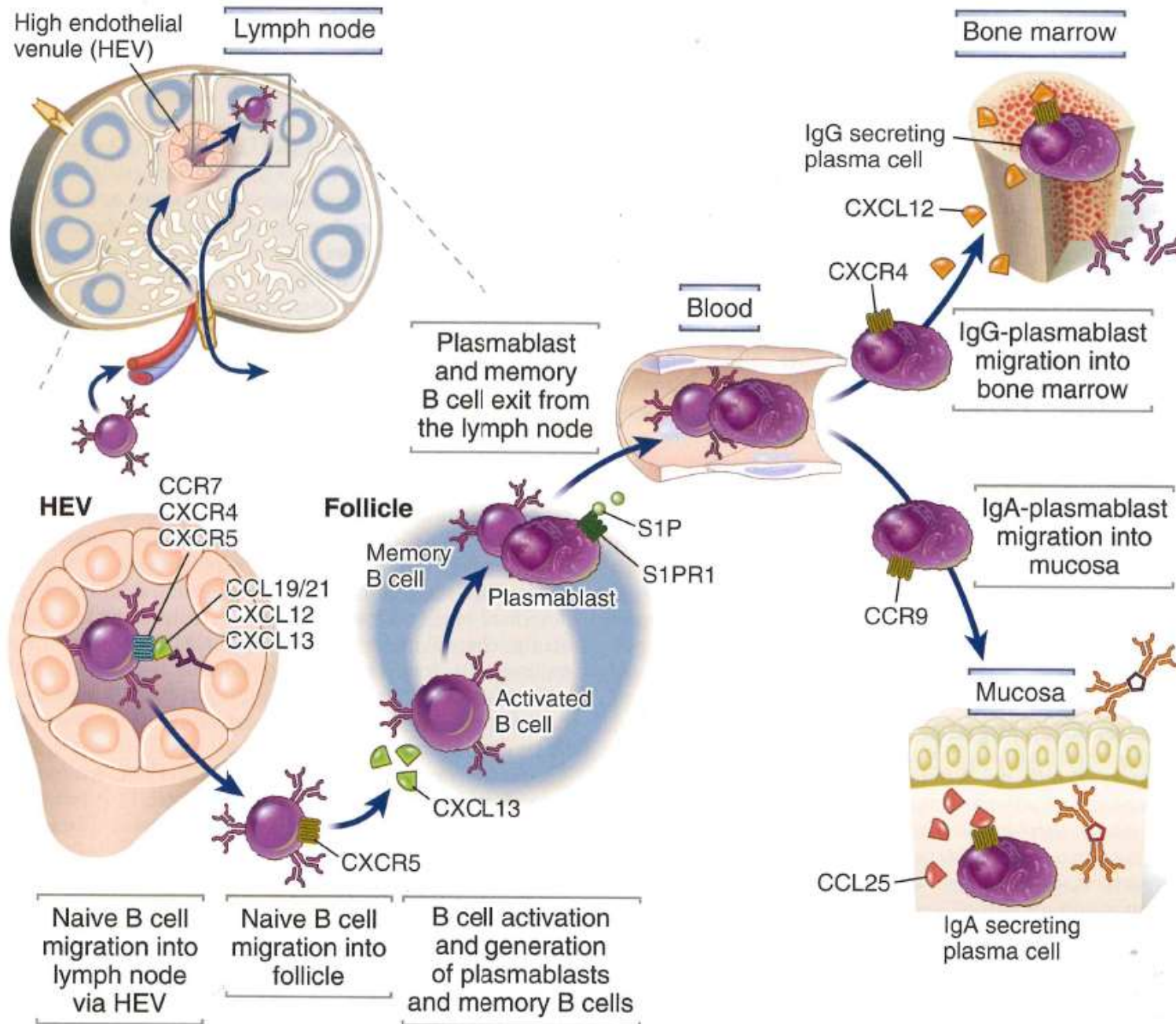

Alterazioni congenite della funzione leucocitaria

• Difetti di adesione

LAD-1: Espressione assente o deficitaria delle integrine beta-2 (LFA-1, Mac-1) con conseguente deficit delle funzioni leucocitarie (infezioni ricorrenti da batteri e miceti)
(mutazione del gene che codifica per beta-2 o , in alcune varianti, mancata espressione di molecole coinvolte nell'attivazione delle beta-2)

LAD-2 Espressione deficitaria di ligandi per E- e P- Selectine
(mutazione nel gene che codifica per la fucosil-transferasi)

LAD-3 Difetto nelle vie di segnalazione che portano all'attivazione di integrine beta-2

WHIM syndrome is an inherited immunodeficiency caused by overactivity of CXCR4, a receptor controlling production and distribution of leukocytes in bone marrow and blood.

The term "WHIM" is an acronym for the main manifestations of the disease: **W**arts, **H**ypogammaglobulinemia, recurrent **I**nfections, and **M**yelokathexis;

myelokathexis refers to impaired egress of mature neutrophils from bone marrow causing neutropenia

Utilizzo di antagonisti e anticorpi bloccanti diretti contro alfa4 integrine in modelli di infiammazione cronica e autoimmunita'

Natalizumab e' un anticorpo umanizzato che blocca la funzione dell'integrina alfa4

Derivati del peptide LDV che si lega all'integrina nella sua conformazione ad alta affinita' bloccandone la funzione

E' in corso di valutazione in trial clinici che coinvolgono pazienti Affetti da Morbo di Chron, colite ulcerosa e Sclerosi Multipla

